

## T3M Vehicle

# WorkShop Manual & Spare Parts Catalog



## Taurus Vehicle – Guideline and spare parts book

Written by:

Verified by:

Approved by:

Approved by:

A	08/2024	Creation	GD - CC		
Rev.	Date	Subject	Written by	Approved by	Approved by
REVISION LOG					

# TABLE OF CONTENT T3M Vehicle – GD



## 1 Vehicle Overview

- 1.1.1 VEHICLE OVERVIEW – Size – Left and Right
- 1.1.2 VEHICLE OVERVIEW – Size – Front and Back
- 1.1.3 VEHICLE OVERVIEW – Size – Top and Bottom
- 1.2 VEHICLE OVERVIEW – Transportation

## 2 Chassis

- 2.1 CHASSIS – Overview
- 2.2 CHASSIS – Preparation
- 2.3.1 CHASSIS – Rear wall
- 2.3.2 CHASSIS – Air Vein Composite – Top
- 2.3.3 CHASSIS – Window Net
- 2.3.4 CHASSIS – Exterior Walls – Composite
- 2.3.5 CHASSIS – Exterior Walls – Shaft guard

## 3 Rigid lines

- 3.1 RIGIDE LINES – Braking circuit
- 3.2 RIGIDE LINES– Clutch – Circuit
- 3.3 RIGIDE LINES – Brakes and Clutch Hoses Detail Pictures
- 3.4 RIGIDE LINES – Fire Extinguisher Kit – Circuit details
- 3.5 PEDALBOX

## 4 Fuel cell

- 4.1 FUEL STORAGE – Aluminum Fuel Tank
- 4.2 FUEL STORAGE – Aluminum Fuel Tank Pressure Relief
- 4.3 FUEL STORAGE – Composite Fuel Tank
- 4.4 FUEL STORAGE – Composite Fuel Tank Pressure Relief
- 4.5 FUEL STORAGE – Fuel Filling
- 4.6 FUEL STORAGE – Fuel Supply

## 5 Powertrain

- 5.1 POWERTRAIN – Overview
- 5.2 POWERTRAIN – Engine – Pre-Assembly
- 5.3 POWERTRAIN – Preparation
- 5.4 POWERTRAIN – Engine – Accessories
- 5.5 POWERTRAIN – Engine – Sensors
- 5.6 POWERTRAIN – Engine Plugs and Sealing
- 5.7 POWERTRAIN – Intake line adapter
- 5.8 POWERTRAIN – Flywheel
- 5.9 POWERTRAIN – Clutch
- 5.10 POWERTRAIN – Loom set-up
- 5.11 POWERTRAIN – Gearbox
- 5.12 POWERTRAIN – Clutch, Hose and sealing
- 5.13 POWERTRAIN – Clutch Housing
- 5.14 POWERTRAIN – Gear box fixing to chassis
- 5.15 POWERTRAIN – Engine – Gearbox assembly
- 5.16 POWERTRAIN – Engine support cross member
- 5.17 POWERTRAIN – Inspection Hatch
- 5.18 POWERTRAIN – Gearbox cooler
- 5.19 POWERTRAIN – Engine Starter
- 5.20 POWERTRAIN – Decanter
- 5.21 POWERTRAIN – Exhaust line
- 5.22 POWERTRAIN – Tools / Spare parts

## 6 Cooling system

- 6.1 COOLING – Air Vein Composite – Rear overview
- 6.2 COOLING – Air Vein Composite – Rear Details
- 6.3 COOLING – Overview
- 6.4 COOLING – Air / Water
- 6.5 COOLING – Air / Air

# TABLE OF CONTENT T3M Vehicle

## 7 Intake line

- 7.1 INTAKE LINE – Turbo Charger – Plugs
- 7.2 INTAKE LINE – Turbo Charger – Nturbo
- 7.3 INTAKE LINE – Turbo Charger – FIA Restrictor
- 7.4 INTAKE LINE – Turbo Charger – Locking wire
- 7.5 INTAKE LINE – Turbo Charger – Fixing to motor
- 7.6 INTAKE – Turbocharger – Heatshield
- 7.7 INTAKE LINE – Air cardrige/Filter
- 7.8 INTAKE LINE – Intake Pipe

## 8 Front and rear drive

- 8.1 FRONT AND REAR DRIVE – Overview
- 8.2 Wishbone protocol assembly – Upper / lower – Front / Rear
- 8.3 Lower wishbone – Front right, Rear Left.
- 8.4 Upper WISHBONE – Left & Right, Front & Rear
- 8.5 Front drive – ASSEMBLY WHEEL HUB CARRIER RIGHT + LEFT
- 8.6 ROD EQUIPPED RIGHT + LEFT

## 9 Suspension

### 10 Drive Train

- 10.1 DRIVETRAIN – Overview
- 10.2 DRIVETRAIN – Front Differential
- 10.3 DRIVETRAIN – Wheel Shaft
- 10.4 DRIVETRAIN – Front Drive Shaft Guard 10.5 SEATBENCH
- 10.6 DRIVETRAIN – Front and Rear Drive Shaft
- 10.7 REAR DIFFERENTIAL

### 11 Brakes

- 11.1 BRAKES – Overview
- 11.2 BRAKES – Disc
- 11.3 BRAKES – Calipers – Front Right & Left
- 11.4 BRAKES – Braking circuit

## 12 Steering

- 12.1 STEERING – Overview
- 12.2 STEERING – Rack Steering
- 12.3 STEERING – Column
- 12.4 STEERING – Unit Power Steering
- 12.5 STEERING – Steering Wheel

## 13 Cockpit

- 13 COCKPIT – Overview
- 13.1 COCKPIT – Fire Extinguishers
- 13.2 COCKPIT – Pedal box
- 13.3 COCKPIT – Floor Footrest
- 13.4 COCKPIT – Gear Shift
- 13.5 COCKPIT – Safety Belts
- 13.6 COCKPIT – SEAT
- 13.7 COCKPIT – Blower
- 13.8.1 INTERIOR TRIM – Partition undear seat – Aluminium Tank
- 13.8.2 INTERIOR TRIM – Partition undear seat –Composite Tank
- 13.8.3 INTERIOR TRIM – Dashboard
- 13.7 COCKPIT – Extinguisher

## 14 Body

- 14.1 BODY – Hood – Chassis preparation – Without Windshield
- 14.2 BODY – Hood – Chassis preparation – With windshield
- 14.3 BODY – Front Car Side
- 14.4 BODY – Roof – Without Windshield
- 14.5 BODY – Roof – With Windshield
- 14.6 BODY – Rear Car Side
- 14.7 BODY – Car Tailgate – Overview
- 14.8 BODY – Spoiler – Overview
- 14.9 BODY – Rear Wings Bracket Right & Left
- 14.10 BODY – Doors
- 14.11 BODY – Hood – Without Windshield
- 14.12 BODY – Hood – With windshield
- 14.13 BODY – Wipers
- 14.14 BODY – Windshield
- 14.15 BODY – Spare wheels holder L and R

# TABLE OF CONTENT T3M Vehicle

---

## 15 Exterior trim

- 15.1 EXTERIOR TRIM – Ski – Overview
- 15.2 EXTERIOR TRIM – Ski – Front Ski
- 15.3 EXTERIOR TRIM – Ski – Fuel Tank Ski
- 15.4 EXTERIOR TRIM – Ski – Central Front Ski
- 15.5 EXTERIOR TRIM – Ski – Rear Ski
- 15.6 EXTERIOR TRIM – Ski – Rear Soft Flap
- 15.7 EXTERIOR TRIM – Rear View Mirrors

## 16 Accessories

- 16.1 ACCESSORIES – Drinking Water
- 16.2 ACCESSORIES – Engine oil and brake fluid
- 16.3 ACCESSORIES – Sand Plate Holder
- 16.4 ACCESSORIES – Towing
- 16.5 ACCESSORIES – Refuel Hose, Refuel Vent Hose, Fuel Drain Hose

## 17 Electrical components

- 17.1 ELECTRICAL COMPONENTS – Power Unit Main power circuit
- 17.2 ELECTRICAL COMPONENTS – Battery 12V
- 17.3. ELECTRICAL COMPONENTS – Management System
- 17.4 ELECTRICAL COMPONENTS – Front loom EV1
- 17.5 ELECTRICAL COMPONENTS – Rear loom
- 17.6 ELECTRICAL COMPONENTS – Front loom EV2
- 17.7 ELECTRICAL COMPONENTS – Rear loom EV2
- 17.8 ELECTRICAL COMPONENTS – Dashboard PMU16
- 17.9 ELECTRICAL COMPONENTS – Dashboard HP8442
- 17.10 ELECTRICAL COMPONENTS – Lighting
- 17.11 ELECTRICAL COMPONENTS – Navigation System – Marlink
- 17.12 ELECTRICAL COMPONENTS – Navigation System – Ertf Unik IV

## 18 Wheels

- 18 WHEELS – Overview

## 19 Tools

- 19.1 Tooling Jack Stand
- 19.2 Specific tools

## 20 ANNEXES

- 20.1 Torque table – standard
- 20.2 Glue - Grease - Sealing
- 20.2 CAPACITIES

## Section 1

### Vehicle Overview

## 1.1.1 VEHICLE OVERVIEW – Size – Left and Right

Left view  
(Driver)

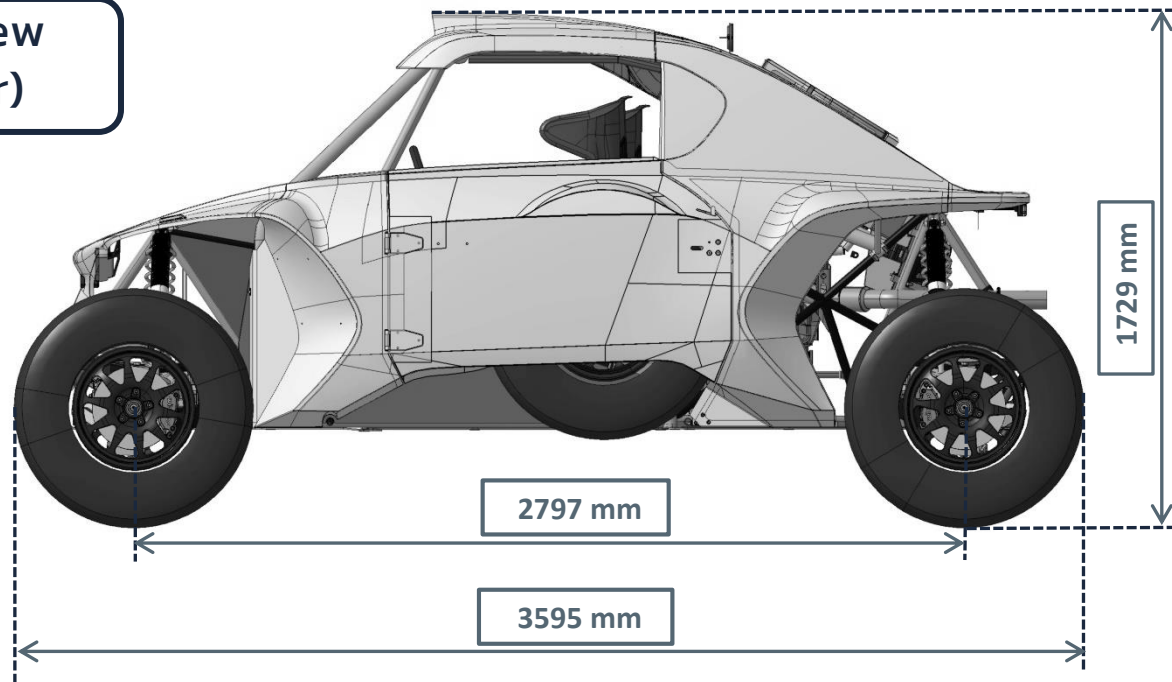

Right view  
(Co-Driver)

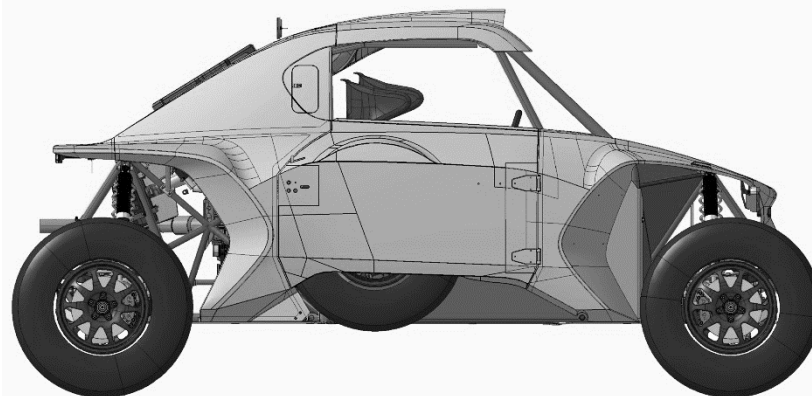

## 1.1.2 VEHICLE OVERVIEW – Size – Front and Back

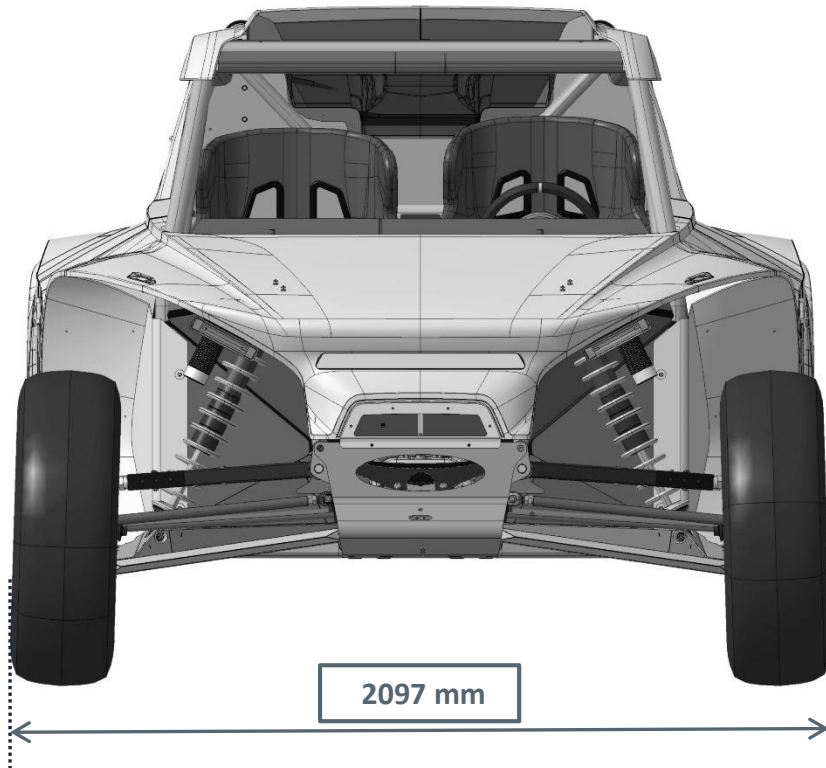

Front view

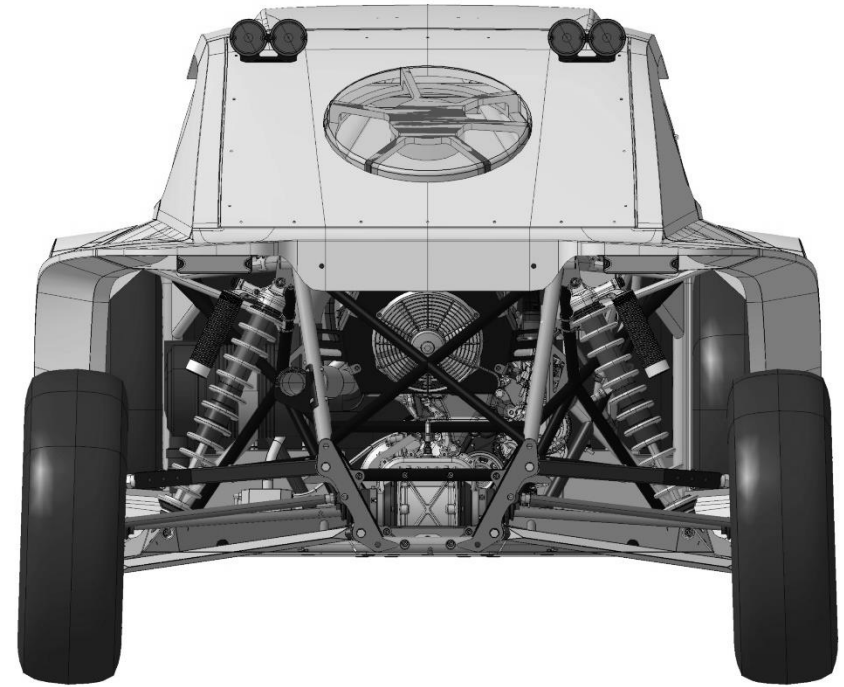

Back view



# 1.1.3 VEHICLE OVERVIEW – Size – Top and Bottom

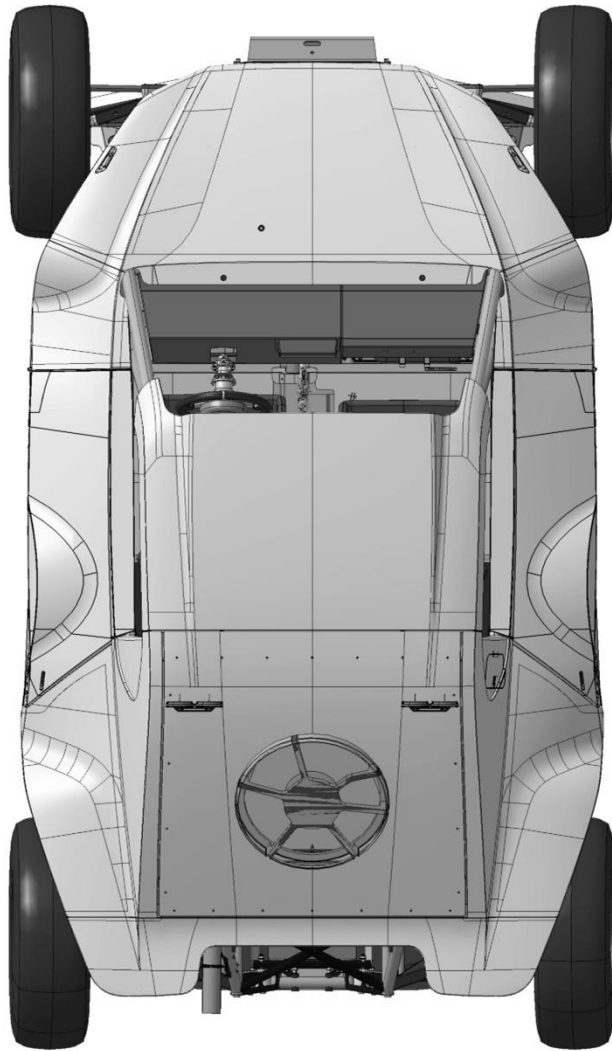

Top view

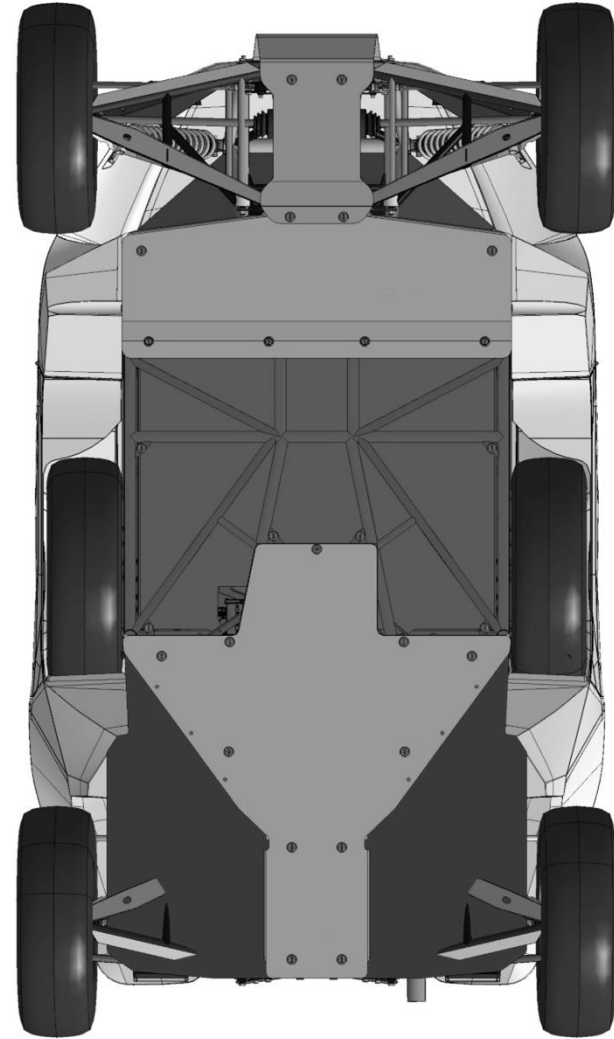

Bottom view

## 1.2 VEHICLE OVERVIEW – Transportation



### ■ For Cargo Pallet

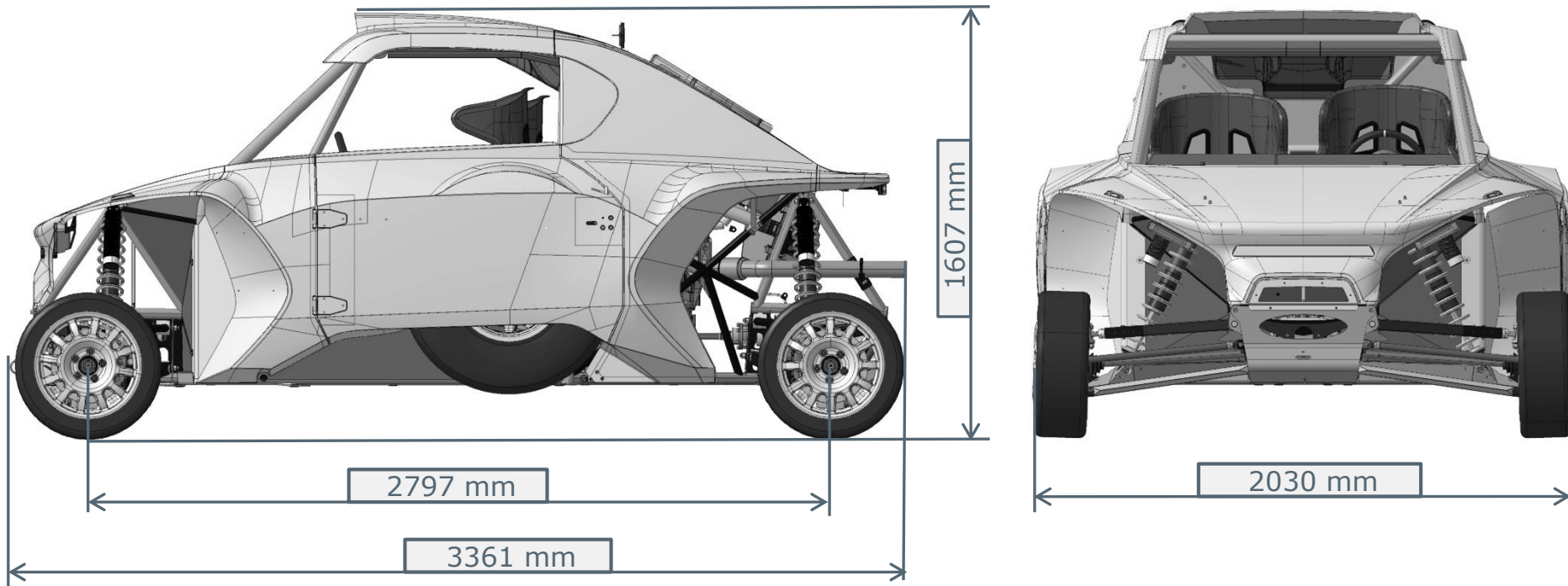

**Tire mounting: 195/45/R15**

## Section 2

### Chassis

## 2.2.1 CHASSIS – Preparation – Before painting

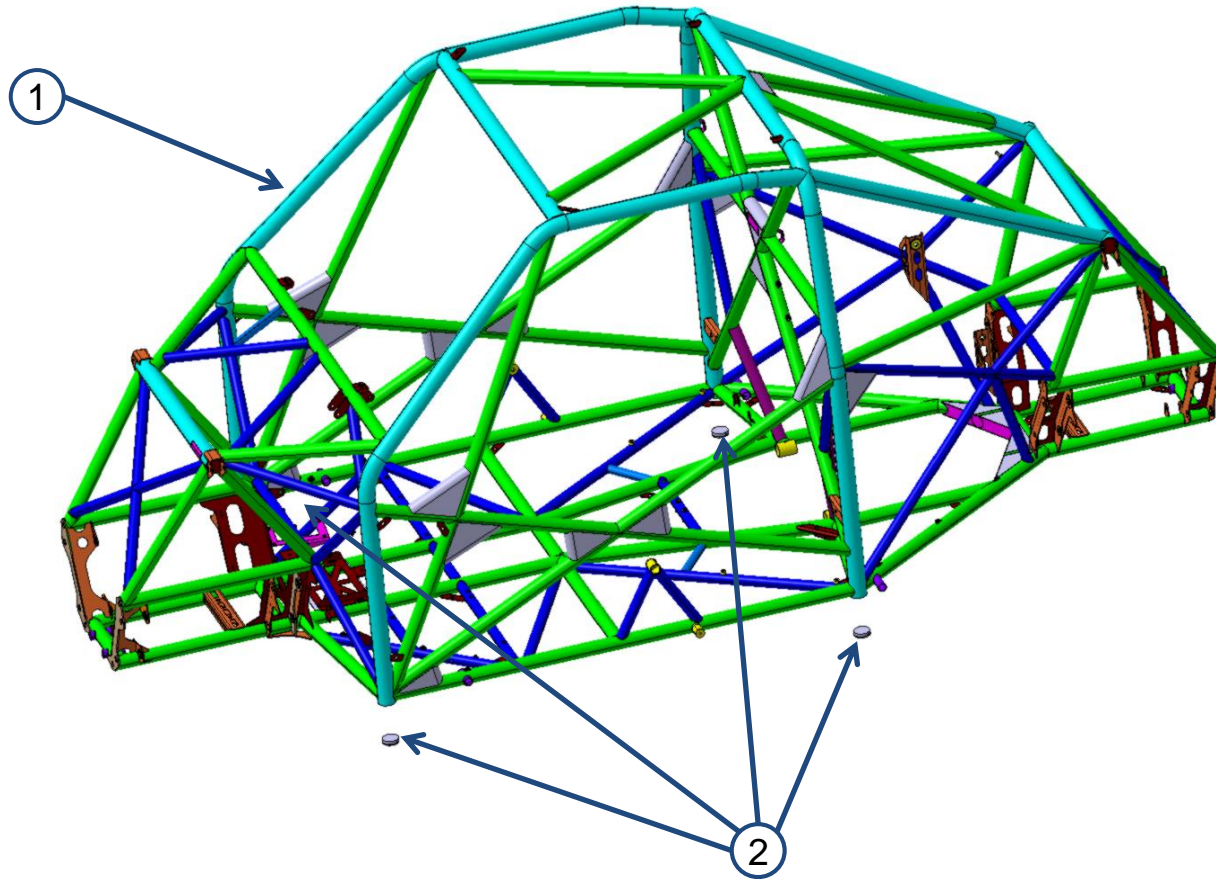

No.	Ref.	Name	Qty.
1	4012156	SASS - CHASSIS T3 MCE5	1
2	4013152	DRP - BOUCHONS ALU TUBES Ø50 ARCEAU PRINCIPAL	4

## 2.2.3 CHASSIS – Preparation – Heltape

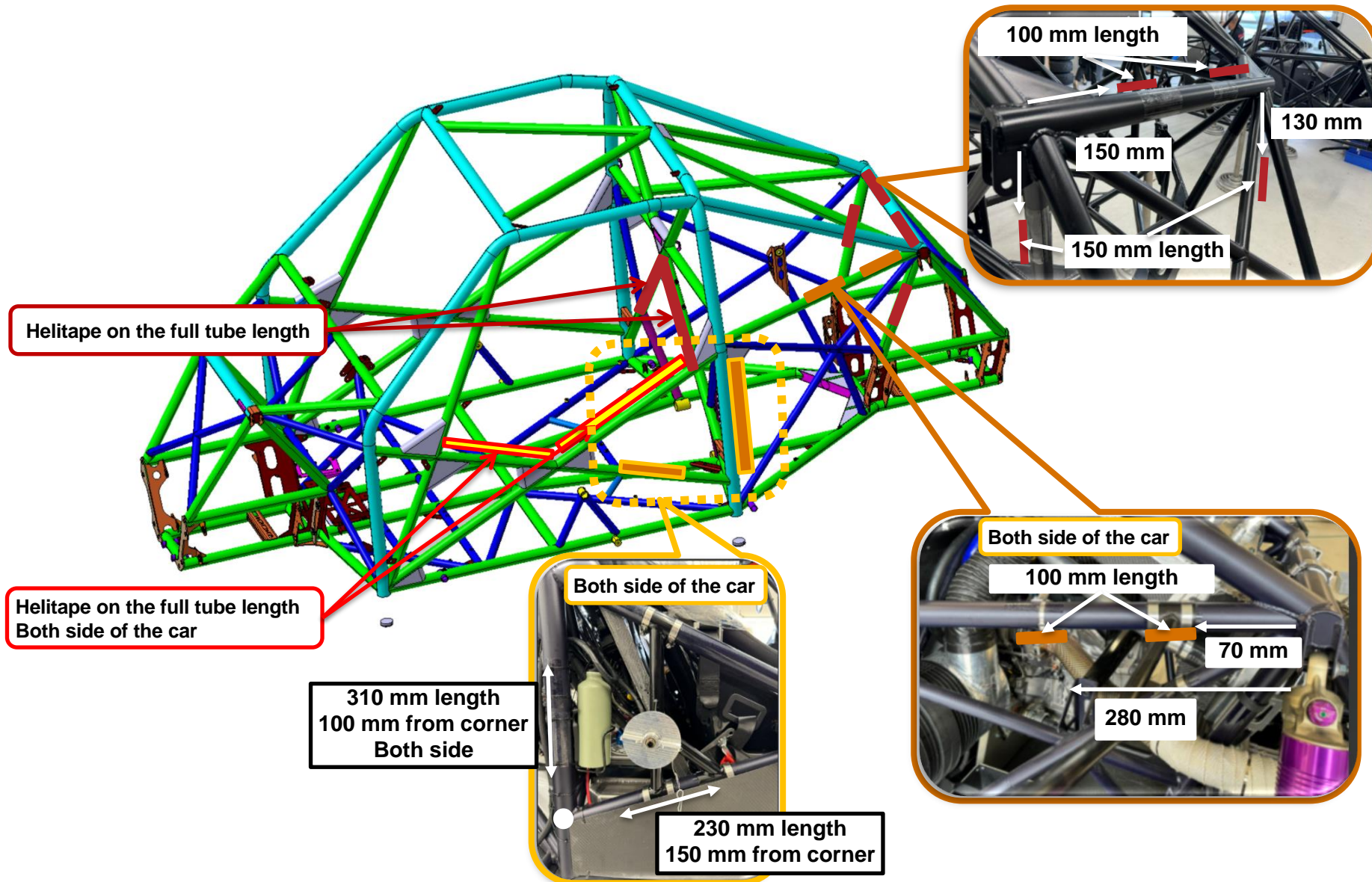

## 2.2.4 CHASSIS – Preparation – Helitape

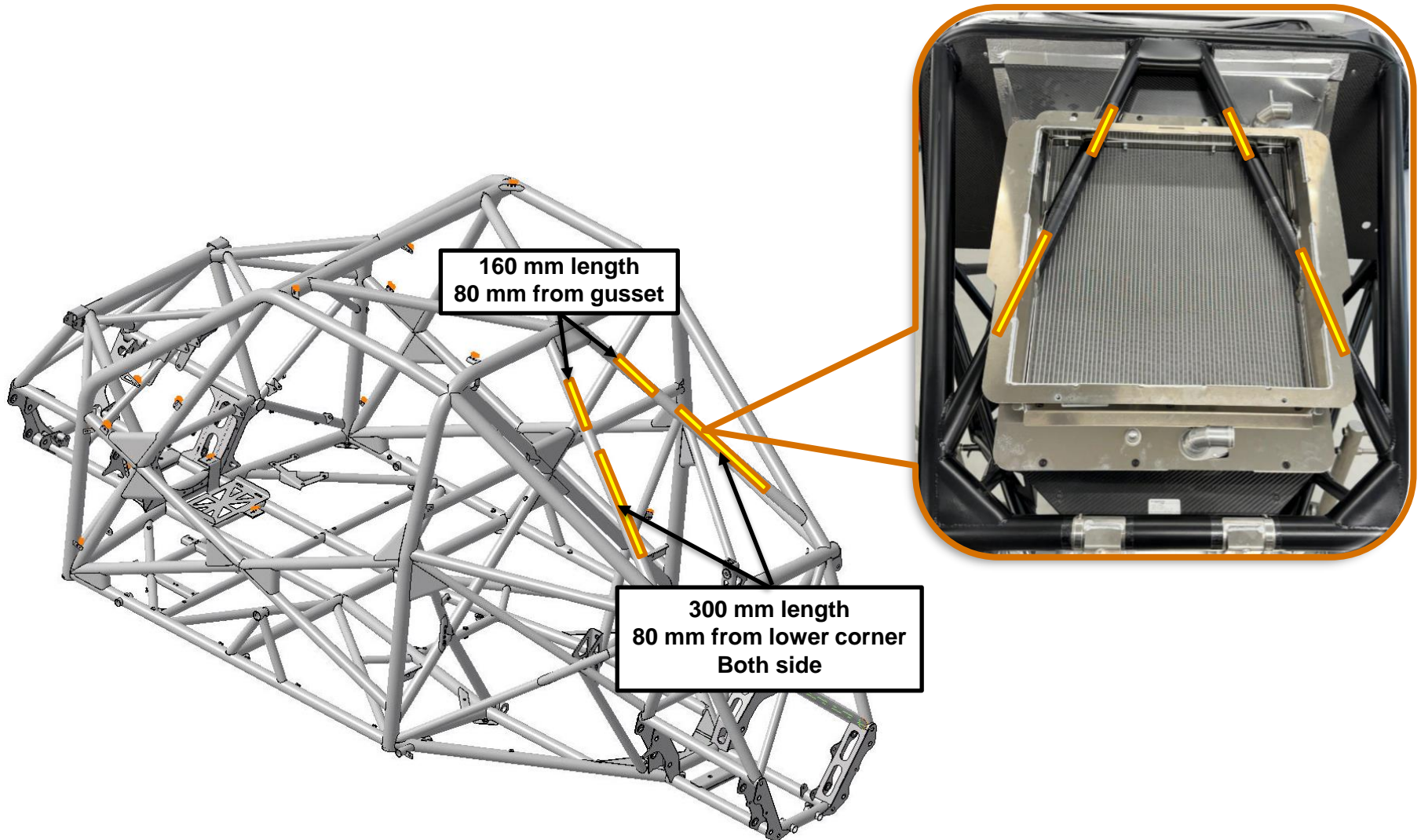

## 2.2.5 CHASSIS – Preparation – Ski nuts

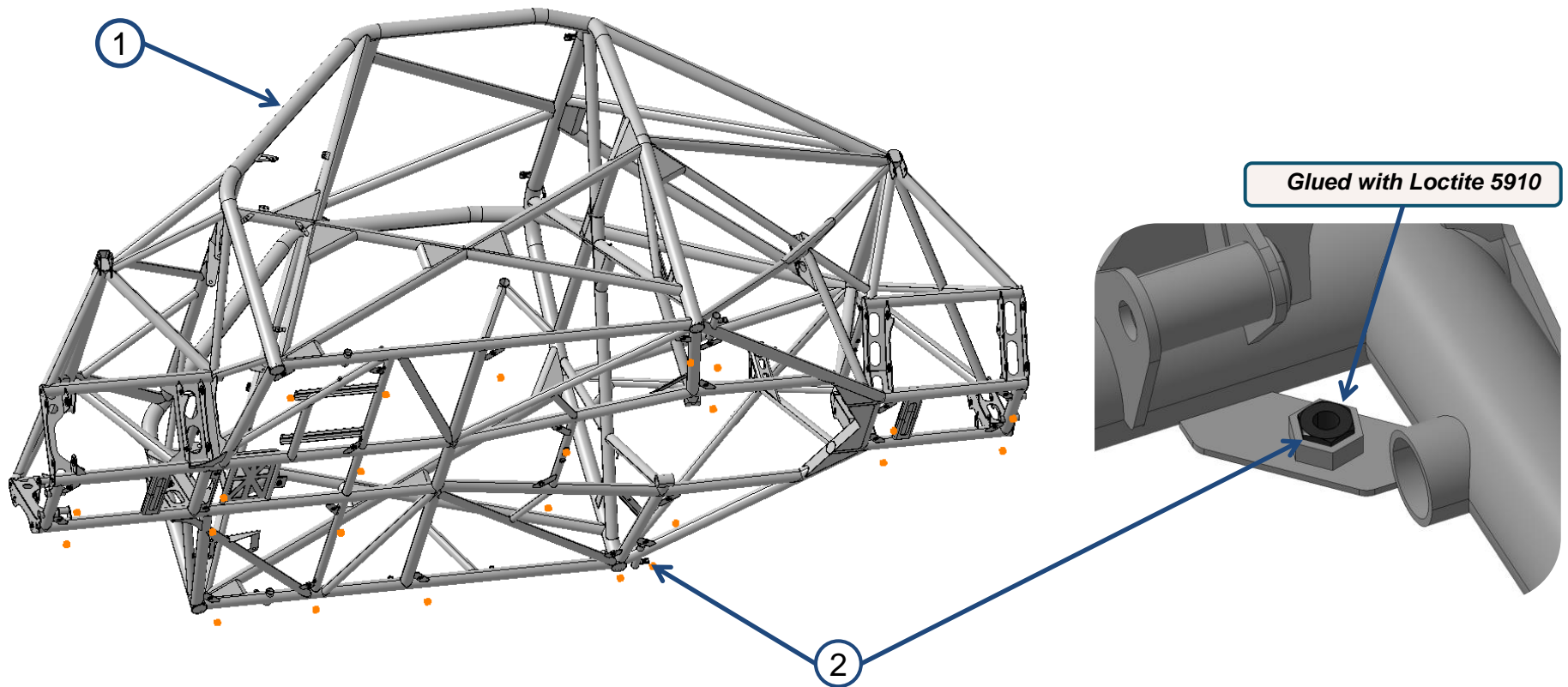

No.	Ref.	Name	Qty.
1	4012156	SASS - CHASSIS T3 MCE5	1
2	010131	SUP-ECROU HEXAGONAL M8 P125	24

## 2.2.6 CHASSIS – Preparation – Pinch nuts

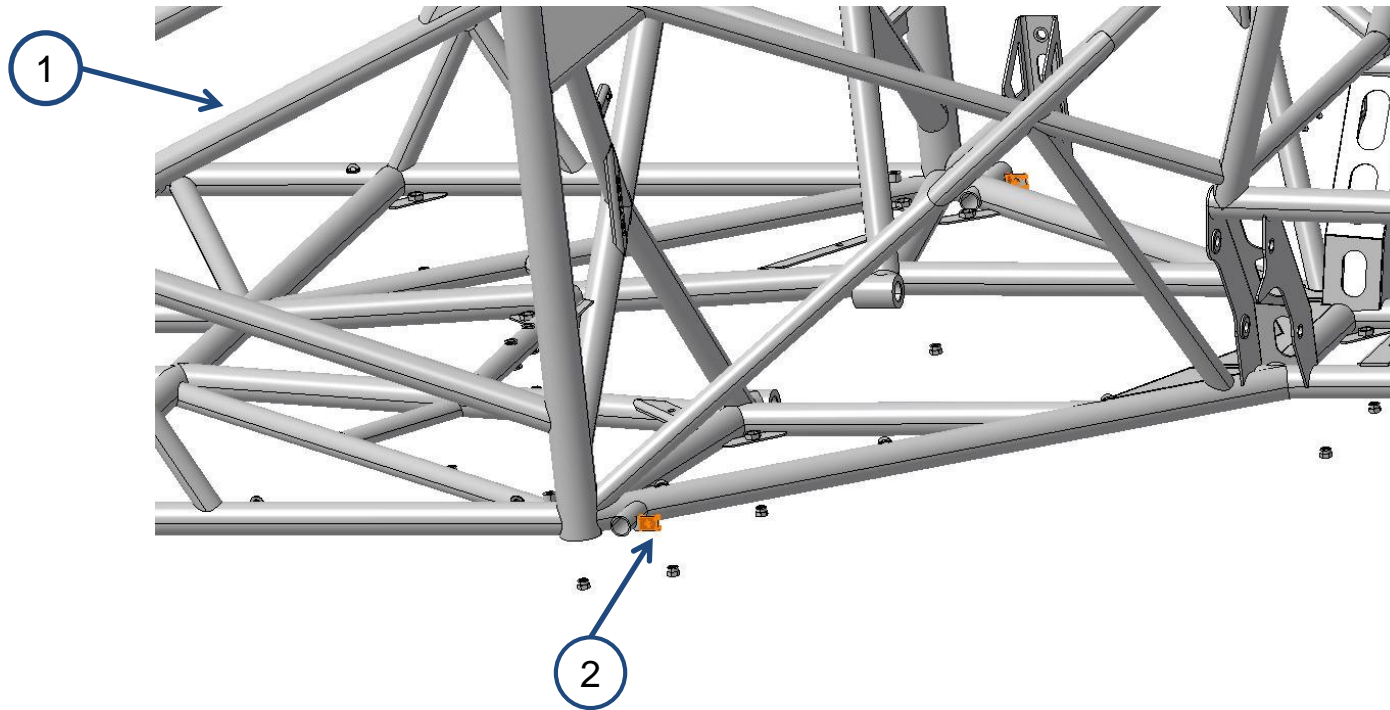

No.	Ref.	Name	Qty.
1	4012156	SASS - CHASSIS T3 MCE5	1
2	4013533	COP-NUT PINCH M6 - CERGY VIS - RPREM6013176016	2



## 2.2.7 CHASSIS– Preparation – Floating nuts

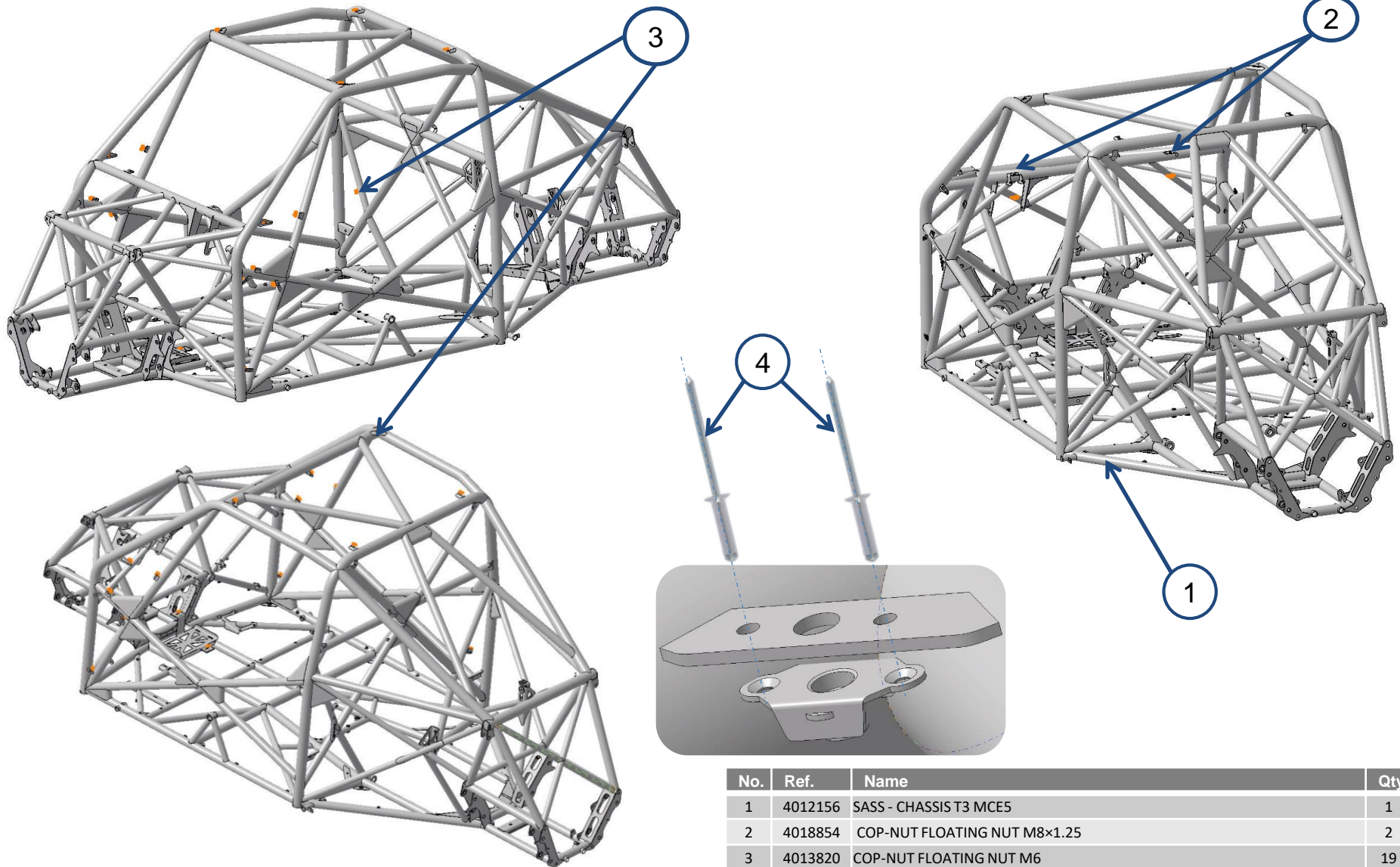

No.	Ref.	Name	Qty.
1	4012156	SASS - CHASSIS T3 MCE5	1
2	4018854	COP-NUT FLOATING NUT M8x1.25	2
3	4013820	COP-NUT FLOATING NUT M6	19
4	4013836	COP-RIVET	42

## 2.3.1 CHASSIS – Rear wall

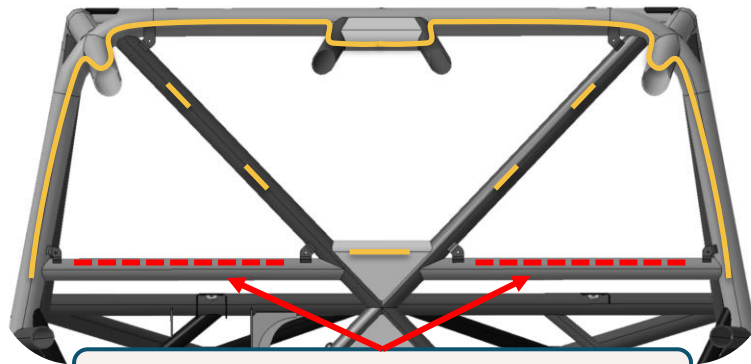

The rear wall is first glued to the chassis by following this pattern

NO GLUE on that areas ! Because of seat belt!

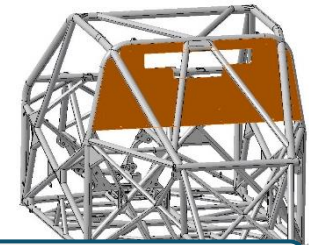

Be sur to be in the good position, Up to the middle of the tube!!

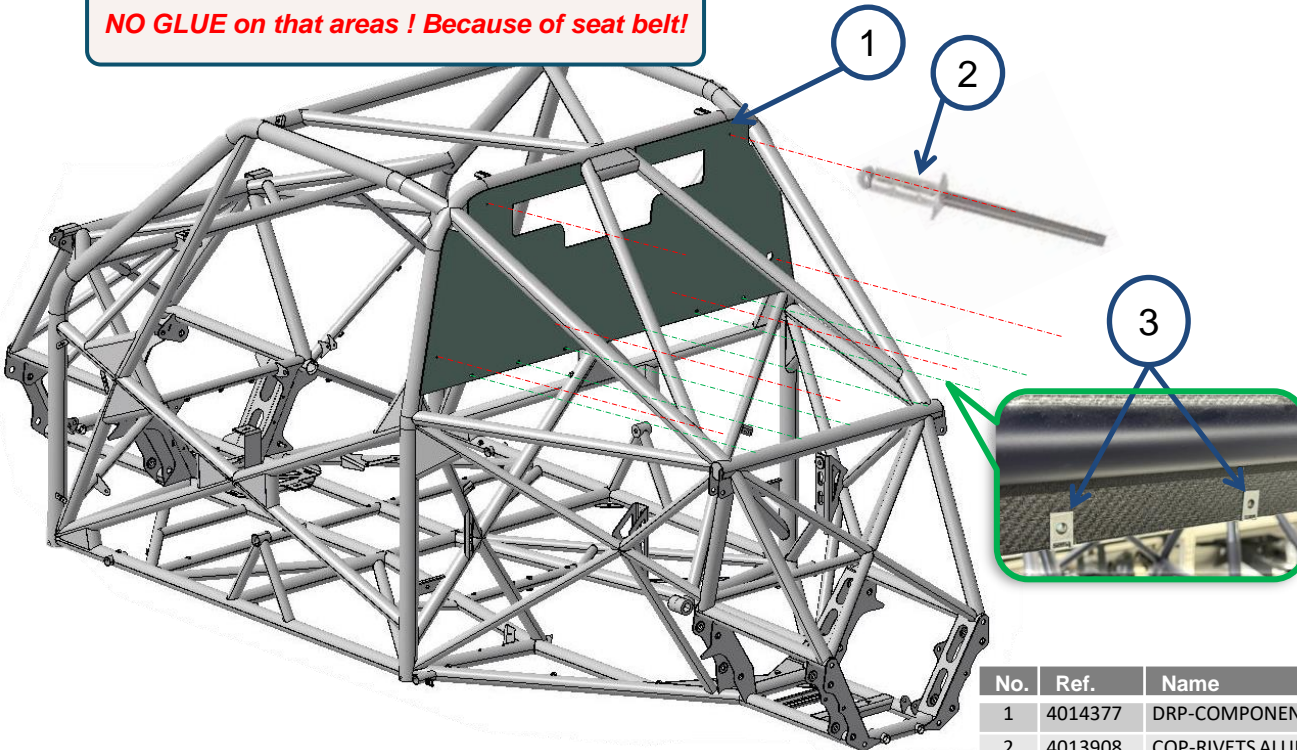
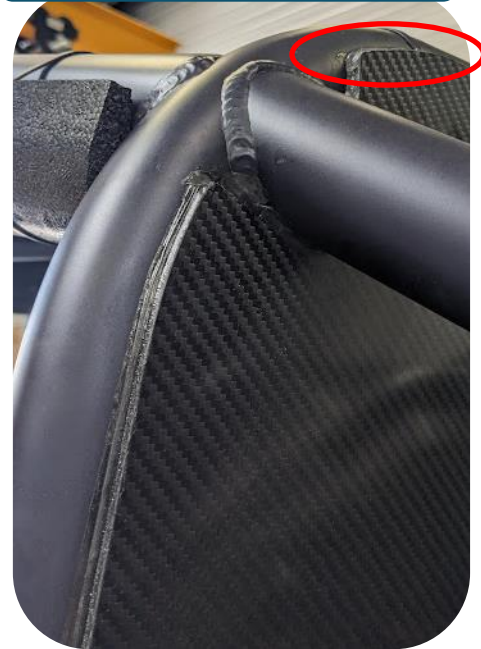

No.	Ref.	Name	Qty.
1	4014377	DRP-COMPONENT UPPER PARTITION COMPOSITE	1
2	4013908	COP-RIVETS ALUMINIUM	6
3	4013533	COP-NUT PINCH M6	6

## 2.3.2.1 CHASSIS – Air Vein Composite – Top

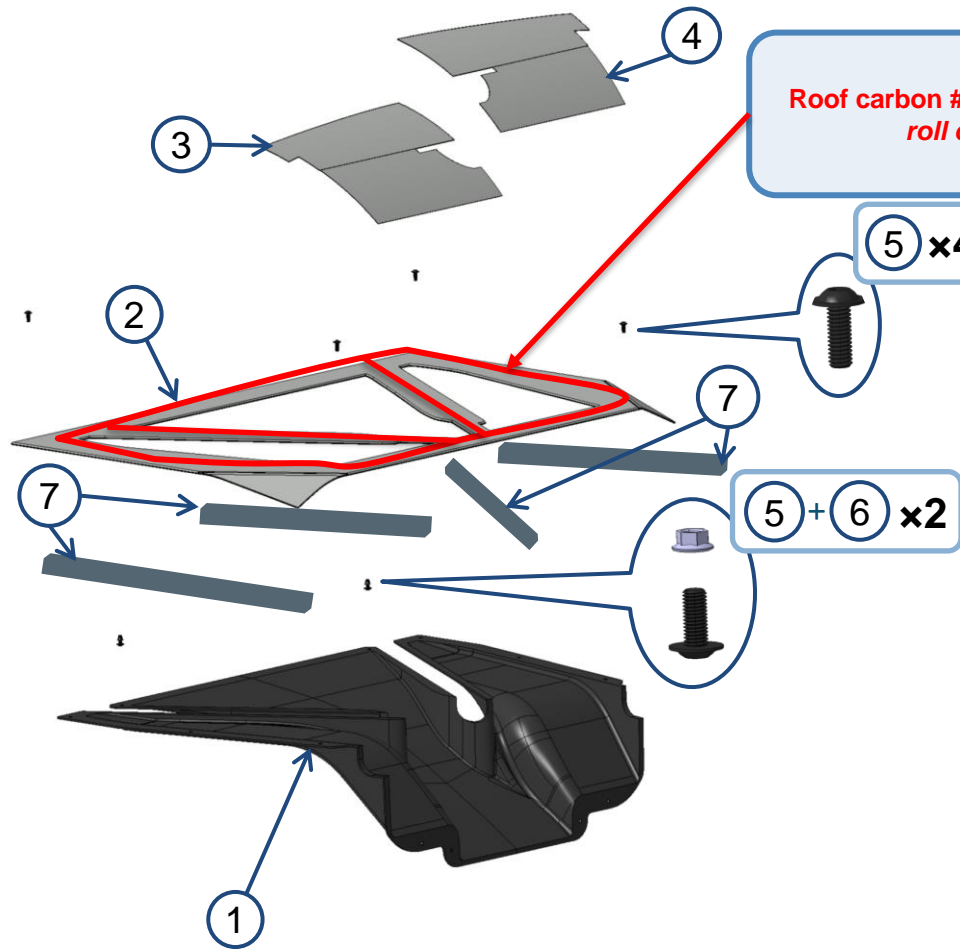
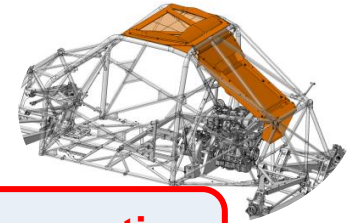

Roof carbon #2 is glued on roll cage

Must be done @ same time than the roll pads – P.26



No.	Ref.	Name	Qty.
1	4013854	DRP-DEFLECTOR MAIN - CREW AREA	1
2	4014481	DRP-COMPONENT ROOF CARBON - CREW AREA	1
3	4014839	DRP-COMPONENT TOP DEFLECTOR LEFT - ENGINE AREA	1
4	4014840	DRP-COMPONENT TOP DEFLECTOR RIGHT - ENGINE AREA	1
5	4013534	COP-SCREW BUTTON HEAD WITH FLANGE	12
6	4013685	SUP-LOCKNUT WITH FLANGE	8
7	4016940	COP-FOAM	1

## 2.3.2.2 CHASSIS – Air Vein Composite – Top flaps

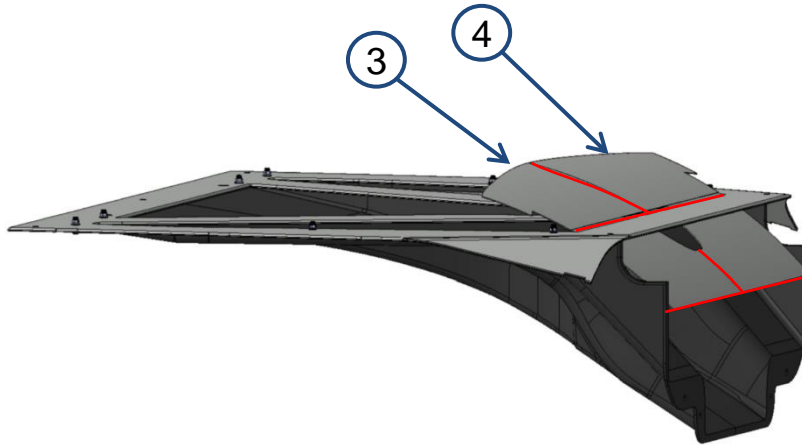
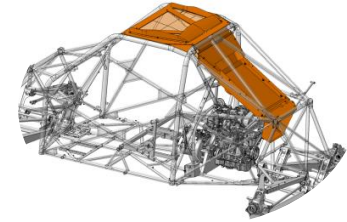

**Parts #3 and #4 must be taped together AND with the parts around**

**Use Helitape**

No.	Ref.	Name	Qty.
3	4014839	DRP-COMPONENT TOP DEFLECTOR LEFT - ENGINE AREA	1
4	4014840	DRP-COMPONENT TOP DEFLECTOR RIGHT - ENGINE AREA	1

## 2.3.2.3 CHASSIS – Roll Bar Protection Foam

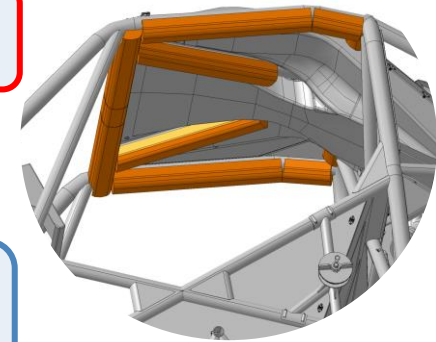
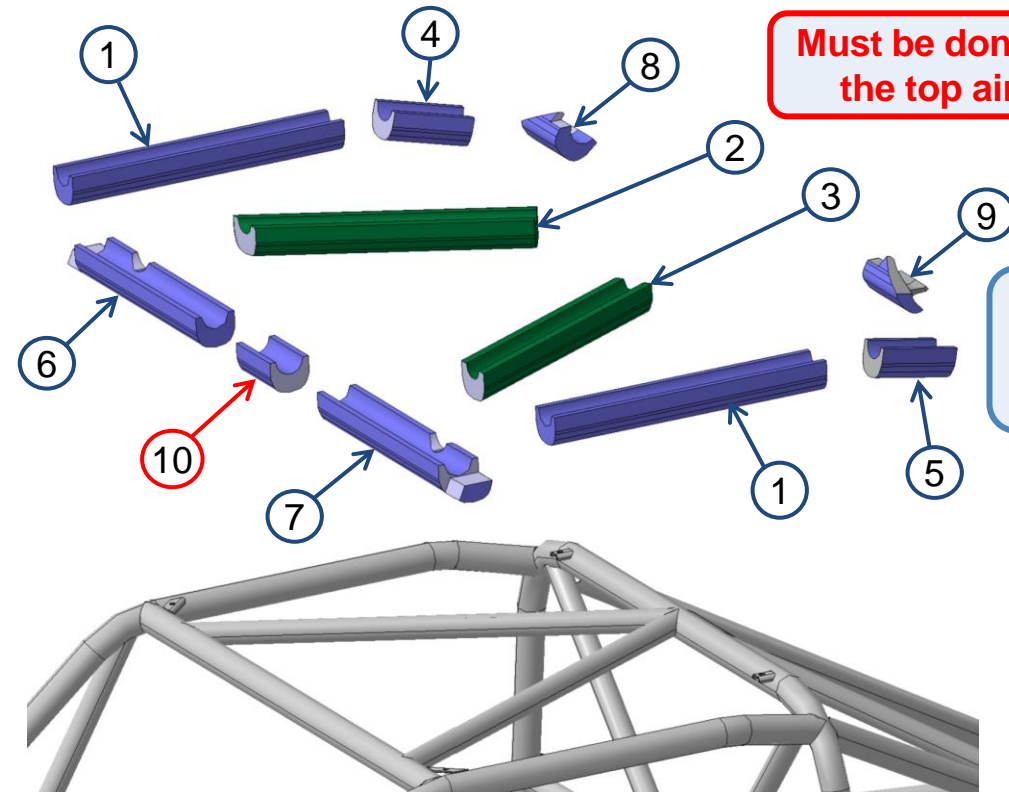

**Use large plastic cable ties (7mm width) to secure the protective foam:**

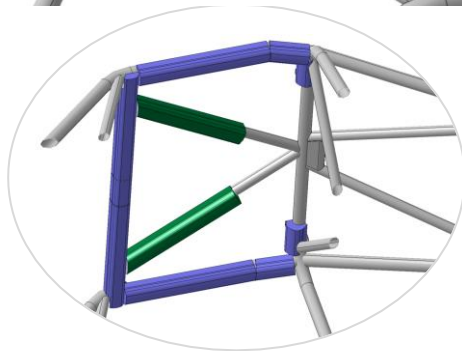

No.	Ref.	Name	Qty.
1	4013314	COP-ROLL BAR PROTECTIVE FOAM - Ø50 L500	2
2	4014573	DRP-COMPONENT ROLL BAR PROTECTIVE FOAM - Ø38 – RIGHT	1
3	4014574	DRP-COMPONENT ROLL BAR PROTECTIVE FOAM - Ø38 – LEFT	1
4	4014577	DRP-COMPONENT ROLL BAR PROTECTIVE FOAM - Ø50 - REAR RIGHT LATERAL	1
5	4014578	DRP-COMPONENT ROLL BAR PROTECTIVE FOAM - Ø50 - REAR LEFT LATERAL	1
6	4014579	DRP-COMPONENT ROLL BAR PROTECTIVE FOAM - Ø50 - FRONT RIGHT	1
7	4014580	DRP-COMPONENT ROLL BAR PROTECTIVE FOAM - Ø50 - FRONT LEFT	1
8	4015031	DRP-COMPONENT ROLL BAR PROTECTIVE FOAM - Ø50 - REAR RIGHT	1
9	4015032	DRP-COMPONENT ROLL BAR PROTECTIVE FOAM - Ø50 - REAR LEFT	1
10	4015033	DRP-COMPONENT ROLL BAR PROTECTIVE FOAM - Ø50 - FRONT CENTRAL	1

## 2.3.3 CHASSIS– Window Net

*Please install the net after assembling the air vein and vertical partition.*

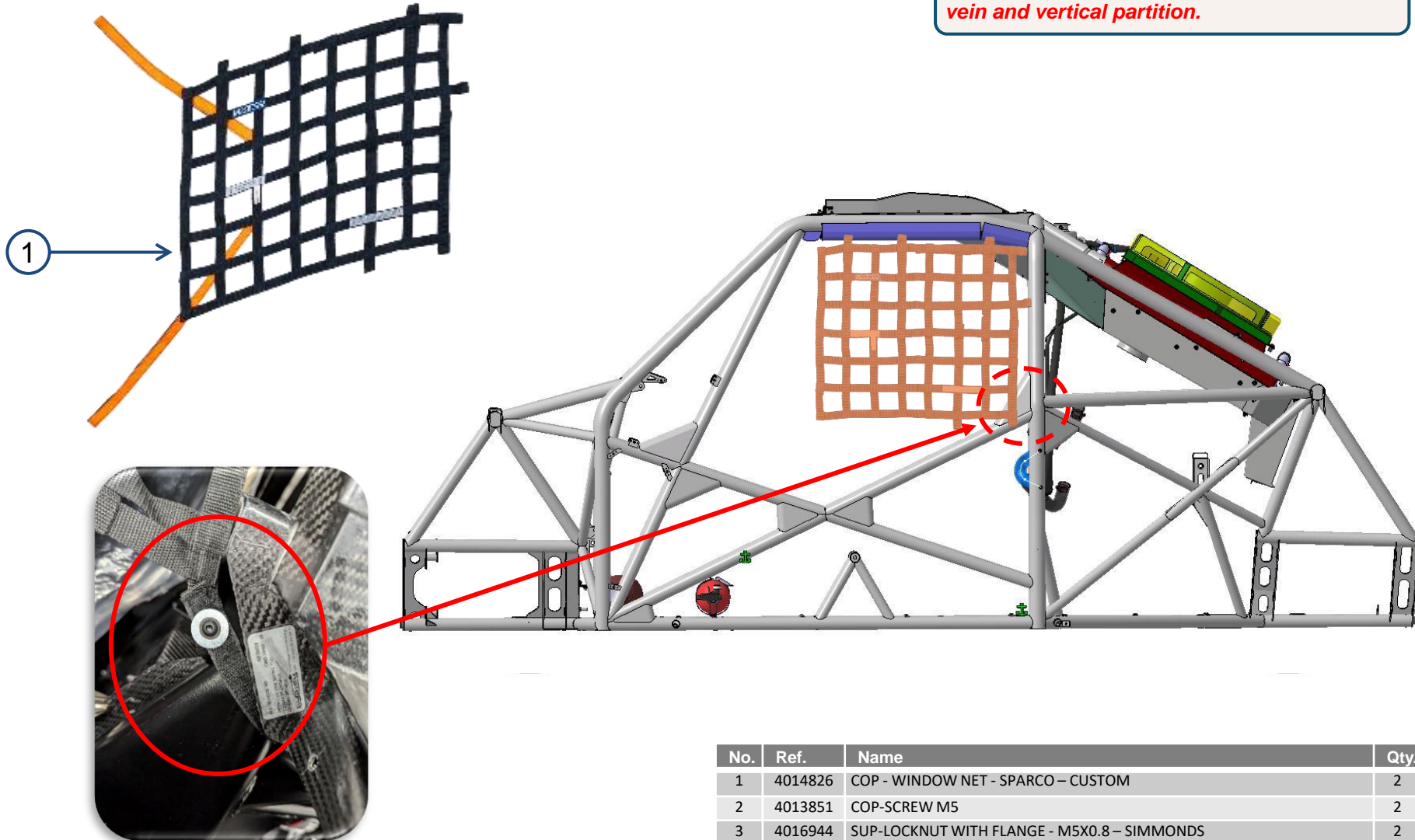

No.	Ref.	Name	Qty.
1	4014826	COP - WINDOW NET - SPARCO – CUSTOM	2
2	4013851	COP-SCREW M5	2
3	4016944	SUP-LOCKNUT WITH FLANGE - M5X0.8 – SIMMONDS	2
4	4021061	SUP-WASHER M5 BIG - 000 730 183	4

## 2.3.4.1 CHASSIS – Exterior Walls – Composite 2023

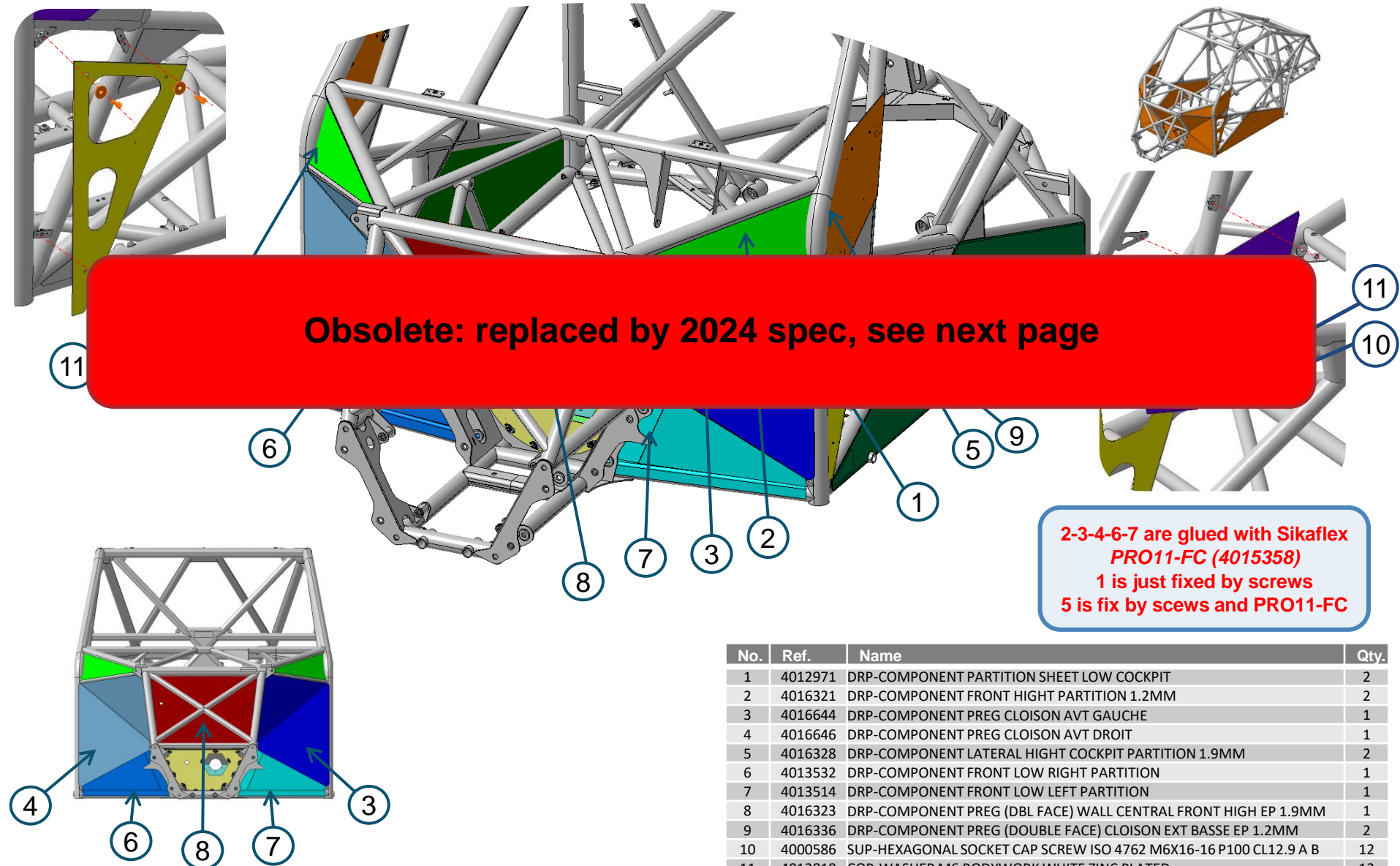

**Obsolete: replaced by 2024 spec, see next page**

2-3-4-6-7 are glued with Sikaflex PRO11-FC (4015358)  
 1 is just fixed by screws  
 5 is fix by scews and PRO11-FC

No.	Ref.	Name	Qty.
1	4012971	DRP-COMPONENT PARTITION SHEET LOW COCKPIT	2
2	4016321	DRP-COMPONENT FRONT HIGHT PARTITION 1.2MM	2
3	4016644	DRP-COMPONENT PREG CLOISON AVT GAUCHE	1
4	4016646	DRP-COMPONENT PREG CLOISON AVT DROIT	1
5	4016328	DRP-COMPONENT LATERAL HIGHT COCKPIT PARTITION 1.9MM	2
6	4013532	DRP-COMPONENT FRONT LOW RIGHT PARTITION	1
7	4013514	DRP-COMPONENT FRONT LOW LEFT PARTITION	1
8	4016323	DRP-COMPONENT PREG (DBL FACE) WALL CENTRAL FRONT HIGH EP 1.9MM	1
9	4016336	DRP-COMPONENT PREG (DOUBLE FACE) CLOISON EXT BASSE EP 1.2MM	2
10	4000586	SUP-HEXAGONAL SOCKET CAP SCREW ISO 4762 M6X16-16 P100 CL12.9 A B	12
11	4013818	COP-WASHER M6 BODYWORK WHITE ZINC PLATED	12

## 2.3.4.2 CHASSIS – Exterior Walls – Composite 2024

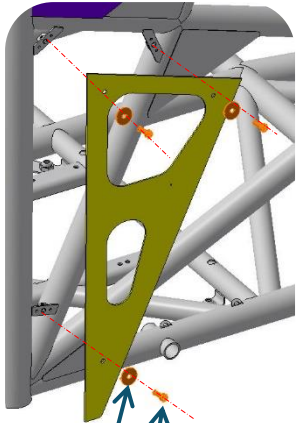

11  
10

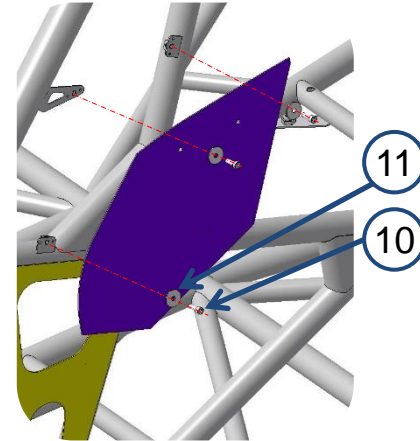
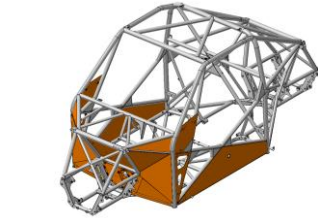
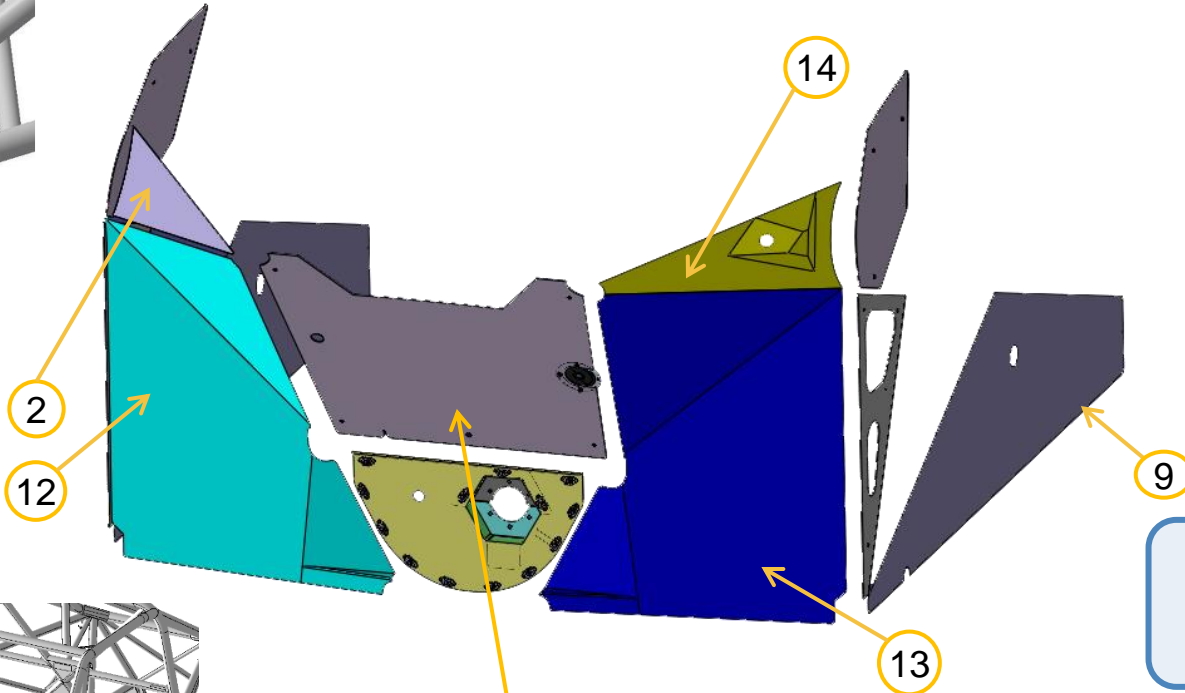

11

10

2-3-4-6-7 are glued  
1 is just fixed by screws  
5 is fix by screws

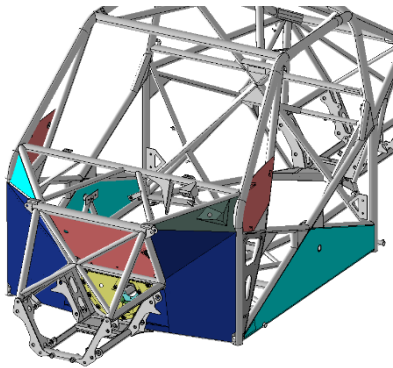

15

No.	Ref.	Name	Qty.
2	4016321	DRP-COMPONENT FRONT HIGHT PARTITION 1.2MM	1
9	4016336	DRP-COMPONENT PREG (DOUBLE FACE) CLOISON EXT BASSE EP 1.2MM	2
10	4000586	SUP-HEXAGONAL SOCKET CAP SCREW ISO 4762 M6X16-16 P100 CL12.9 A B	12
11	4013818	COP-WASHER M6 BODYWORK WHITE ZINC PLATED	12
12	4019933	DRP-COMPONENT WHEEL ARCH GUARD - RIGHT	1
13	4019934	DRP-COMPONENT WHEEL ARCH GUARD - LEF	1
14	4021888	DRP-COMPONENT WIPER CLOSING PANNEL	1
15	4019936	DRP-HIGHT FRONT CENTRAL WALL TH 1.9MM	1



## 2.3.4.3 CHASSIS– Exterior Walls – Direction Grommet Seal

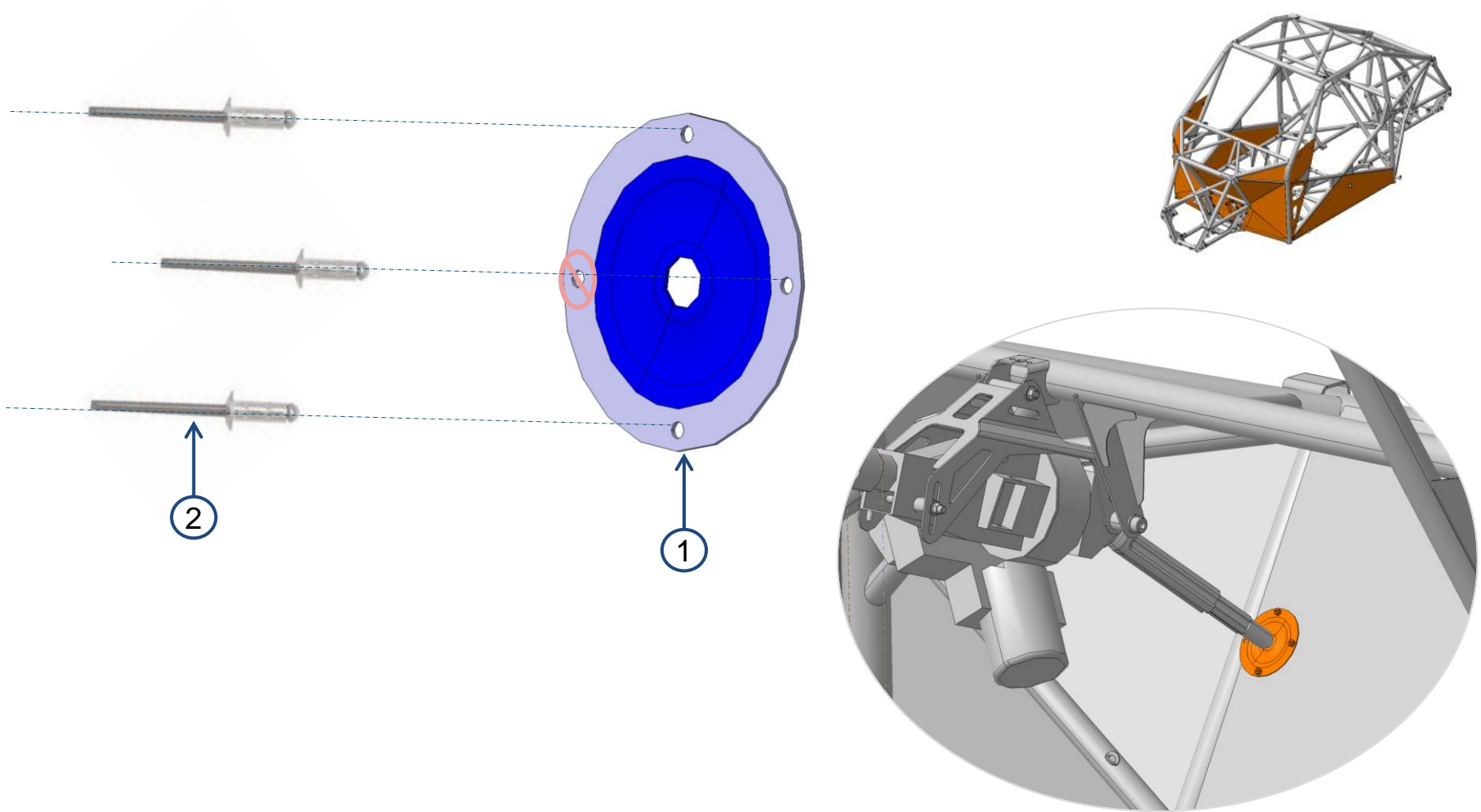

No.	Ref.	Name	Qty.
1	4013530	COP GROMMET SEAL ØINT 12 - ØEXT 76	1
2	4016946	COP-TO BE DEFINED RIVET M3X6 TETE PLATE	3

## 2.3.5 CHASSIS – Exterior Walls – Shaft guard

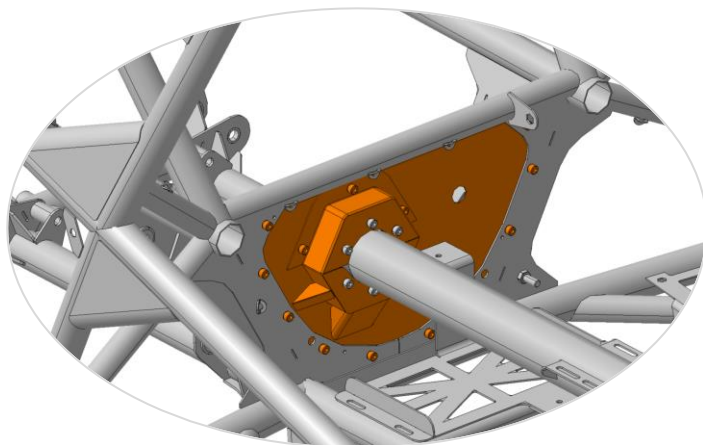
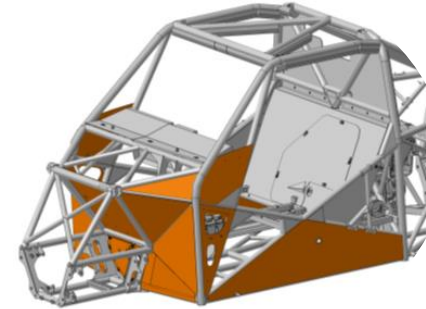
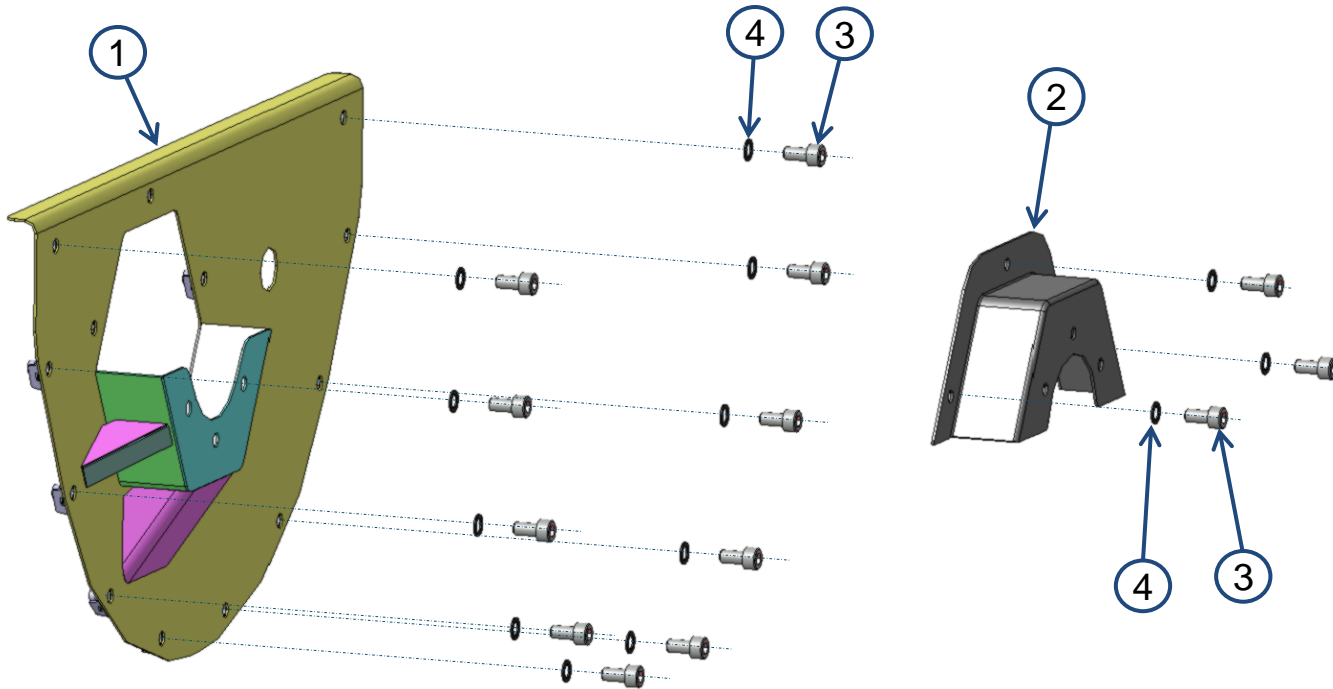

No.	Ref.	Name	Qty.
1	4013623	DRP-WALL - CENTRAL FRONT – WELDED	1
2	4014835	DRP-COMPONENT COVER WALL - CENTRAL FRONT – CARBON	1
3	4000931	SUP-HEXAGONAL SOCKET CAP SCREW	13
4	4014024	COP-WASHER Ø6 SCHNORR	13

## Section 3

### Rigid lines

### ■ Specific tool needed

- ▶ **SAW**
- ▶ **MANUAL M6 TAP**

### ■ Specific sealing needed:

- ▶ **Loctite 271**

# 3.1 RIGIDE LINES – Braking circuit

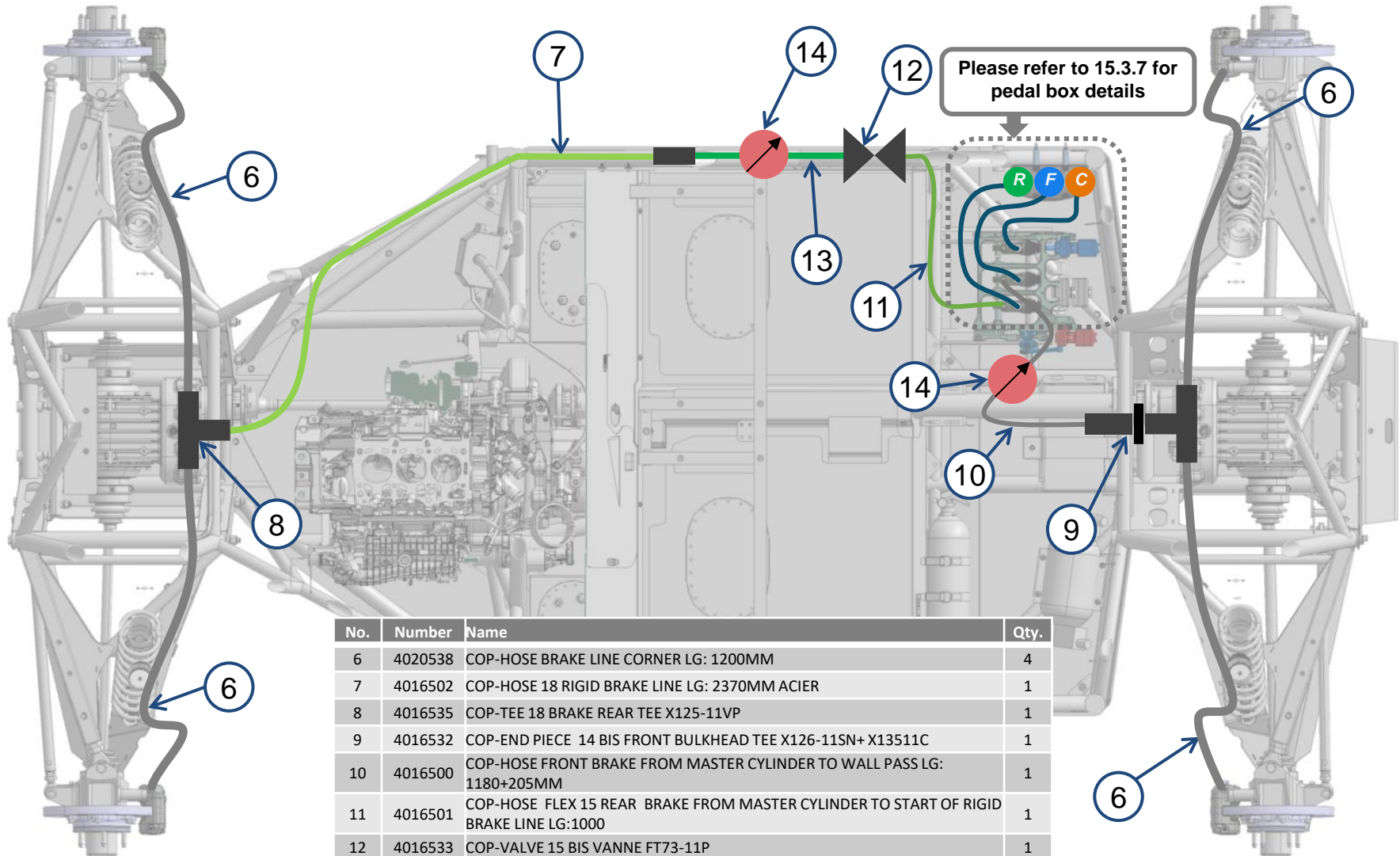

No.	Number	Name	Qty.
6	4020538	COP-HOSE BRAKE LINE CORNER LG: 1200MM	4
7	4016502	COP-HOSE 18 RIGID BRAKE LINE LG: 2370MM ACIER	1
8	4016535	COP-TEE 18 BRAKE REAR TEE X125-11VP	1
9	4016532	COP-END PIECE 14 BIS FRONT BULKHEAD TEE X126-11SN+ X13511C	1
10	4016500	COP-HOSE FRONT BRAKE FROM MASTER CYLINDER TO WALL PASS LG: 1180+205MM	1
11	4016501	COP-HOSE FLEX 15 REAR BRAKE FROM MASTER CYLINDER TO START OF RIGID BRAKE LINE LG:1000	1
12	4016533	COP-VALVE 15 BIS VANNE FT73-11P	1
13	4016534	COP-HOSE FLEX 16-17 BRAKE REAR CAPTEUR 550+ 90MM	1
14	4016597	SASS-HARNESS FRONT AND REAR BRAKES PRESSURE WIRING	2

## 3.2 RIGIDE LINES– Clutch – Circuit

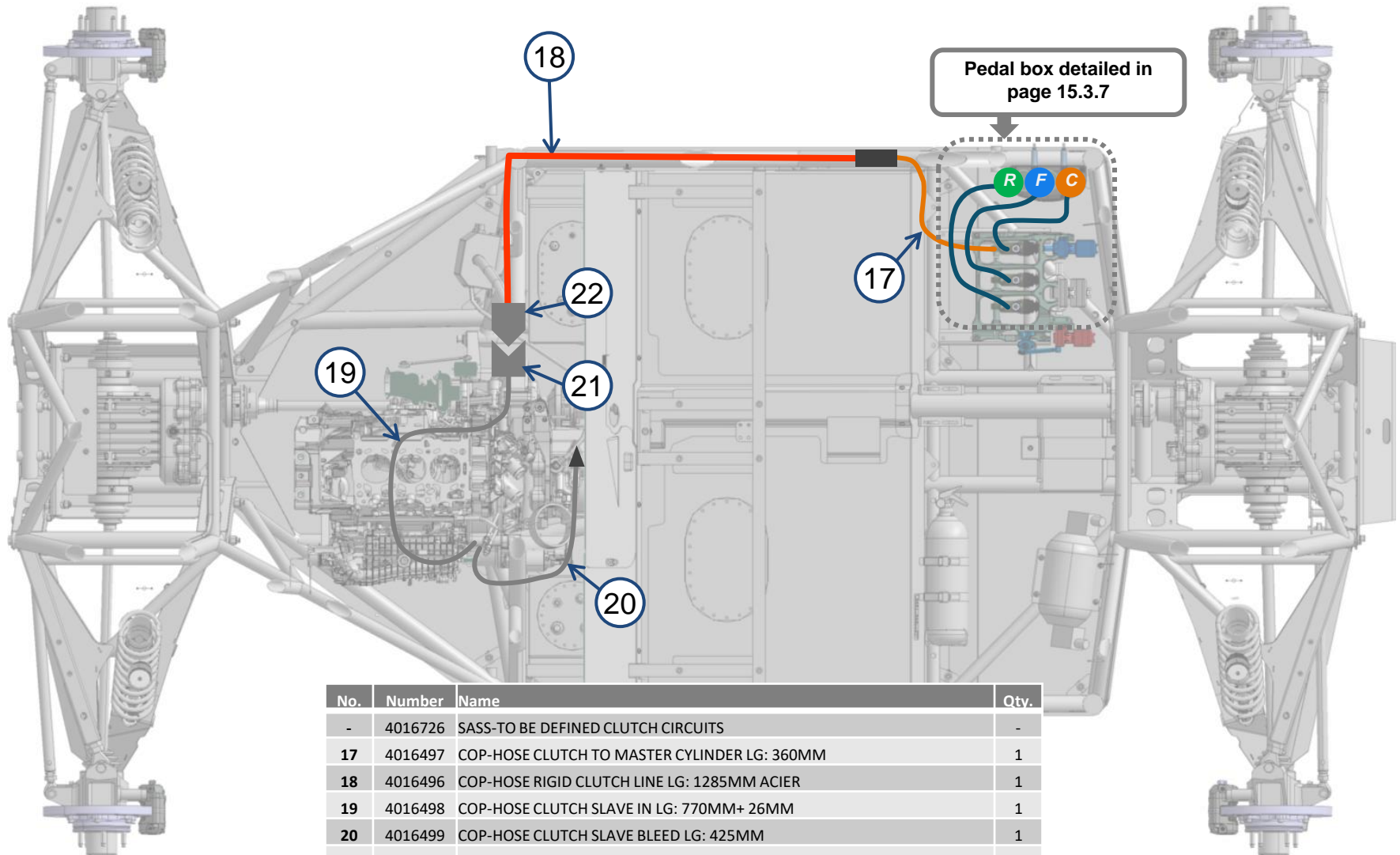

No.	Number	Name	Qty.
-	4016726	SASS-TO BE DEFINED CLUTCH CIRCUITS	-
17	4016497	COP-HOSE CLUTCH TO MASTER CYLINDER LG: 360MM	1
18	4016496	COP-HOSE RIGID CLUTCH LINE LG: 1285MM ACIER	1
19	4016498	COP-HOSE CLUTCH SLAVE IN LG: 770MM+ 26MM	1
20	4016499	COP-HOSE CLUTCH SLAVE BLEED LG: 425MM	1
21	4012955	COP-RACCORD STAUBLI SPH FEMELE 3/8-24 EPDM	1
22	4012954	COP-RACCORD STAUBLI SPH MALE 3/8-24 EPDM	1

### 3.4 RIGIDE LINES – Fire Extinguisher Kit – Circuit details

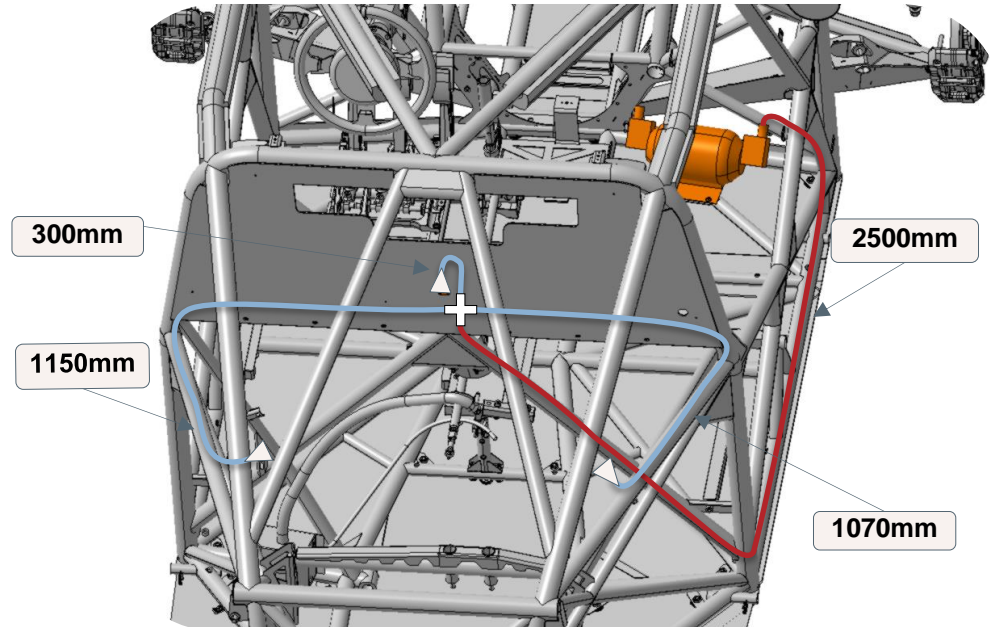
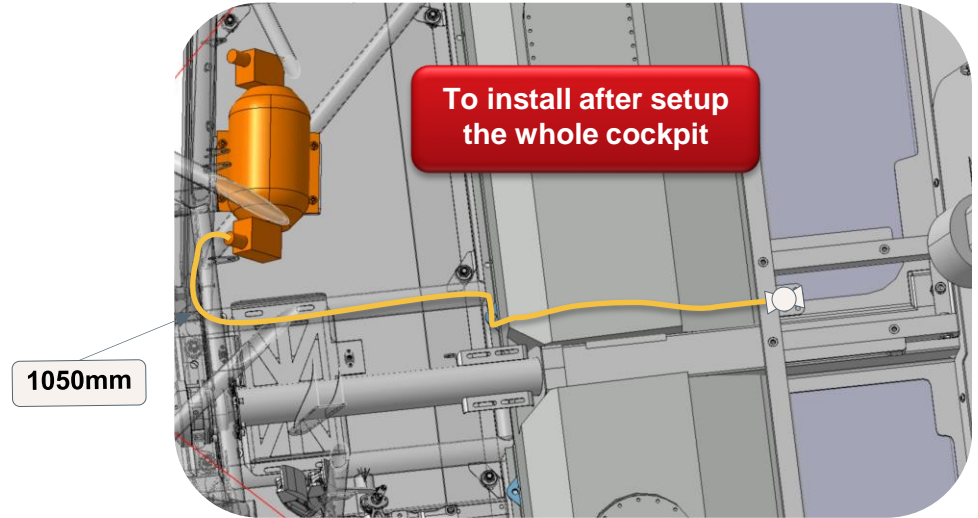
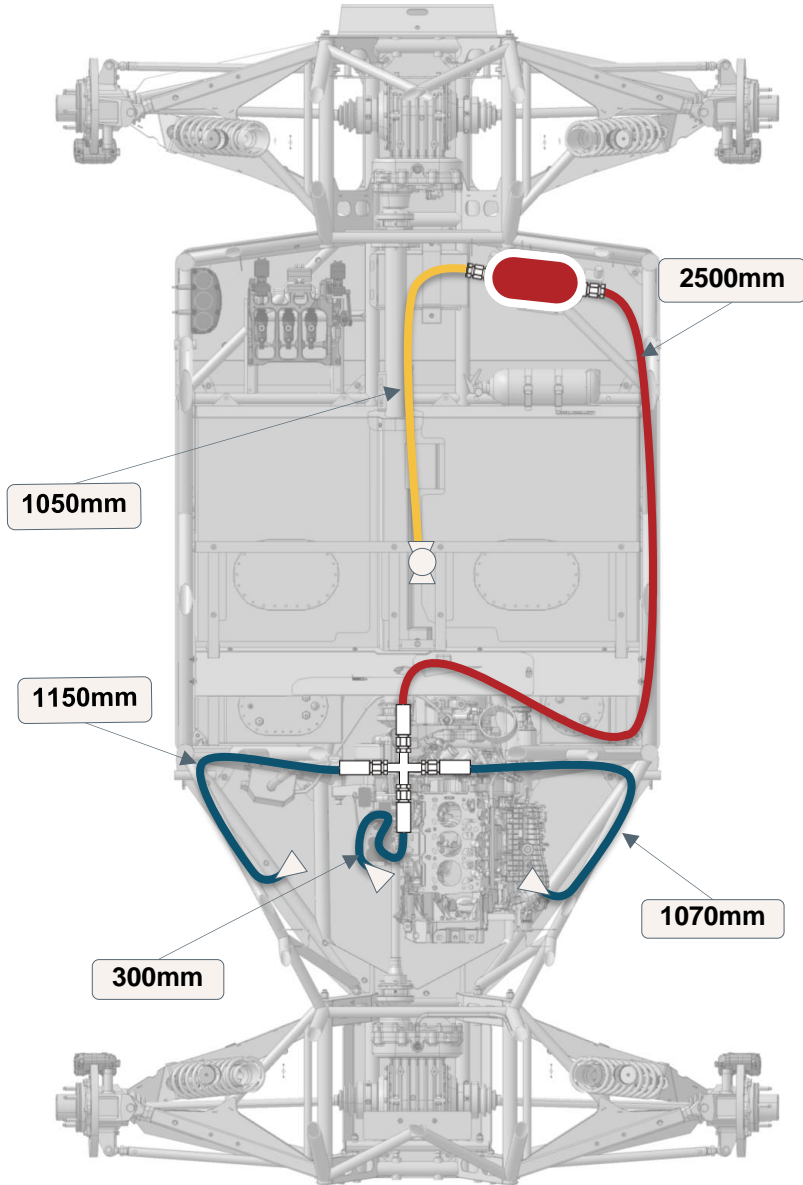

### 3.4.1 RIGIDE LINES – Fire Extinguishers – Overview

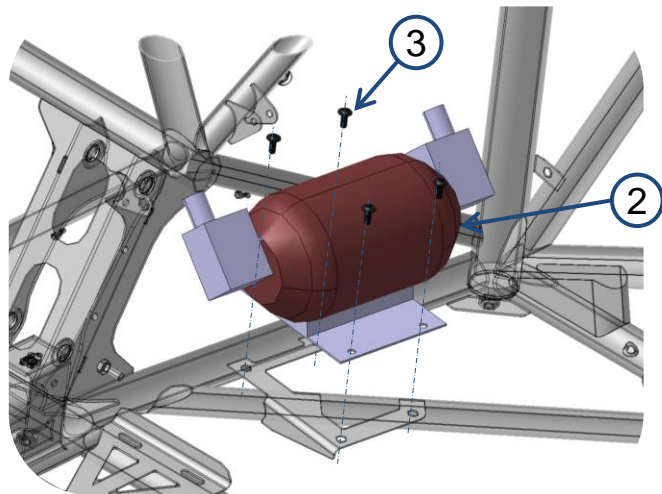

**Extinguisher stickers must be visible**

**Plastique tie rap to replace by metallic one on final assembly**

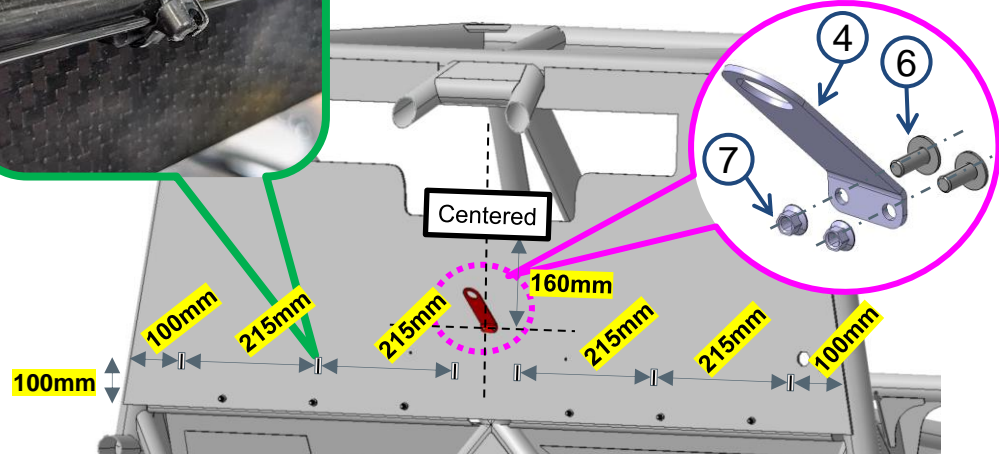
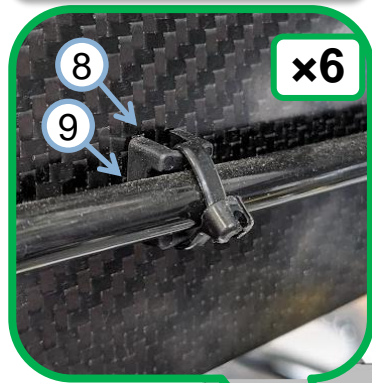

No.	Ref.	Name	Qty.
1	4013091	COP-FIRE EXTINGUISHER 2KG FIA EN3	1
2	4012722	COP-FIRE EXTINGUISHER ELEC FIA - LIFELINE KIT ZERO 275	1
3	4013534	COP-VIS TBHCEM - M6X16 P100 - CL10.9 – NOIRE	6
4	4014830	DRP-COMPONENT EXTINGUISHER NOZZLE HOLDER	1
5	4013685	SUP-LOCKNUT WITH FLANGE - M6X1.00 - SIMMONDS	2
6	4013851	COP-SCREW VIS A EMBASE TETE BASSE M5X12	2
7	4016944	SUP-LOCKNUT WITH FLANGE - M5X0.8 - SIMMONDS	2
8	4013573	COP-TO BE DEFINED EMBASE DE COLLIER A VISSER	6
9	4016996	COP-TO BE DEFINED RIVET M3X10 TETE FRAISEE	6



### 3.4.2 RIGIDE LINES – Fire Extinguisher Kit – Circuit details

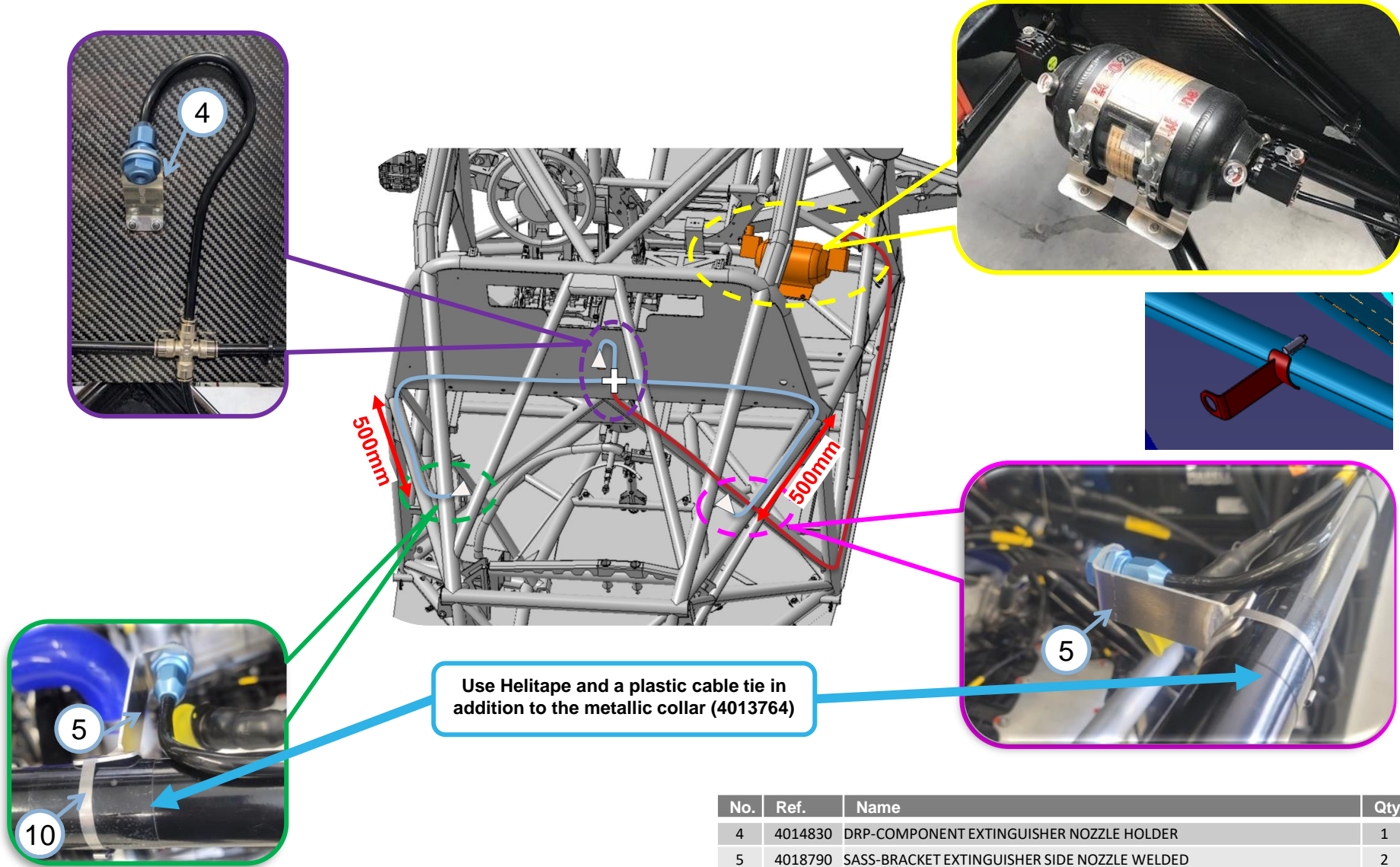

Use Helitape and a plastic cable tie in addition to the metallic collar (4013764)

No.	Ref.	Name	Qty.
4	4014830	DRP-COMPONENT EXTINGUISHER NOZZLE HOLDER	1
5	4018790	SASS-BRACKET EXTINGUISHER SIDE NOZZLE WELDED	2
10	4013764	COP-TO BE DEFINED COLLIERES DE SERRAGE INOX A BILLE	2

### 3.4.3.1 RIGIDE LINES – Fire Extinguisher Kit – Circuit details

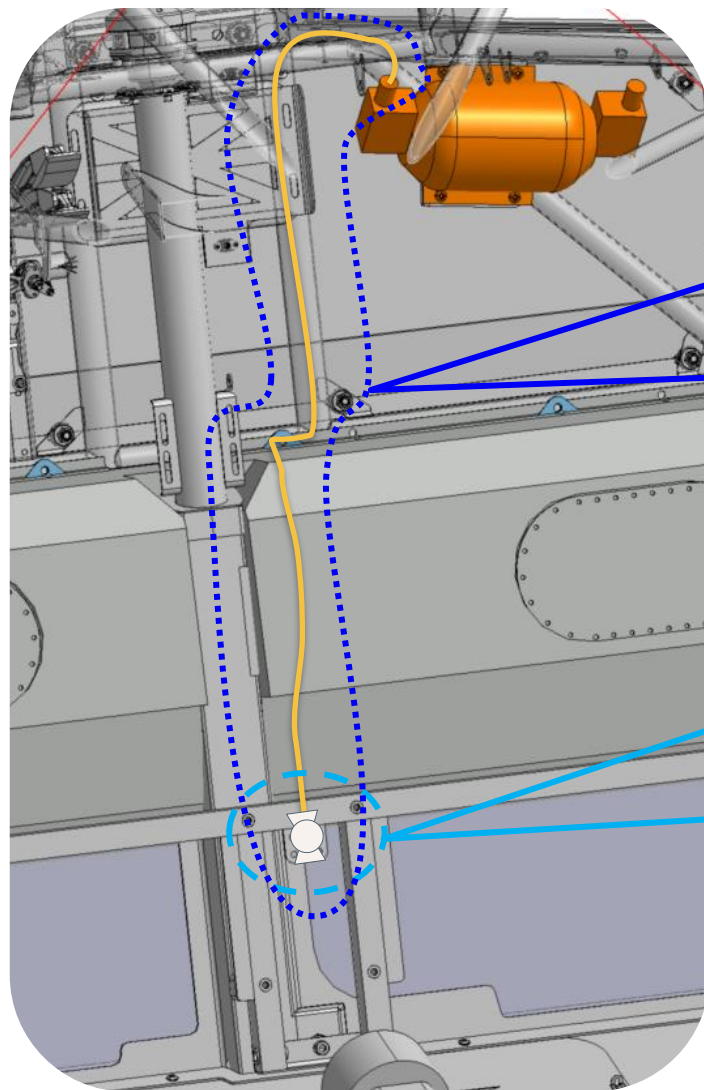

To install after setup  
the whole cockpit

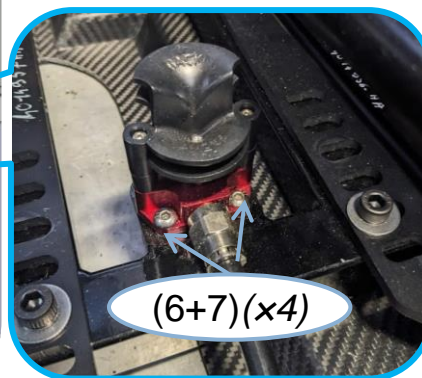
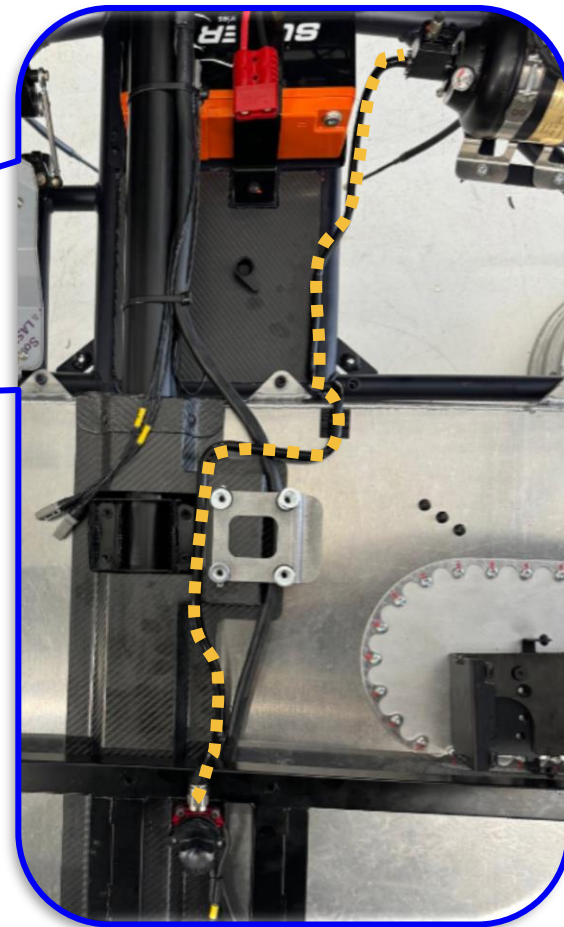

No.	Ref.	Name	Qty.
6	4013851	COP-SCREW VIS A EMBASE TETE BASSE M5X12	4
7	4012820	COP-INSERT TAPPED – M5	4

### 3.4.3.2 RIGIDE LINES – Fire Extinguisher Kit – Circuit details

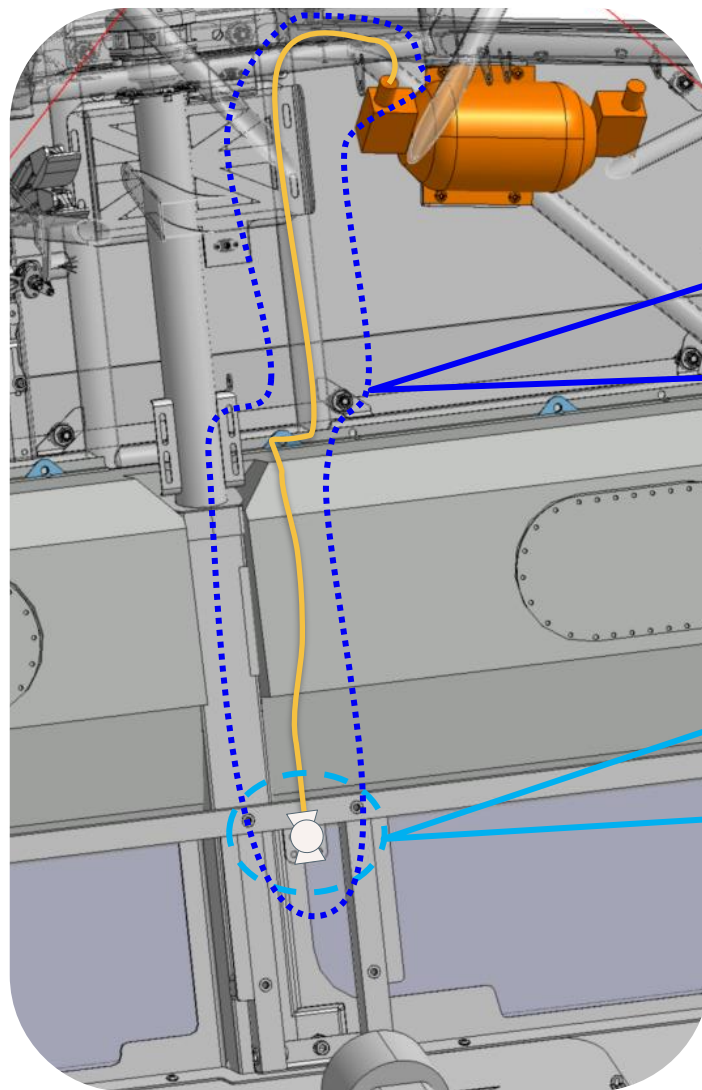

To install after setup the whole cockpit

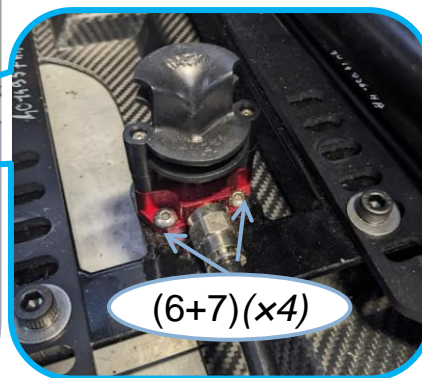
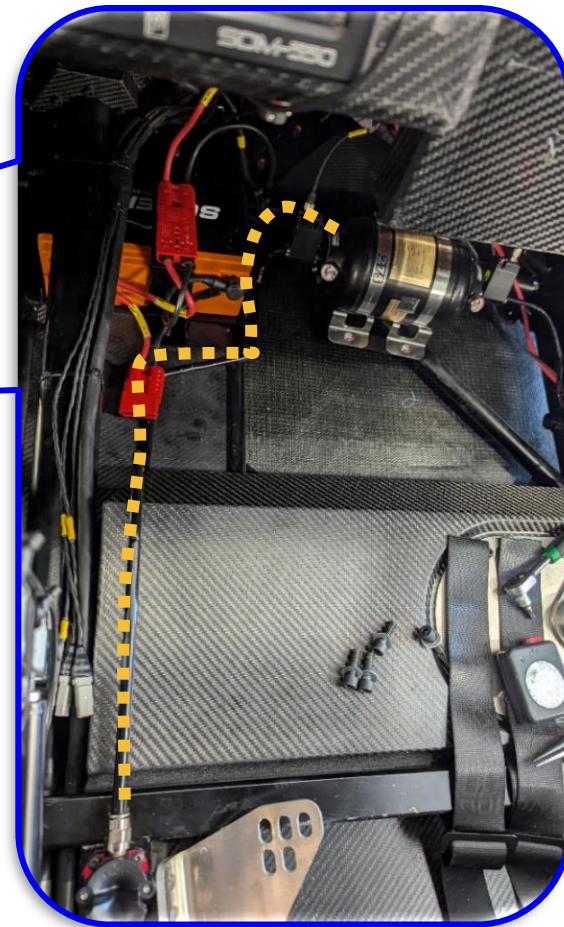

(6+7)(x4)

No.	Ref.	Name	Qty.
6	4013851	COP-SCREW VIS A EMBASE TETE BASSE M5X12	4
7	4012820	COP-INSERT TAPPED – M5	4

# 3.5 PEDALBOX – Overview

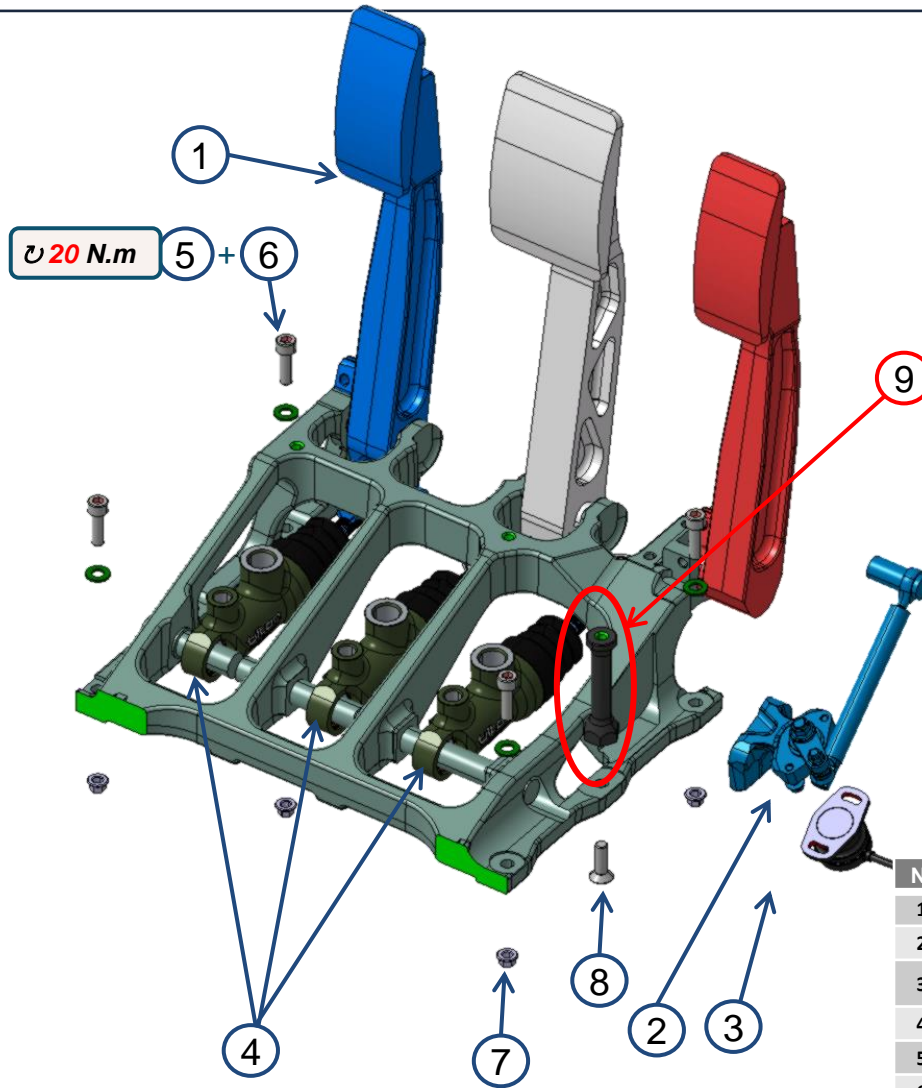

**9** This part is to pickup in the kit "4018350"

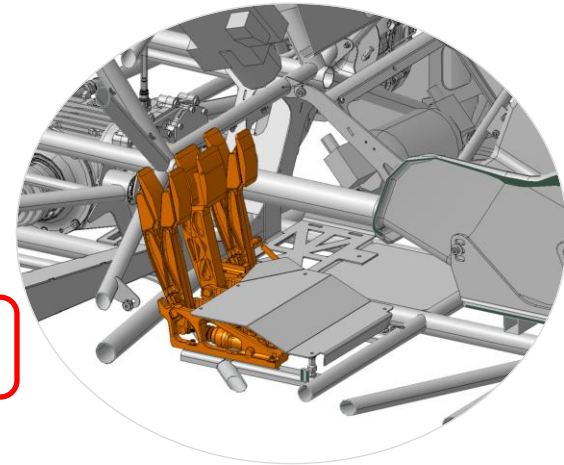

No.	Ref.	Name	Qty.
1	4015159	DRP-COMPONENT TILTON PEDAL BOX 72-856 REWORKED	1
2	4014041	COP-TILTON TROTTLER LINKAGE SYSTEM 72-794	1
3	4014725	DRP-WIRING HARNESS, ACCELERATOR PEDAL TILTON	1
4	4012927	COP-MASTER CYLINDER 78-875 Ø22.23	3
5	4000936	SUP-HEXAGONAL SOCKET CAP SCREW ISO 4762 M6X20-20 P100 CL12.9 A B	4
6	4009150	SUP-PLAIN WASHER D6XD12X1.2 TYPE Z NFE25-514 A EZ	4
7	4013685	COP-NUT M6X100 SIMMONDS	4
8	4003391	SUP-HEXAGON SOCKET COUNTERSUNK HEAD CAP SCREW M6X20-13.5 P100 CL10.9	1
9	4014100	COP-TILTON FALSE FLOOR KIT 72-853-FF	

### 3.5.3 PEDALBOX– Setup : accelerator pedal

#### Accelerator pedal setup

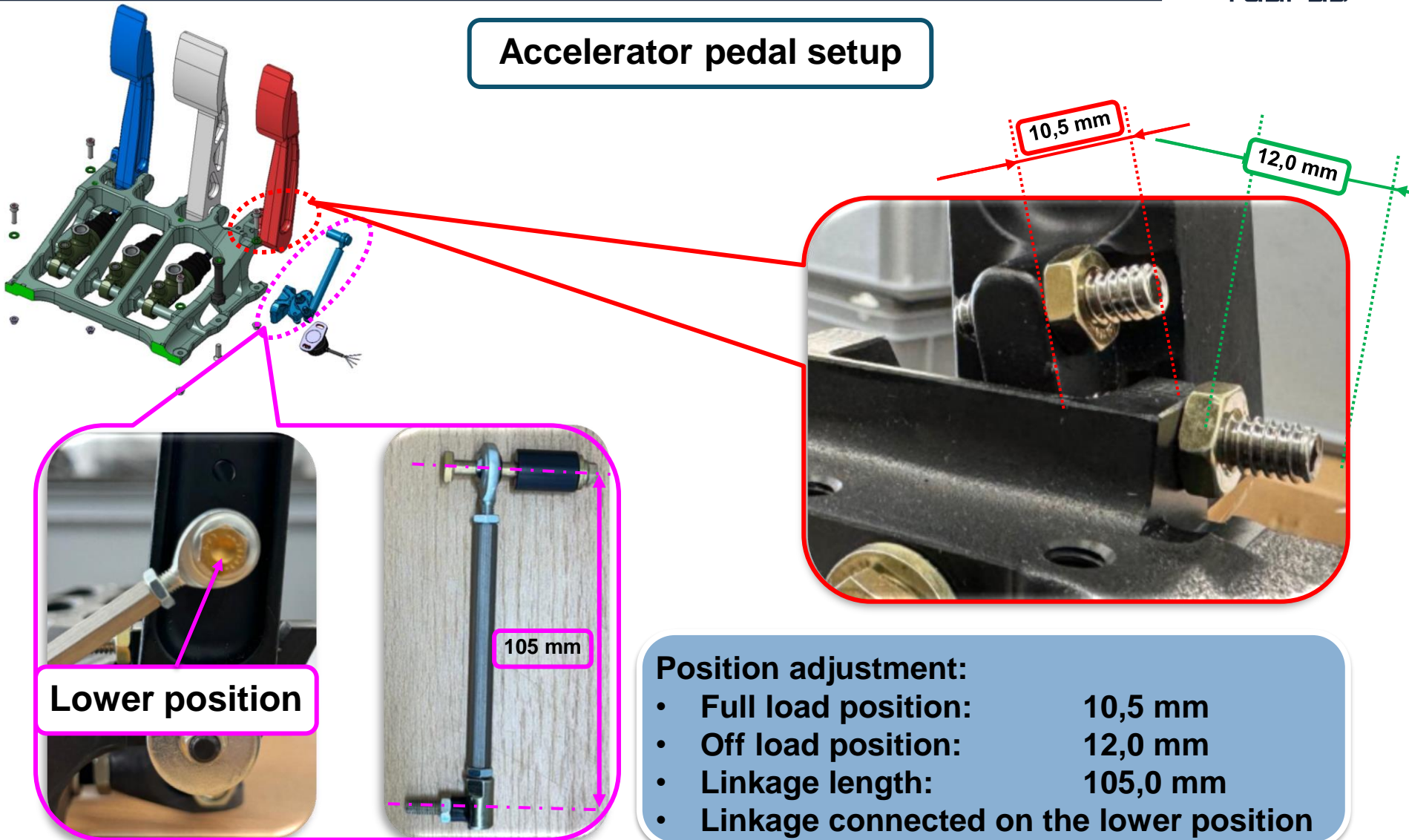

#### Position adjustment:

- Full load position: 10,5 mm
- Off load position: 12,0 mm
- Linkage length: 105,0 mm
- Linkage connected on the lower position

- **The 2 master cylinders must be assembled with a gap of 20 mm from brake pedal**

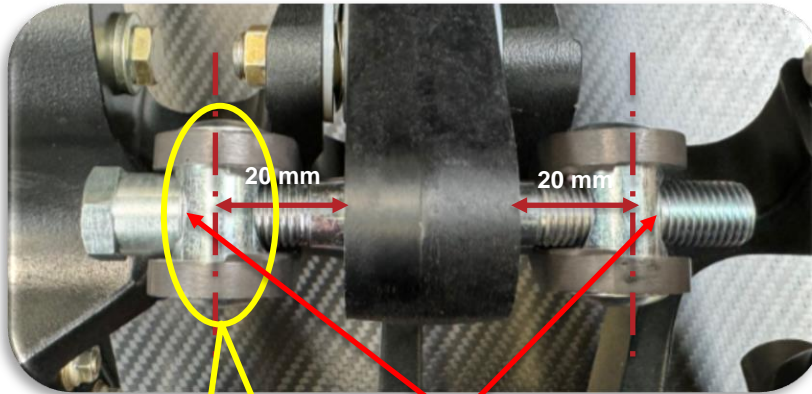

The machined face must be visible from the side

The machined face must be in contact with the locking nut. To warranty the stability of the brake balance



## 3.5.5 PEDALBOX– Clutch Pedal Stroke Setup

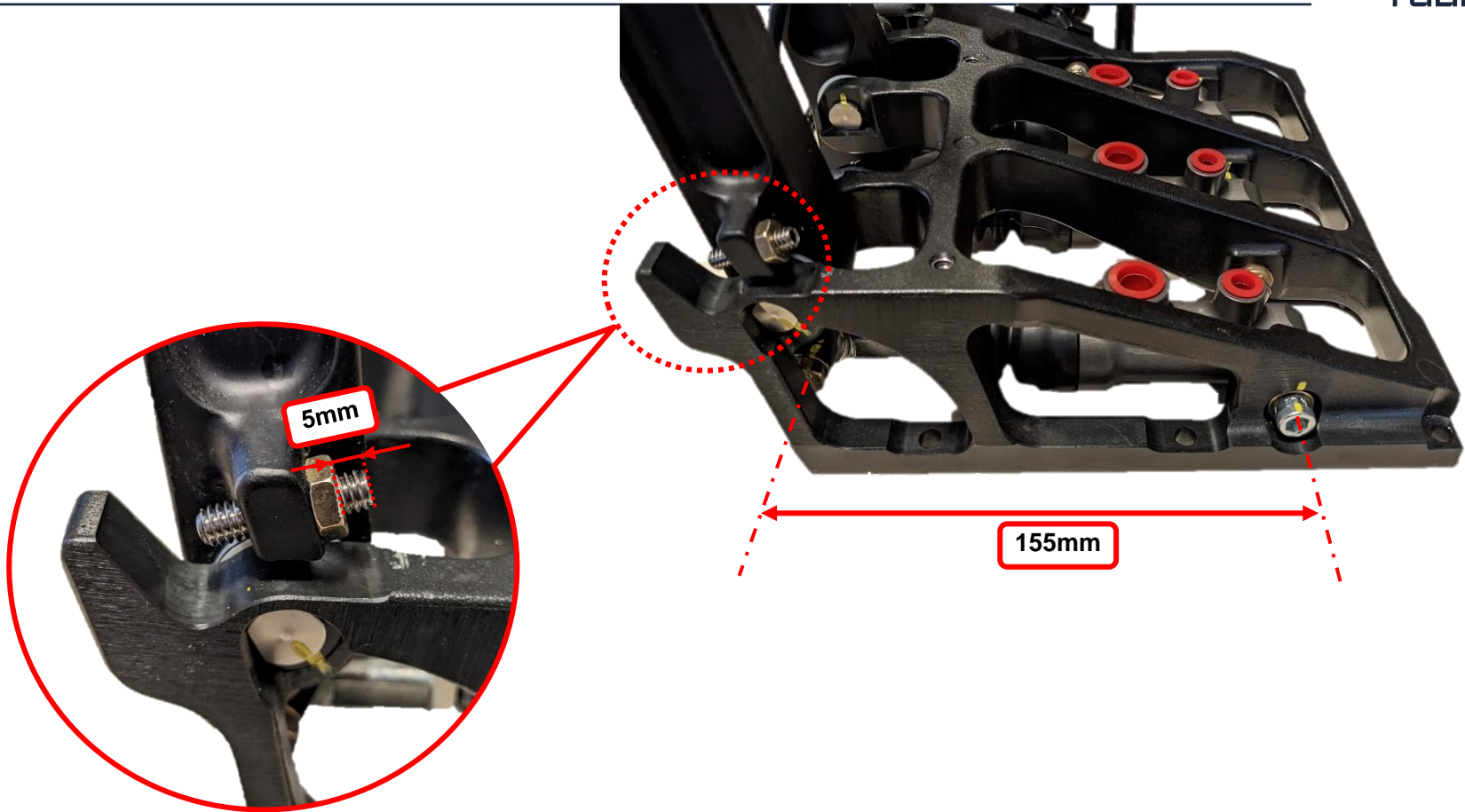

**Clutch pedal setup**

### 3.5.7 PEDALBOX – Brake and Clutch Fluid Tanks

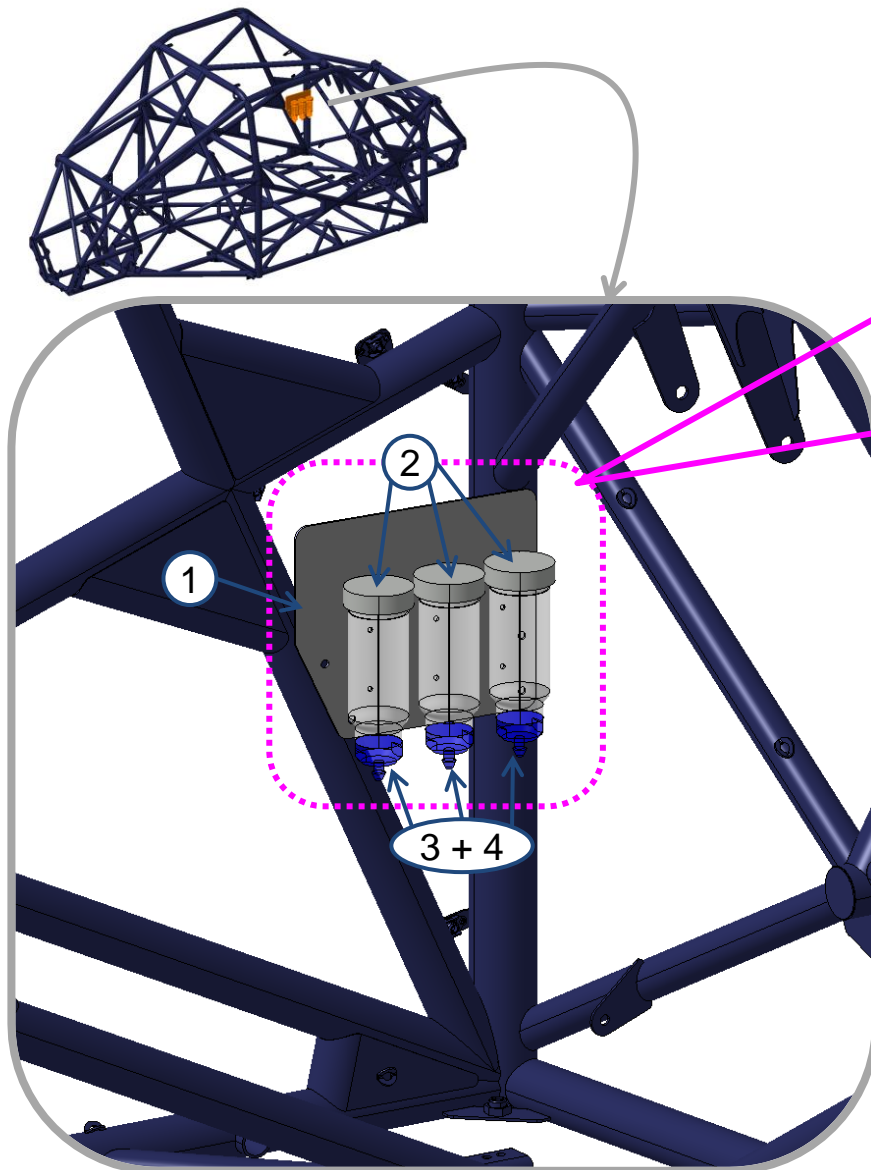

Secure the carbon plate to the chassis with zip ties

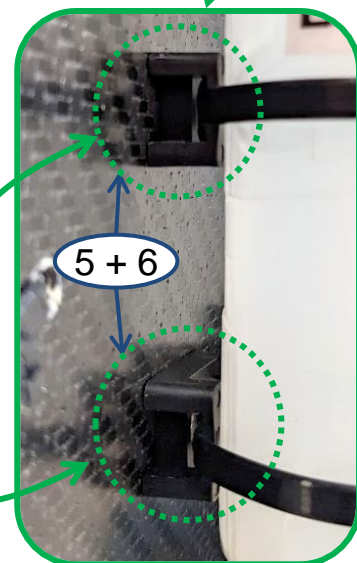

Tanks must be secured to the plate using zip ties and zip tie mounts riveted to the plate

No.	Ref.	Name	Qty.
1	4016593	DRP-BRACKET 3 TANKS AP RACING	1
2	4014789	COP-TANK FOR MASTERCYLINDER BRAKE CP470911 AP RACING	3
3	4014792	COP-ADAPTER FOR TANK CP4709	3
4	4014793	COP-RING O RING CP4709104 AP RACING	3
5	4013573	COP-TO BE DEFINED EMBASE DE COLLIER A VISSER	6
6	4013908	COP-TO BE DEFINED RIVETS ALUMINIUM Ø4x10MM	6



### 3.5.9 PEDALBOX – Tubing

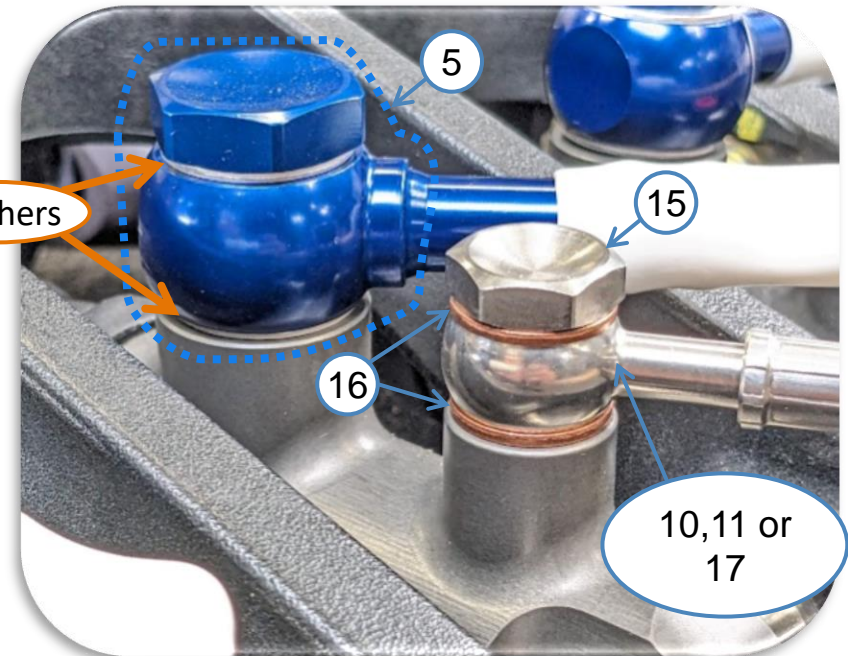
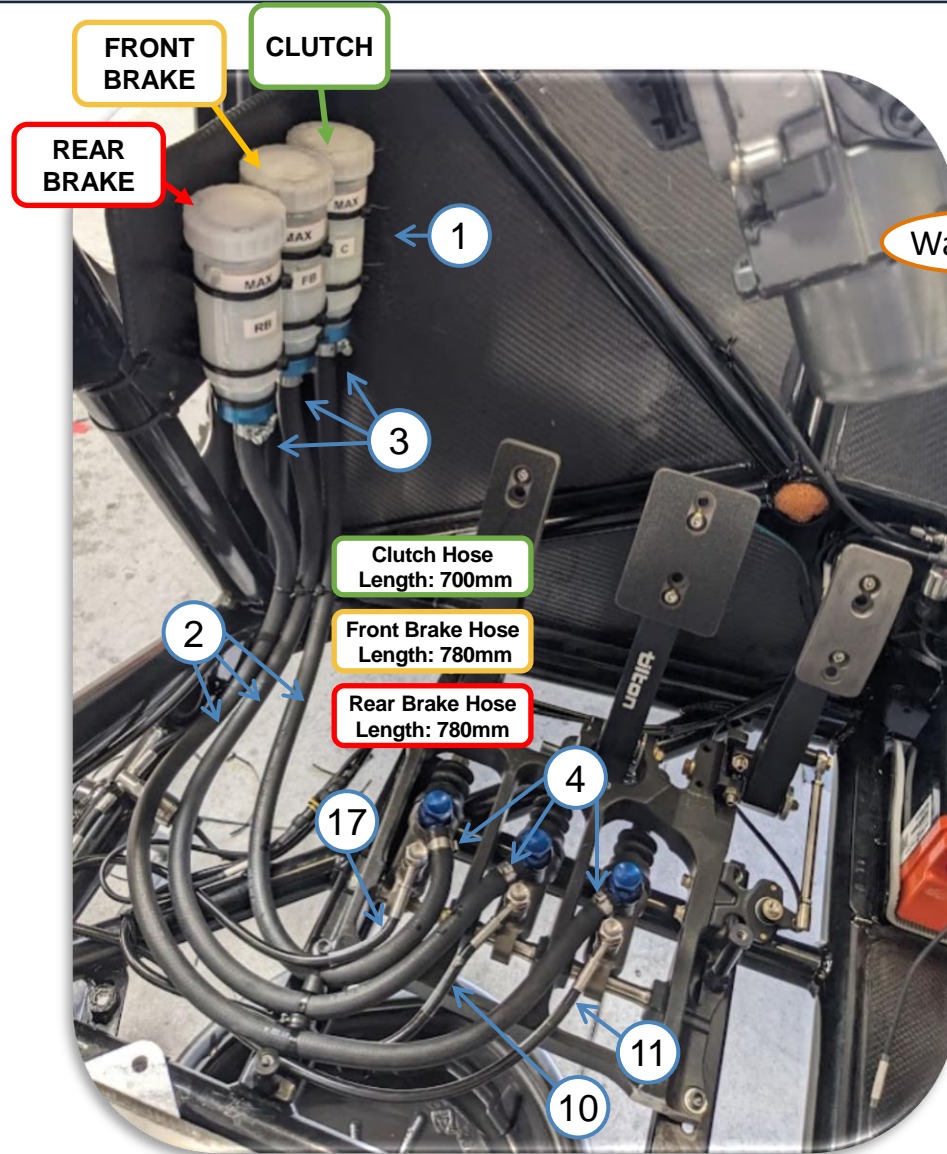

No.	Number	Name	Qty.
1	4016711	SASS-TO BE DEFINED BRAKES AND CLUTCH TANKS	1
2	4012586	COP-HOSE KIT FOR TANK - 5/16 ID - L96INCHES – TILTON	1
3	4013742	COP-TO BE DEFINED COLLIERES DE SERRAGE TYPE NORMA Ø12.5-Ø14.5	3
4	4013740	COP-TO BE DEFINED MABEO COLLIER DE SERRAGE A 1 OREILLE LARGEUR 8.2 À 9.2MM Ø12.2À Ø15.8MM	3
5	4016531	COP-TO BE DEFINED SASS VIS BANJO+BANJO+ JOINTS X118-14D+FPB91-14M10D+AWM14	3
10	4016500	COP-HOSE FRONT BRAKE FROM MASTER CYLINDER TO WALL PASS LG: 1180+205MM	1
11	4016501	COP-HOSE FLEX 15 REAR BRAKE FROM MASTER CYLINDER TO START OF RIGID BRAKE LINE LG:1000	1
15	4013245	COP-SCREW BANJO 3/8-24 JIC	3
16	4013244	COP-WASHER BANJO Ø10	6
17	4016497	COP-HOSE CLUTCH TO MASTER CYLINDER LG: 360MM	1

## Section 4

### FUEL CELL

## 4.1.1 FUEL STORAGE – Fuel Tank – Overview

### Aluminum fuel tank

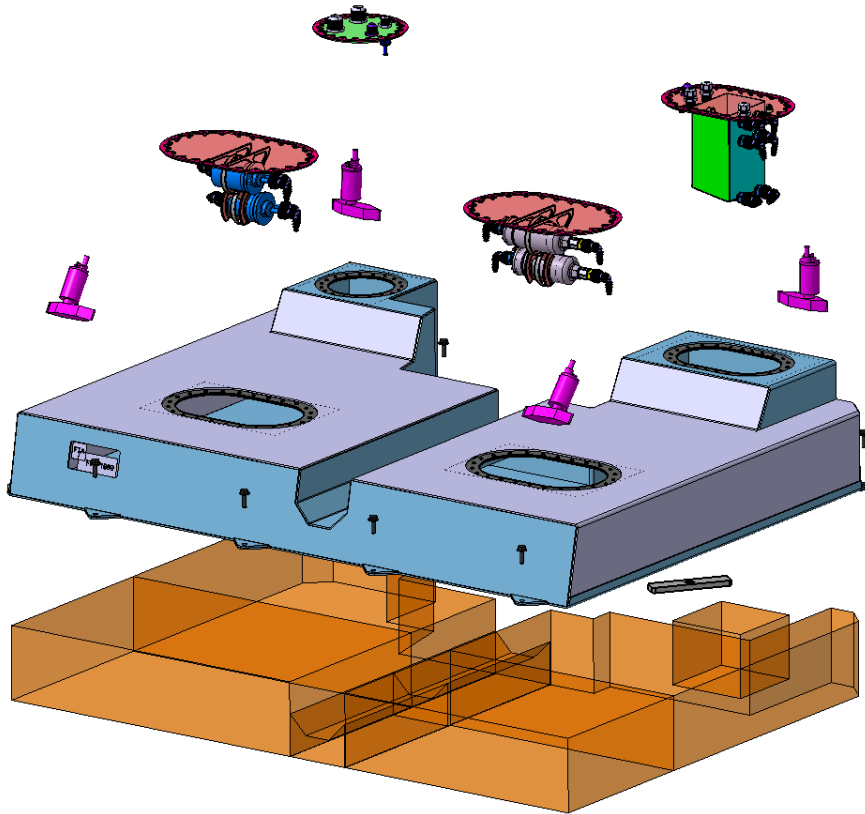

No.	Ref.	Name	Qty.
1	4014388	MCE-COP-TANK CAISSON RESERVOIR CTX BOITE TAMPON IMMERGEE	1
2	4014865	MCE-ASS-COMPONENT FUEL BUFFER BOX 1.5L - EQUIPPED	1
3	4014881	MCE-SASS-COMPONENT FUEL CELL COVER BRACKET - WELDED	2
4	4012410	MCE-SUP-FILTER A ESSENCE	2
5	4021811	MCE-DRP-ADAPTER QUICK CONNECTOR MALE	2
6	4018625	MCE-DRP-ADAPTER QUICK CONNECTOR MALE	2
7	4018094	MCE-SUP-CONNECTOR QUICK FIT COUDE 90°	17
8	4014892	MCE-ASS-COMPONENT FUEL CELL COVER / FUEL EXIT – EQUIPPED	1
9	4017609	MCE-COP-CONNECTOR RACCORD UNION JIC	1
10	4018122	MCE-COP-CONNECTOR Y	2
11	4018760	MCE-SUP-HOSE CLAMP	32
12	4014969	MCE-DRP-TO BE DEFINED WEDGE-UNDER FUEL TANK	2
13	4017007	MCE-COP-SCREW	10
14	2003775	DFM-COP-SUPPLY SC HOSE CLAMP	4
15	4017580	MCE-COP-HOSE LIFT FUEL PUMP 3	1
16	4017579	MCE-COP-HOSE LIFT FUEL PUMP 4	1
17	4017581	MCE-COP-HOSE LIFT FUEL PUMP 2	1
18	4017582	MCE-COP-HOSE LIFT FUEL PUMP 1	1
19	4017731	MCE-COP-HOSE BOITE TAMPON – PBP	2
20	4017589	MCE-COP-HOSE PBP - REG+ FILTRE	2
21	4017590	MCE-COP-HOSE REG+FILTRE - RACCORD TEE	6
22	4017732	MCE-COP-HOSE RACCORD TEE – RAMP	1
23	4017592	MCE-COP-HOSE RACCORD TEE- BOITE TAMPON	1
24	4018769	MCE-SASS-WIRING LIFT FUEL PUMPS 3 & 4 - 2023+	1
25	4018768	MCE-SASS-WIRING LIFT FUEL PUMPS 1 & 2 - 2023+	1
26	4013037	MCE-SASS-WIRING HP FUEL PUMPS	1
27	4017932	MCE-DRP-COMPONENT FUEL CELL PLATE /FUEL EXIT	1
28	4017933	MCE-DRP-COMPONENT TOP PLATE - FUEL BUFFER BOX 1.5L	1
29	4017934	MCE-DRP-COMPONENT FUEL CELL PLATE	2
30	4018797	MCE-SUP-TO BE DEFINED FUEL CELL FOAM KIT	1
31	4013035	MCE-DRP-WIRING HARNESS FEEDING PUMPS	1
32	4014890	MCE-DRP-HARNESS EXTENSION FROM ECU HARNESS TO HP FUEL PUMP HARNESS	1
33	4016807	MCE-COP-SCREW TBHC	43
34	4016808	MCE-COP-SCREW	48
35	4018817	MCE-COP-ADAPTER	2
36	4014775	MCE-COP-SEAL COPPER WASHER	2
37	4014876	MCE-COP-TO BE DEFINED COPPER GASKET	2
38	4014875	MCE-COP-TO BE DEFINED COPPER GASKET	2
39	4018662	MCE-COP-TO BE DEFINED CHECK VALVE	2
40	4014322	MCE-SUP-LOCKNUT WITH FLANGE	2

## 4.1.2 FUEL STORAGE – Fuel Tank – Fixing To Chassis

Aluminum fuel tank

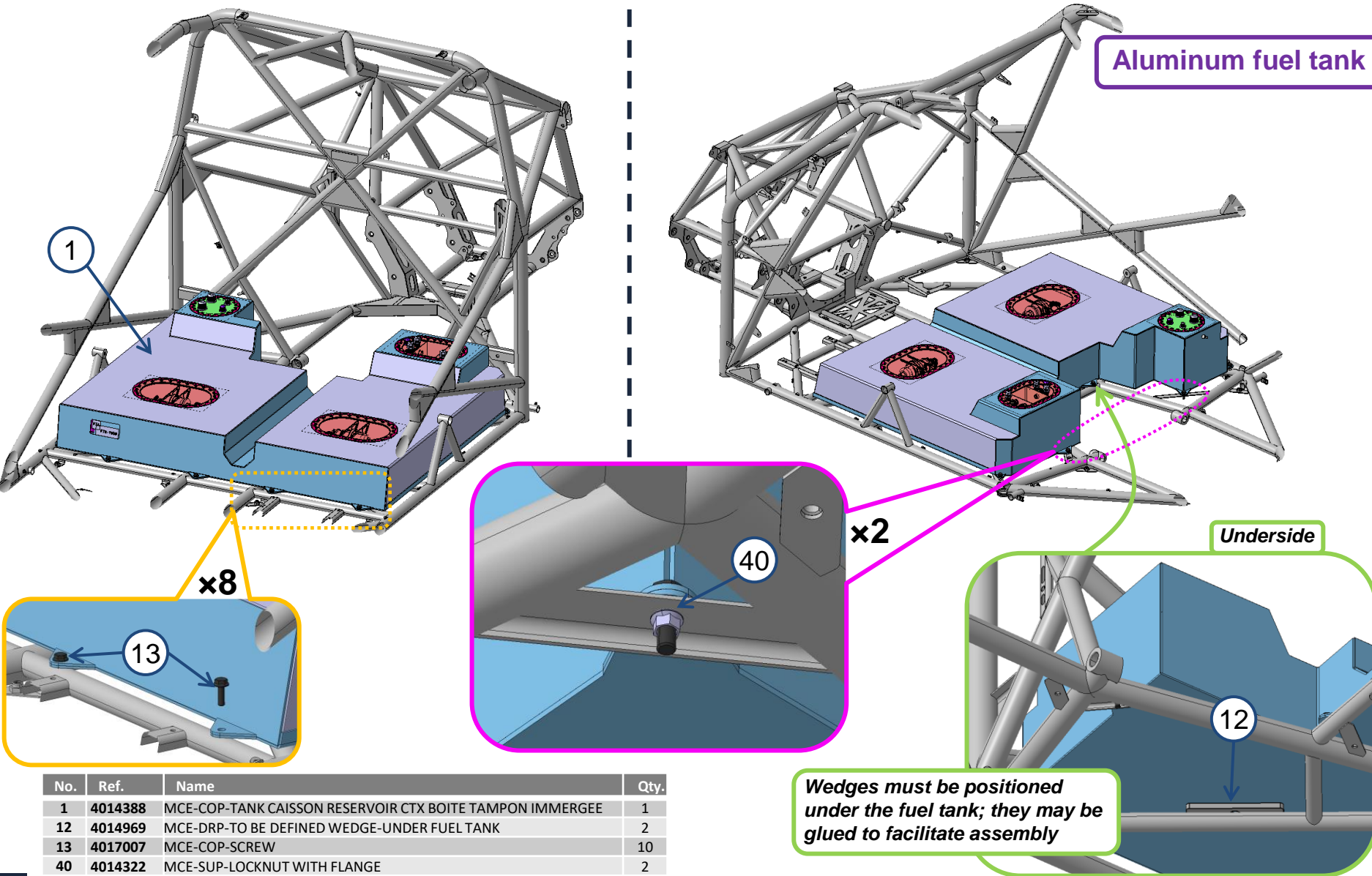

No.	Ref.	Name	Qty.
1	4014388	MCE-COP-TANK CAISSON RESERVOIR CTX BOITE TAMPON IMMERGEE	1
12	4014969	MCE-DRP-TO BE DEFINED WEDGE-UNDER FUEL TANK	2
13	4017007	MCE-COP-SCREW	10
40	4014322	MCE-SUP-LOCKNUT WITH FLANGE	2

## 4.1.3 FUEL STORAGE – Fuel Tank – Fuel Buffer Box Equipped

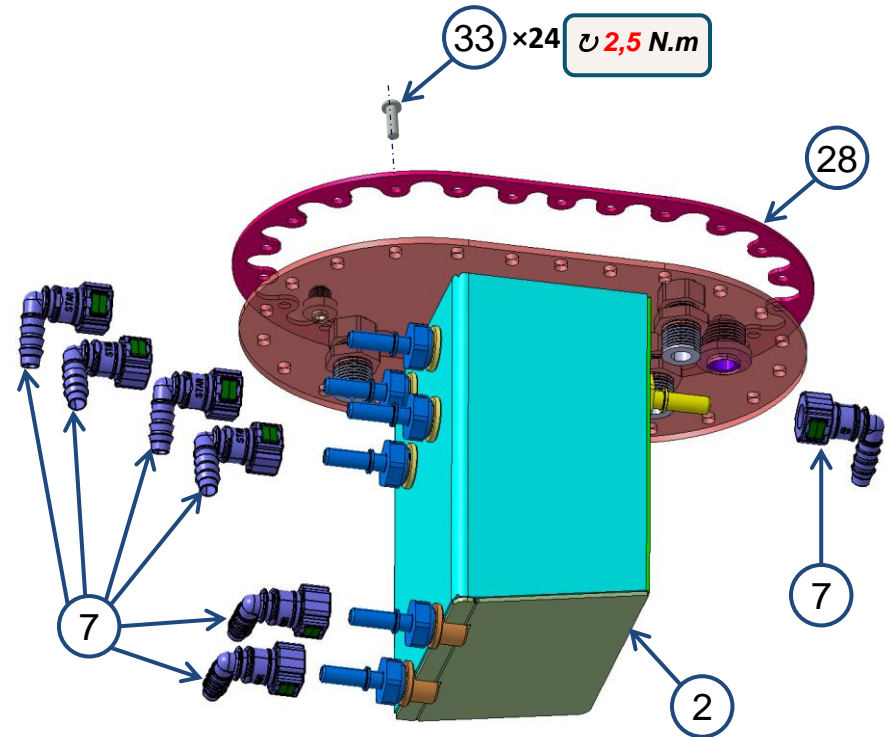
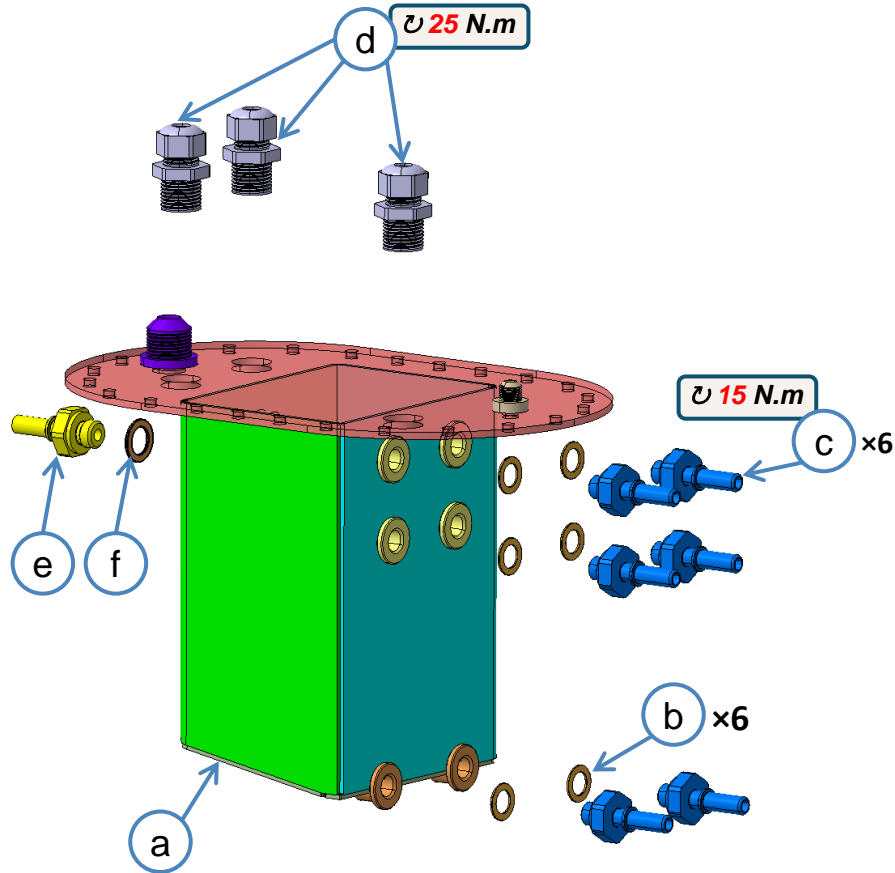

No.	Ref.	Name	Qty.
-	4014865	ASS - COMPONENT FUEL BUFFER BOX 1.5L – EQUIPPED	1
a	4014866	SASS - COMPONENT FUEL BUFFER BOX 1.5L – WELDED	1
b	4014875	COP - COPPER GASKET	6
c	4018625	COP - ADAPTER QUICK CONNECTOR MALE	6
d	4014108	COP - STUFFING-BOX - FUEL TANK	3
e	4015029	COP - ADAPTER QUICK CONNECTOR MALE	1
f	4014775	COP - SEAL COPPER WASHER	1

No.	Ref.	Name	Qty.
2	4014865	ASS - COMPONENT FUEL BUFFER BOX 1.5L – EQUIPPED	1
7	4018094	MCE-SUP-CONNECTOR QUICK FIT COUDE 90°	7
28	4017933	MCE-DRP-COMPONENT TOP PLATE - FUEL BUFFER BOX 1.5L	1
33	4016807	MCE-COP-SCREW	24

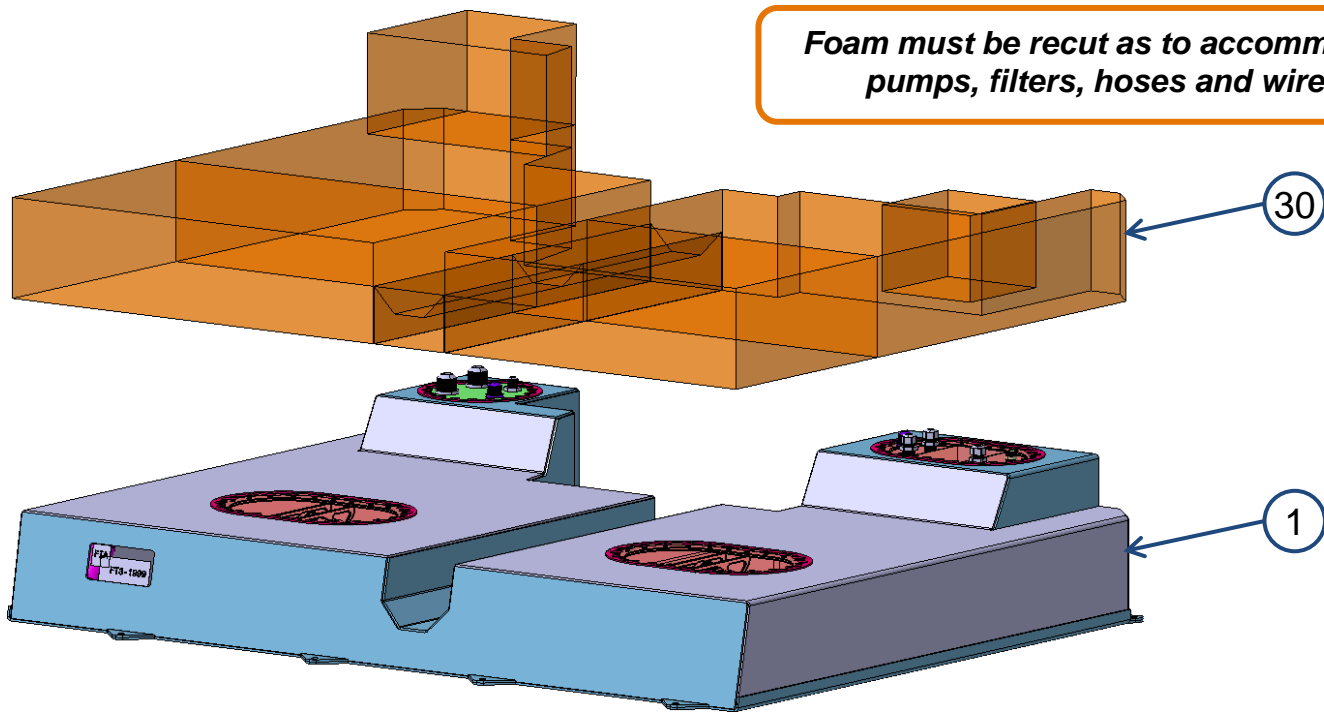

No.	Ref.	Name	Qty.
1	4014388	MCE-COP-TANK CAISSON RESERVOIR CTX BOITE TAMPON IMMERGEE	1
30	4018797	MCE-SUP-TO BE DEFINED FUEL CELL FOAM KIT	1

## 4.1.5 FUEL STORAGE – Fuel Tank – Pumps

### Aluminum fuel tank

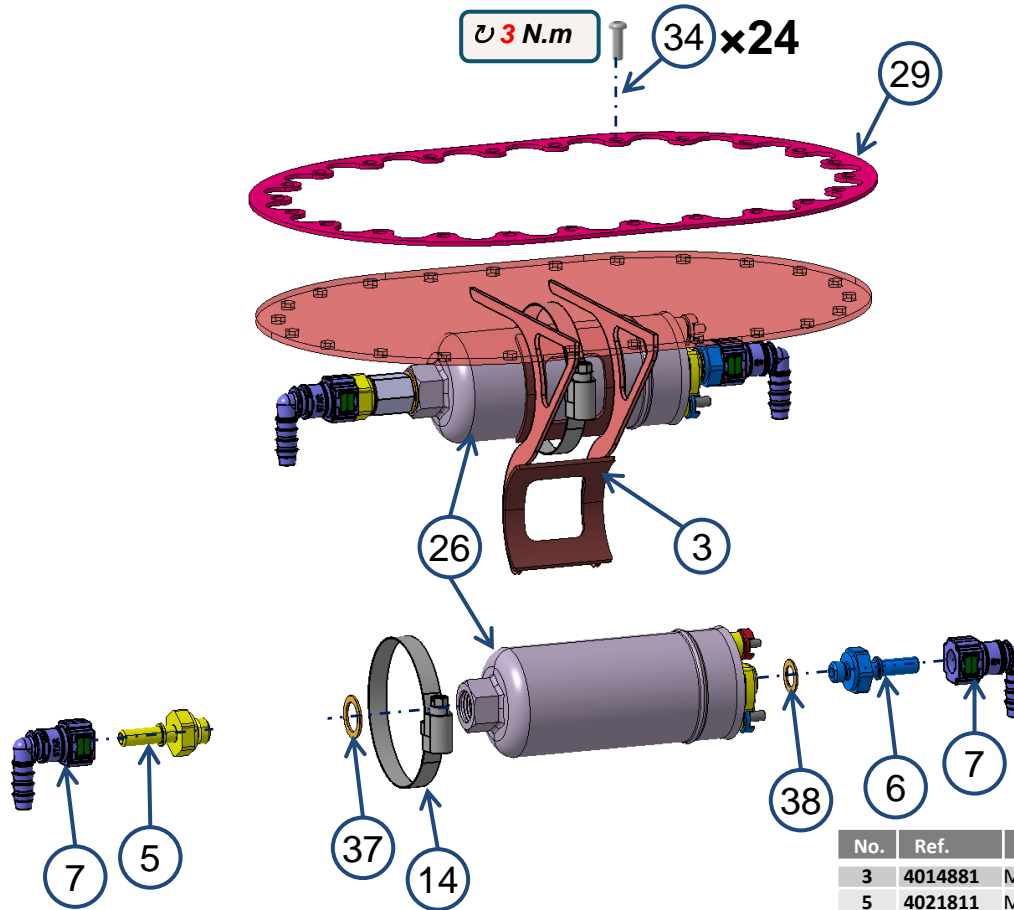

No.	Ref.	Name	Qty.
3	4014881	MCE-SASS-COMPONENT FUEL CELL COVER BRACKET – WELDED	1
5	4021811	MCE-DRP-ADAPTER QUICK CONNECTOR MALE	2
6	4018625	MCE-DRP-ADAPTER QUICK CONNECTOR MALE	2
7	4018094	MCE-SUP-CONNECTOR QUICK FIT COUDE 90°,	4
14	2003775	DFM-COP-SUPPLY SC HOSE CLAMP	2
26	4013037	MCE-SASS-WIRING HP FUEL PUMPS	1
29	4017934	MCE-DRP-COMPONENT FUEL CELL PLATE	1
34	4016808	MCE-COP-SCREW VIS TBHC	24
37	4014876	MCE-COP-TO BE DEFINED COPPER GASKET	2
38	4014875	MCE-COP-TO BE DEFINED COPPER GASKET	2

## 4.1.6 FUEL STORAGE – Fuel Tank – Filters And Fuel Exit

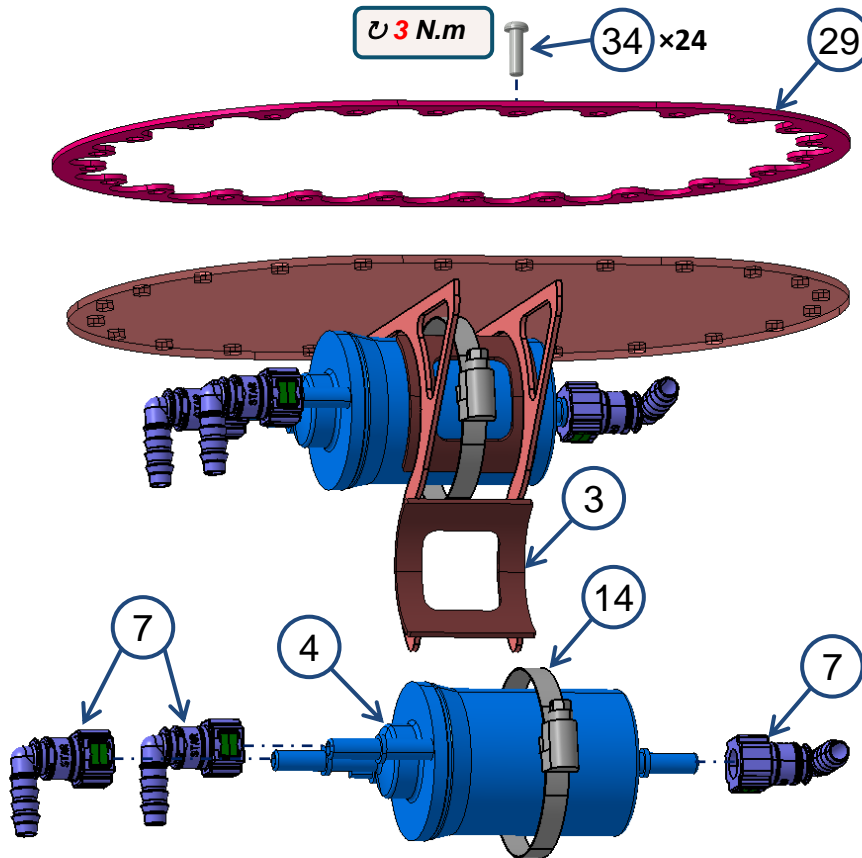

No.	Ref.	Name	Qty.
3	4014881	MCE-SASS-COMPONENT FUEL CELL COVER BRACKET - WELDED	1
4	4012410	MCE-SUP-FILTER	2
7	4018094	MCE-SUP-CONNECTOR QUICK FIT COUDE 90°	6
14	2003775	DFM-COP-SUPPLY SC HOSE CLAMP	2
29	4017934	MCE-DRP-COMPONENT FUEL CELL PLATE	1
34	4016808	MCE-COP-SCREW VIS TBHC	24

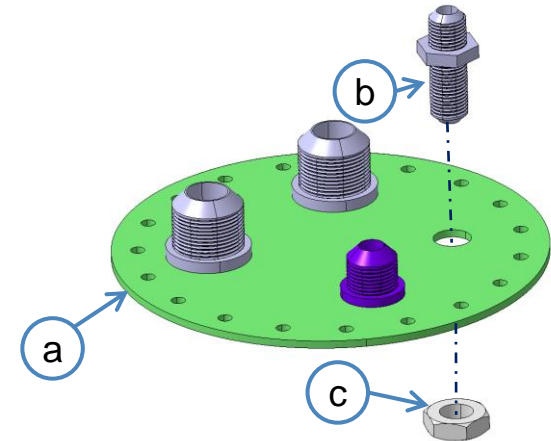

No.	Ref.	Name	Qty.
a	4014893	SASS-COMPONENT FUEL CELL COVER / FUEL EXIT – WELDED	1
b	4014864	COP-ADAPTER DASH 6 - BULKHEAD PASS	1
c	4014925	COP-NUT JAM HEX - ALU	1

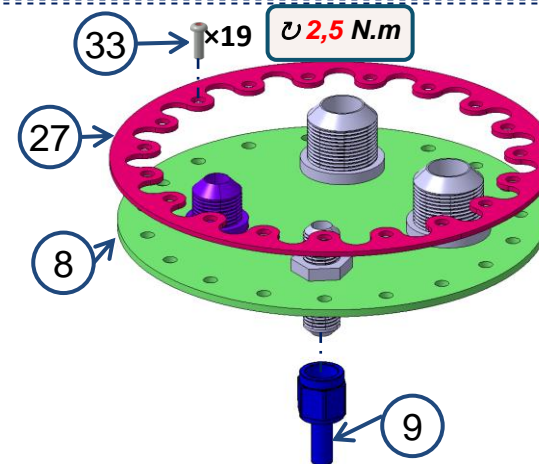

No.	Ref.	Name	Qty.
8	4014892	MCE-ASS-COMPONENT FUEL CELL COVER / FUEL EXIT - EQUIPPED	1
9	4017609	MCE-COP-CONNECTOR RACCORD UNION JIC	1
27	4017932	MCE-DRP-COMPONENT FUEL CELL PLATE /FUEL EXIT	1
33	4016807	MCE-COP-SCREW TBHC	19



# 5.1.7 FUEL STORAGE – Fuel Tank – Lift Pumps

Aluminum fuel tank

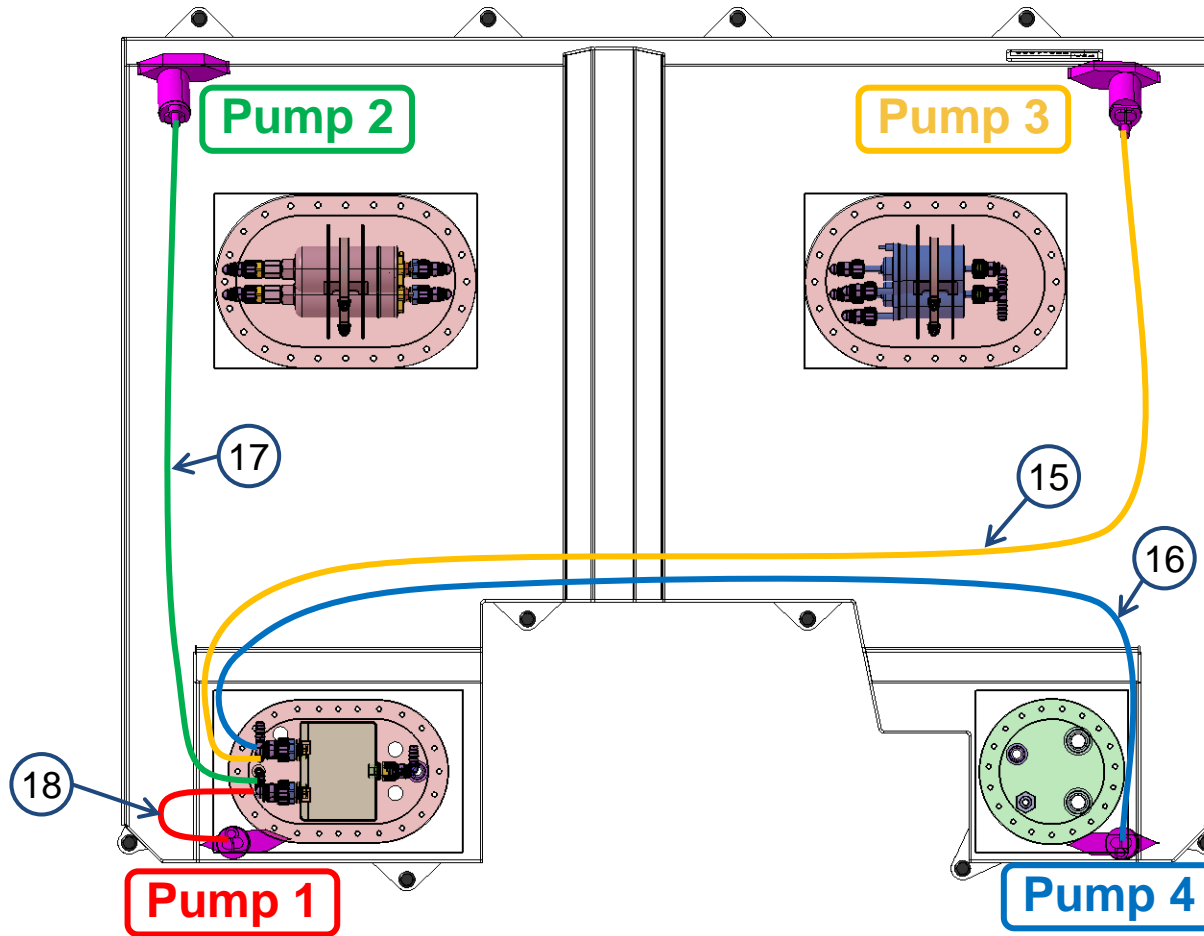

At each end of each hose use a hose clamp ⑪

No.	Ref.	Name	Qty.
11	4018760	MCE-SUP-HOSE CLAMP	8
15	4017580	MCE-COP-HOSE LIFT FUEL PUMP 3	1
16	4017579	MCE-COP-HOSE LIFT FUEL PUMP 4	1
17	4017581	MCE-COP-HOSE LIFT FUEL PUMP 2	1
18	4017582	MCE-COP-HOSE LIFT FUEL PUMP 1	1

# 4.1.8 FUEL STORAGE – Fuel Tank – Hp Pumps, Filters And Exit

Aluminum fuel tank

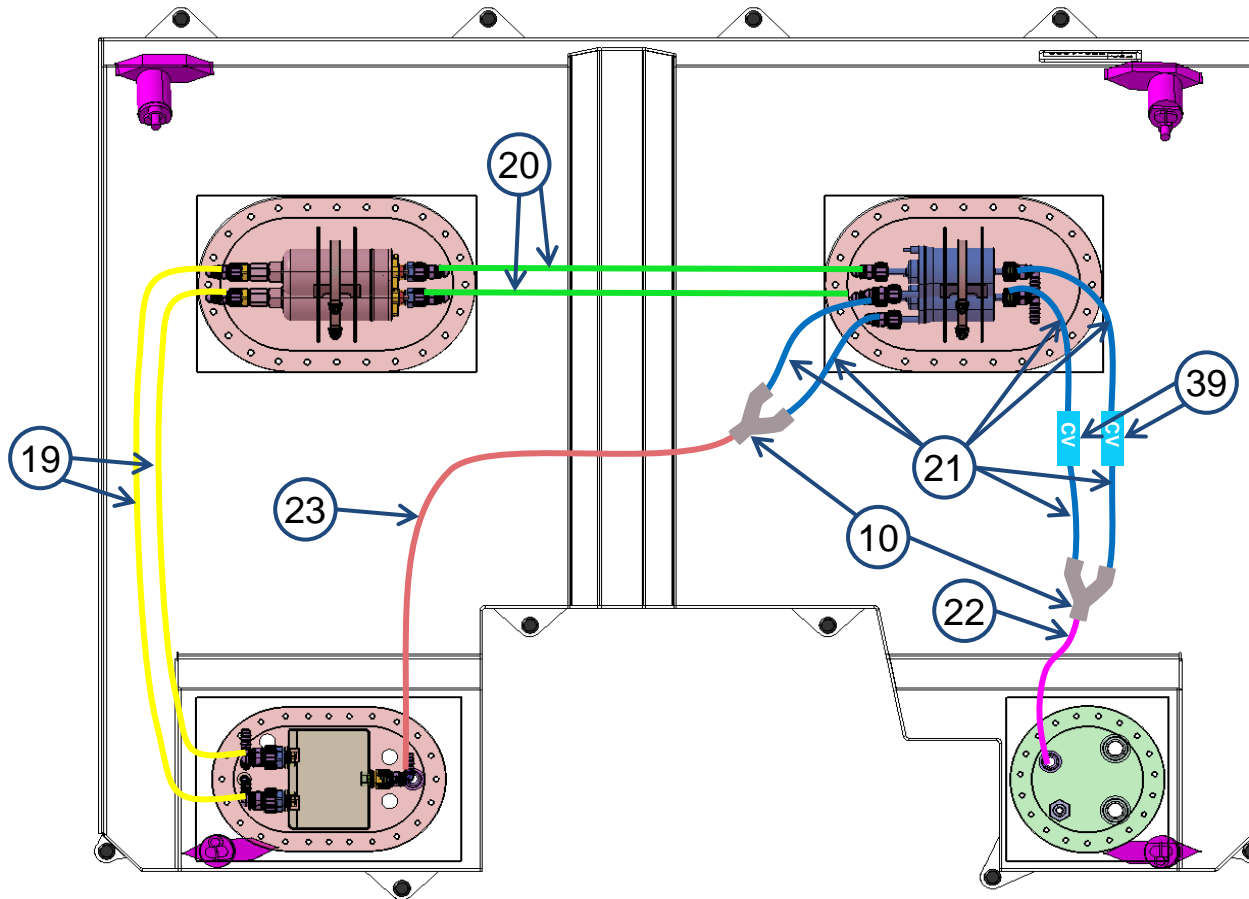

**At each end of each hose use a hose clamp (11)**

No.	Ref.	Name	Qty.
10	4018122	MCE-COP-CONNECTOR Y	2
11	4018760	MCE-SUP-HOSE CLAMP	24
19	4017751	MCE-COP-HOSE BOITE TAMPON – PBP	2
20	4017589	MCE-COP-HOSE PBP - REG+ FILTRE	2
21	4017590	MCE-COP-HOSE REG+FILTRE - RACCORD TEE	6
22	4017732	MCE-COP-HOSE RACCORD TEE – RAMP	1
23	4017592	MCE-COP-HOSE RACCORD TEE- BOITE TAMPON	1
39	4018662	MCE-COP-TO BE DEFINED CHECK VALVE	2

# 4.1.9 FUEL STORAGE – Fuel Tank – Buffer Box Connection Details

Aluminum fuel tank

Buffer box, from lift pumps and towards HP pumps

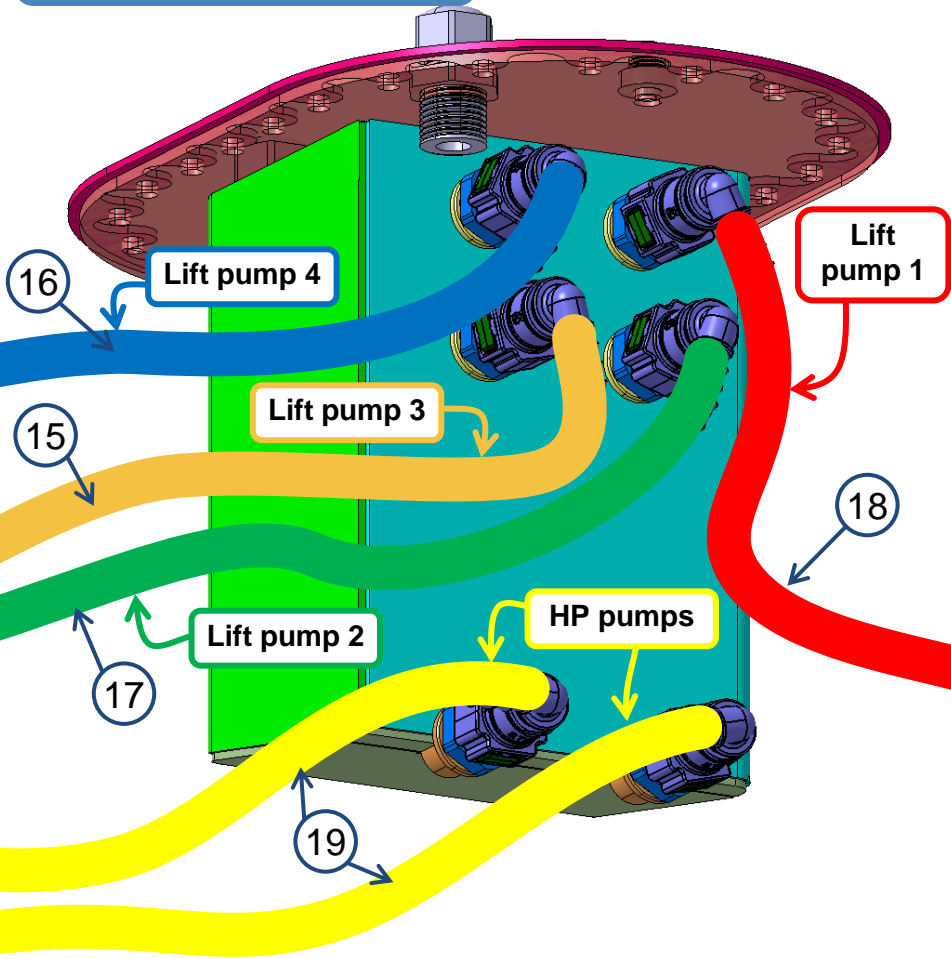

Buffer box, from filter bypass

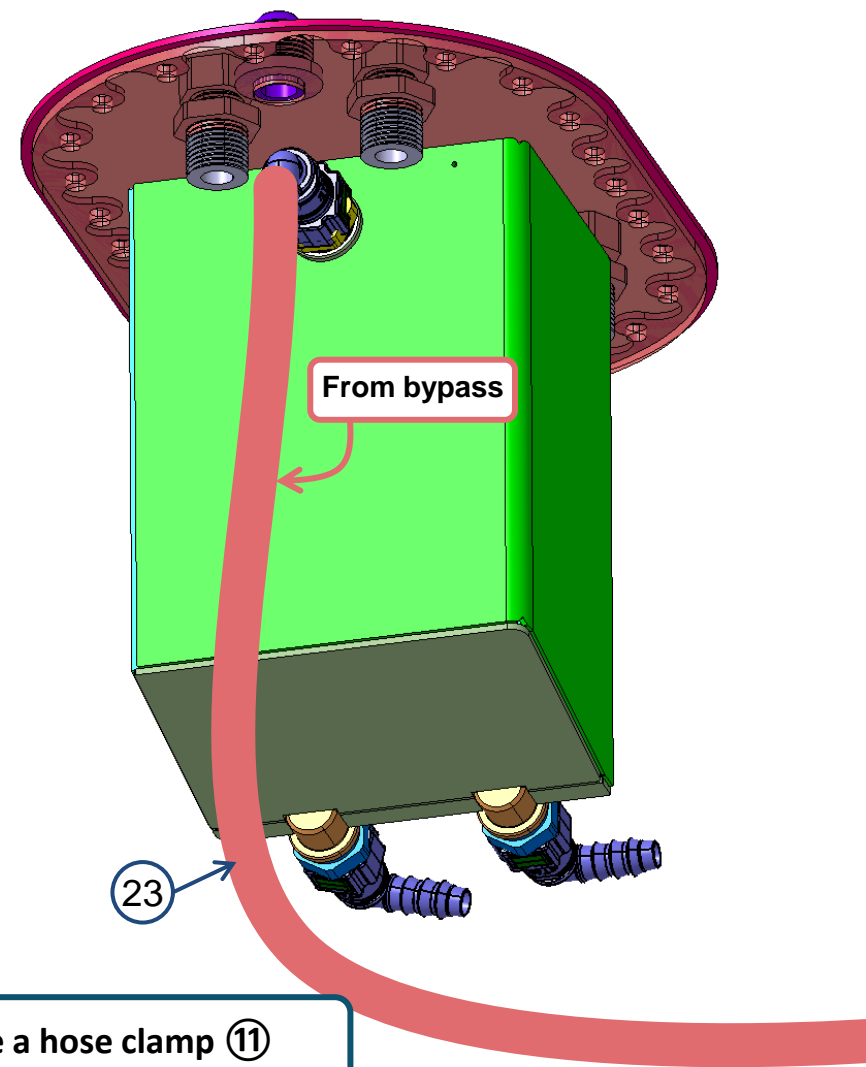

At each end of each hose use a hose clamp (11)

# 4.1.10 FUEL STORAGE – Fuel Tank – Pump And Filter Details

Aluminum fuel tank



Fuel filter

HP pumps

At each end of each hose use a hose clamp ⑪

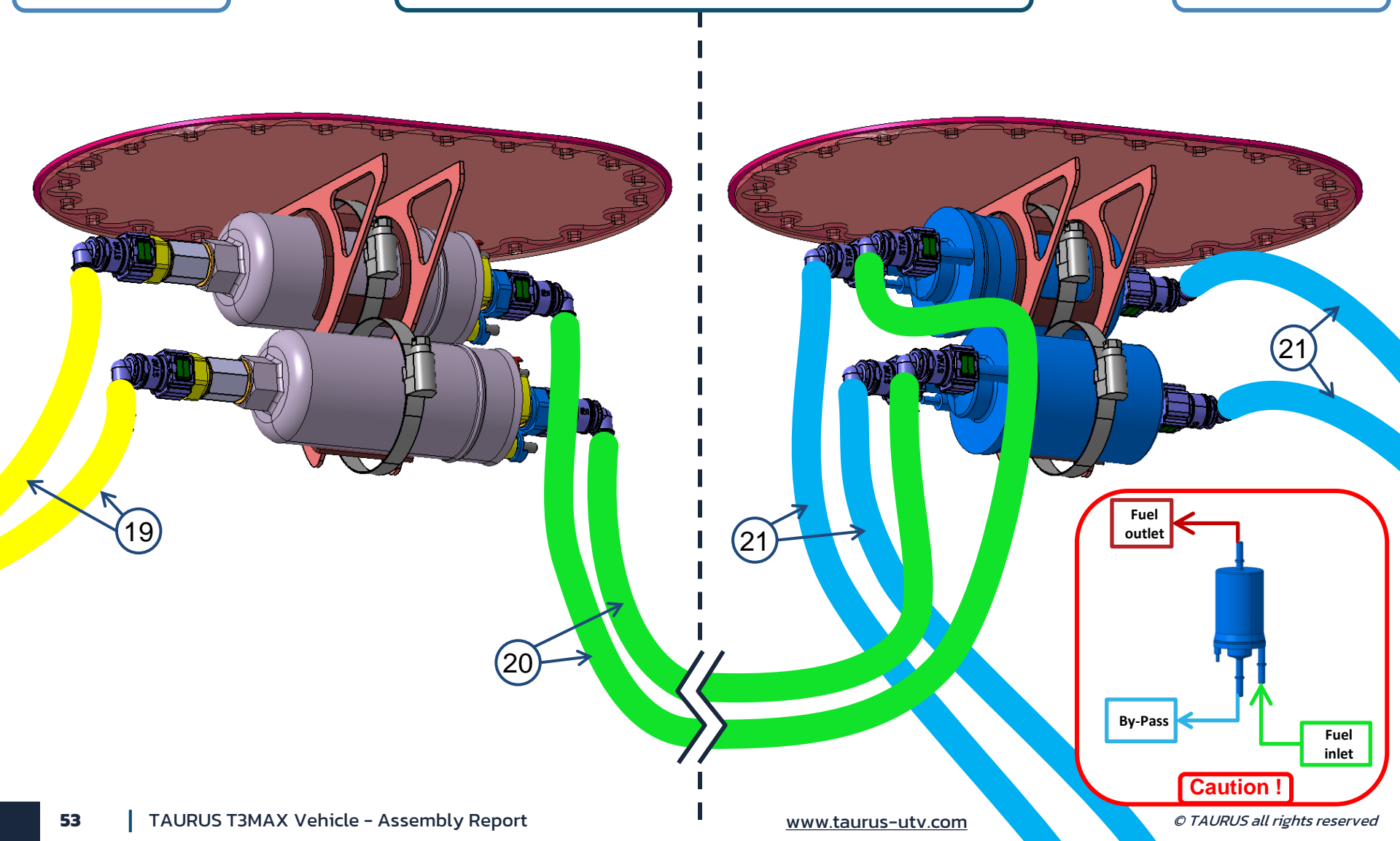

# 4.1.11 FUEL STORAGE – Fuel Tank – Exit Details

Aluminum fuel tank



At each end of each hose use a hose clamp ⑪

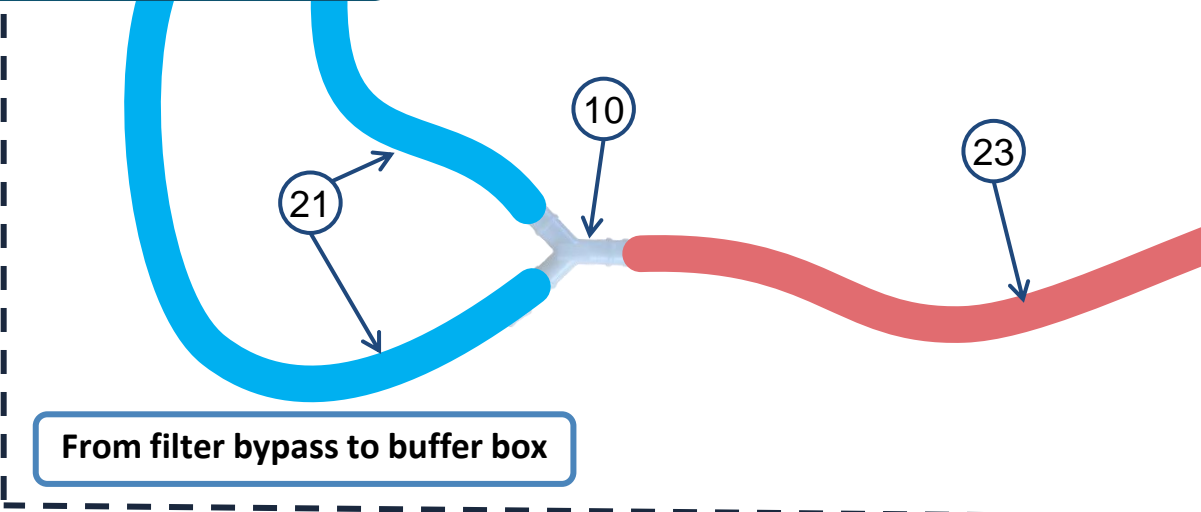
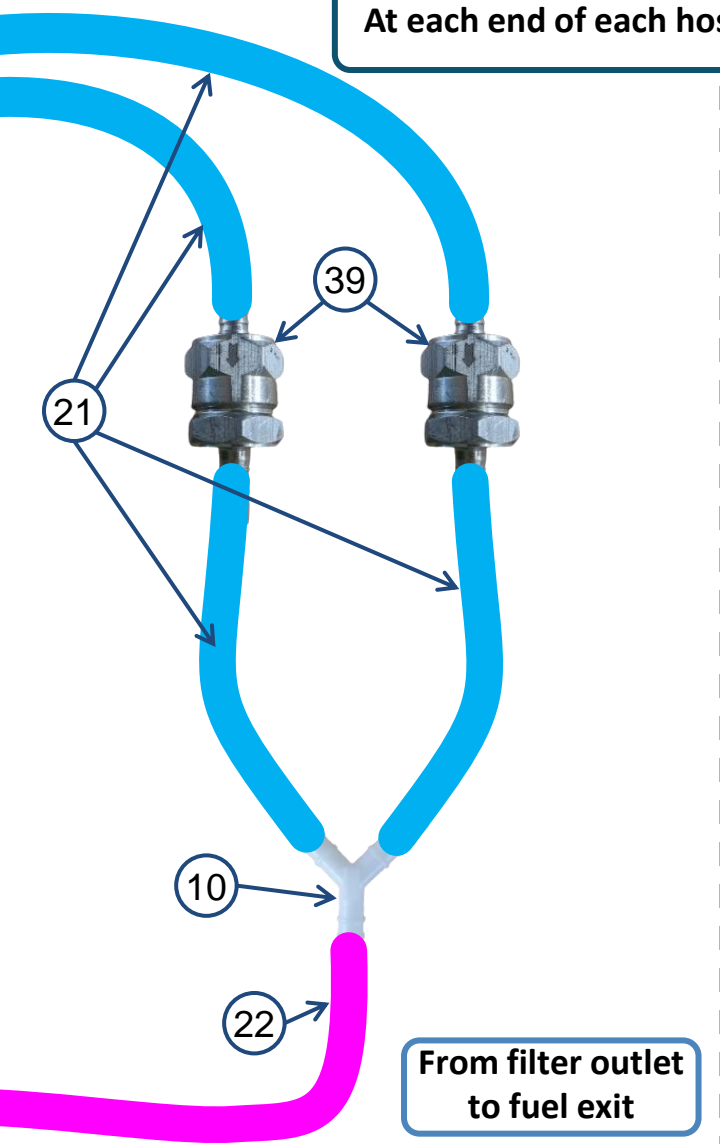

Fuel Exit

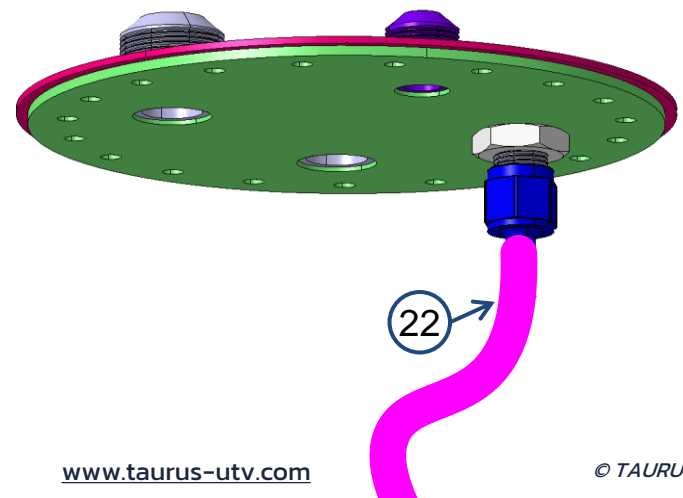

**4.1.12 FUEL STORAGE – Fuel Tank – Electrical Connections**

**Aluminum fuel tank**

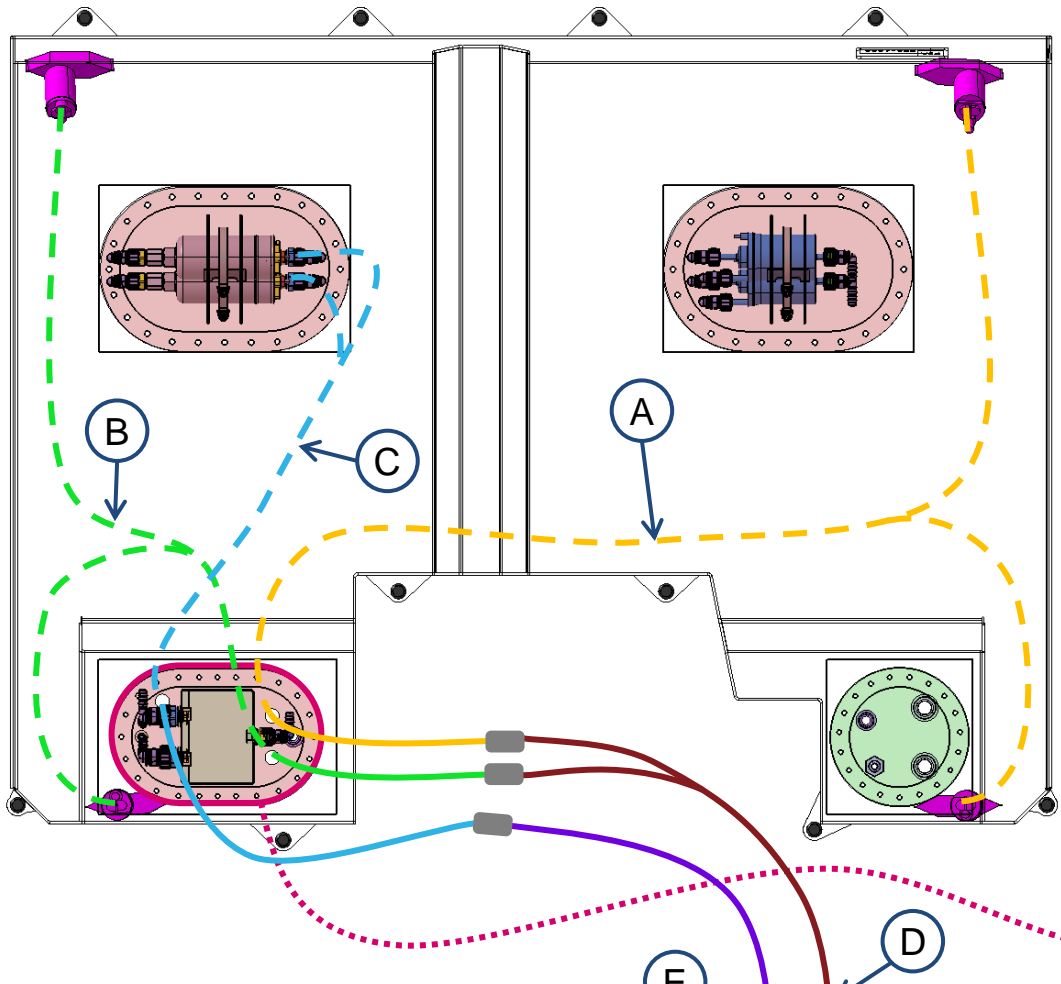

----- Inside fuel tank  
 \_\_\_\_\_ Outside fuel tank

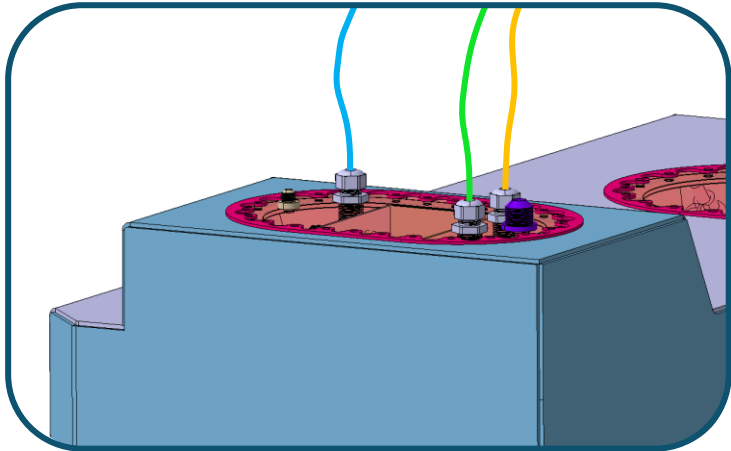

**Cable glands details**

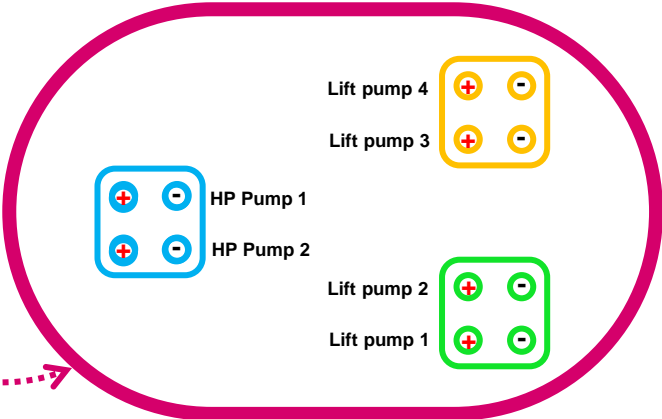

No.	Ref.	Name	Qty.
A	4018768	SASS-WIRING LIFT FUEL PUMPS 1 & 2	1
B	4018769	SASS-WIRING LIFT FUEL PUMPS 3 & 4	1
C	4013037	SASS-WIRING HP FUEL PUMPS	1
D	4013035	DRP-WIRING HARNESS FEEDING PUMPS	1
E	4014890	DRP-HARNESS EXTENSION FROM ECU HARNESS TO HP FUEL PUMP HARNESS	1

**4.1.12 FUEL STORAGE – Fuel Tank – Electrical Connections**

**Aluminium fuel tank**

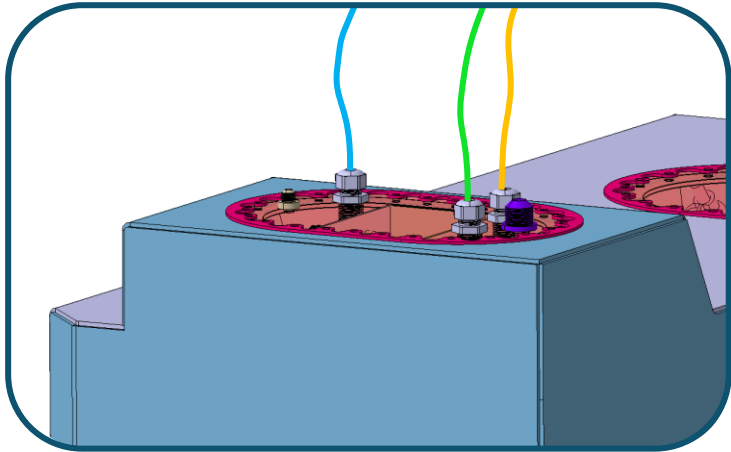
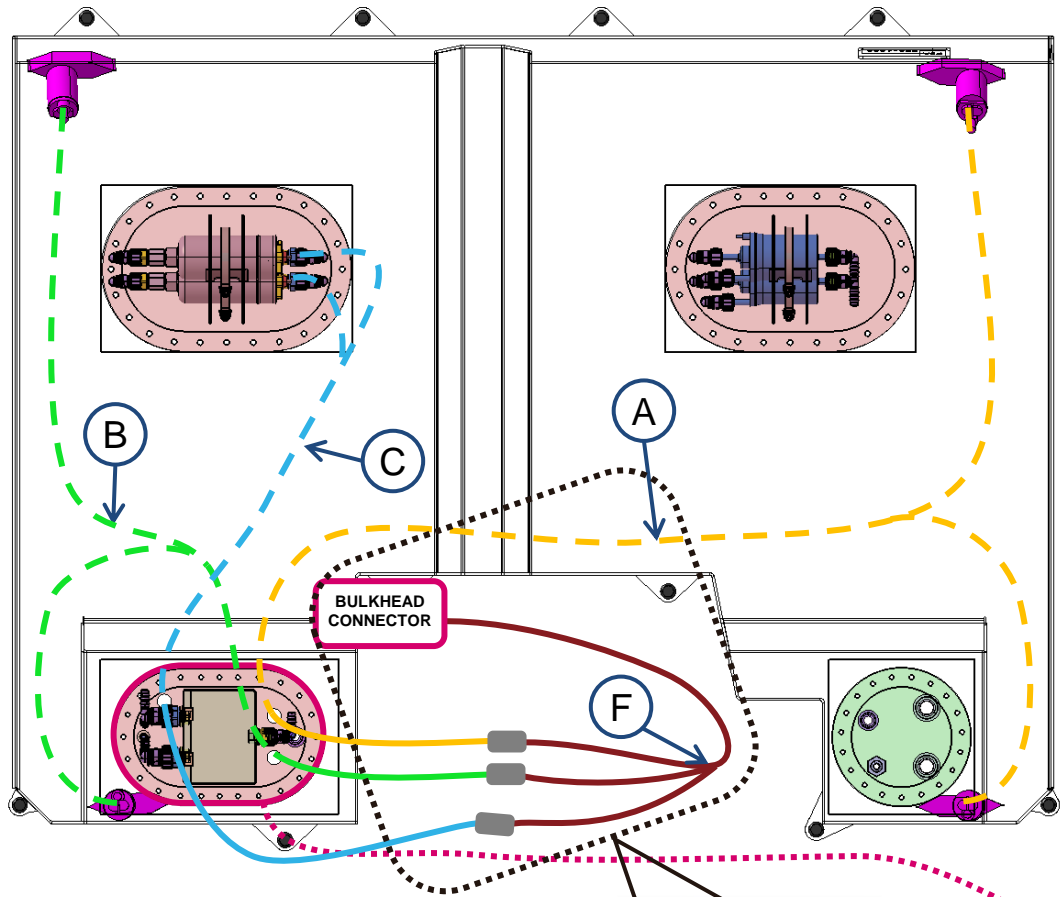

**Cable glands details**

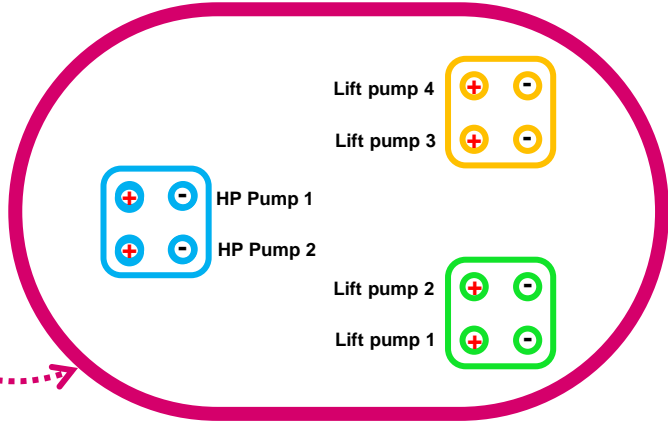

----- Inside fuel tank  
 ——— Outside fuel tank

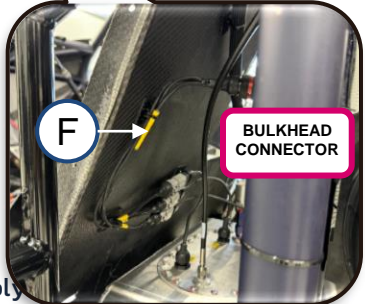

No.	Ref.	Name	Qty.
A	4018769	SASS-WIRING LIFT FUEL PUMPS 3 & 4 - 2023+	1
B	4018768	SASS-WIRING LIFT FUEL PUMPS 1 & 2 - 2023+	1
C	4013037	SASS-WIRING HP FUEL PUMPS	1
F	4020440	SASS-WIRING FUEL PUMP REALR ALUMINIUM FC	1

## 4.2 FUEL STORAGE – Fuel Tank Pressure Relief

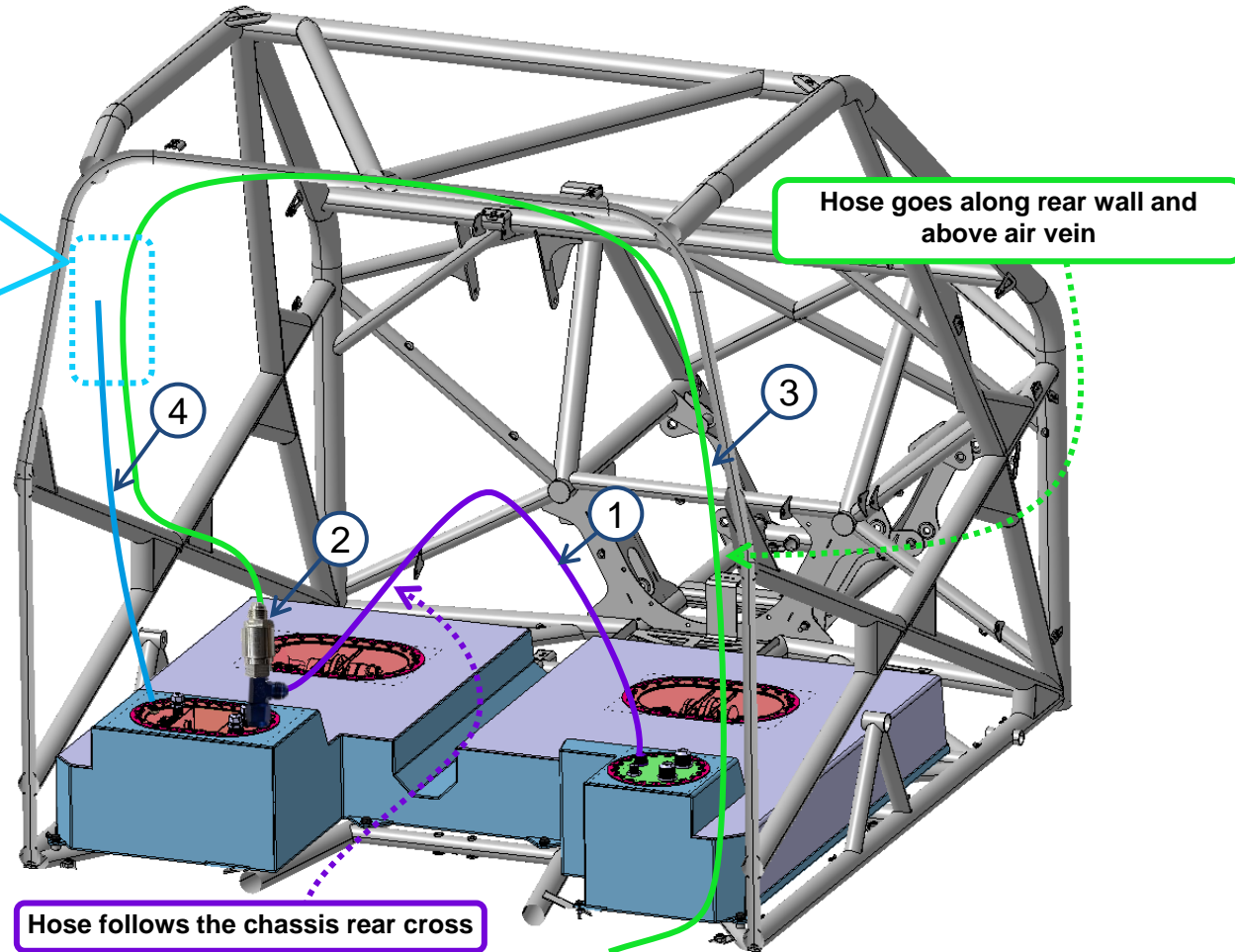

No.	Ref.	Name	Qty.
1	4016490	COP-HOSE VENTILATION JUNCTION LG: 1240MM	1
2	4014145	COP-VALVE DE DÉGAZAGE ET ANTI-RETOURNEMENT	1
3	4016491	COP-HOSE VENTING LG: 3330MM	1
4	4016494	COP-HOSE TO PRESSURE RELIEF VALVE 200MB LG:780MM	1



## 4.3.1 FUEL STORAGE – Fuel Tank – Overview

### Composite fuel tank

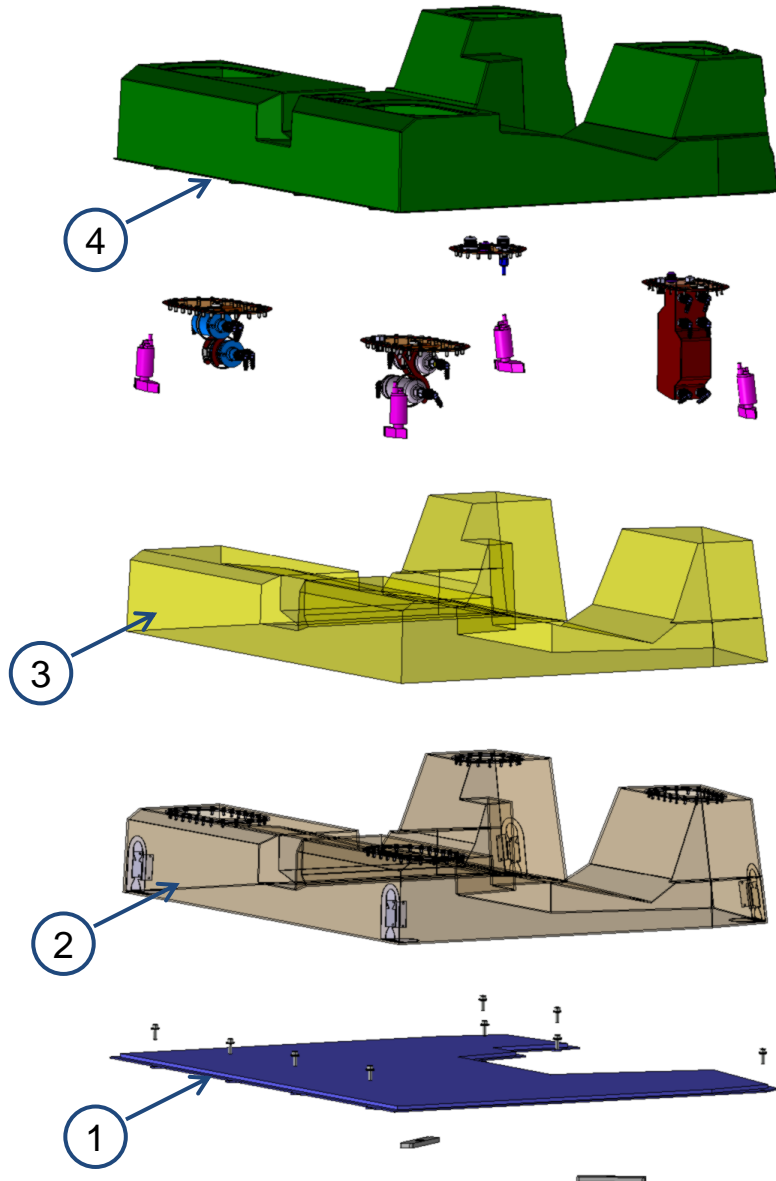

No.	Ref.	Name	Qty.
1	4019998	DRP-COMPOSITE FUEL TANK FLANGE	1
2	4020001	DRP-COMPOSITE FUEL TANK BLADDER	1
3	4020002	COP-COMPOSITE FUEL TANK FOAM KIT	1
4	4019999	DRP-COMPOSITE FUEL TANK COVER	1
5	4014969	DRP-WEDGE-UNDER FUEL TANK	2
6	4009167	SUP-PLAIN WASHER	9
7	4000965	SUP-HEXAGONAL SOCKET CAP SCREW	9
8	4019971	SASS-COVER FUEL CELL - FRONT LEFT – WELDED	1
9	4014108	COP-STUFFING-BOX - FUEL TANK	1
10	4018495	DRP-FLANGE FRONT COVER	2
11	4008398	SUP-BUTTON HEAD SCREW	48
12	4019975	SASS-COVER FUEL CELL - FRONT RIGHT – WELDED	1
13	4017045	SASS-COVER FUEL CELL - REAR RIGHT – WELDED	1
14	4014864	COP-ADAPTER DASH BULKHEAD PASS	1
15	4014925	COP-NUT JAM HEX – ALU	1
16	4019985	DRP-FLANGE REAR RIGHT COVER	1
17	4008384	SUP-BUTTON HEAD SCREW	39
18	4017070	SASS-COVER FUEL BUFFER BOX – WELDED	1
19	4014108	COP-STUFFING-BOX –FUEL TANK	2
20	4018496	DRP-FLANGE BUFFER BOX	1
21	4012410	SUP-FILTER	2
22	4016642	COP-PUMP LOW PRESSURE FUEL + FILTER - LIFT PUMP	4
23	4014485	COP-PUMP FUEL	2
24	4014876	COP-COPPER GASKET	2
25	4021811	MCE-DRP-ADAPTER QUICK CONNECTOR MALE	2
26	4014875	COP-COPPER GASKET	1
27	4018625	MCE-DRP-ADAPTER QUICK CONNECTOR MALE	2
28	2003775	DFM-COP-SUPPLY SC HOSE CLAMP	4
29	4017609	COP-CONNECTOR RACCORD UNION	1
30	4018094	SUP-CONNECTOR QUICK FIT COUDE 90°	17
31	4020051	COP-HOSE LIFT PUMP 1	1
32	4020052	COP-HOSE LIFT PUMP 2	1
33	4020053	COP-HOSE LIFT PUMP 3	1
34	4020054	COP-HOSE LIFT PUMP 4	1
35	4020059	COP-HOSE BUFFER BOX - HP PUMP	2
36	4020060	COP-HOSE HP PUMP – FILTER	2
37	4020061	COP-HOSE INTERMEDIATE	6
38	4020062	COP-HOSE CHECK VALVE - TANK OUT	1
39	4020063	COP-HOSE BYPASS - BUFFER BOX	1
40	4018122	COP-CONNECTOR Y	2
41	4018662	COP-CHECK VALVE	2
42	4018760	SUP-HOSE CLAMP	32
43	4014322	MCE-SUP-LOCKNUT WITH FLANGE	1

### 4.3.2 FUEL STORAGE – Fuel Tank – Fixing To Chassis

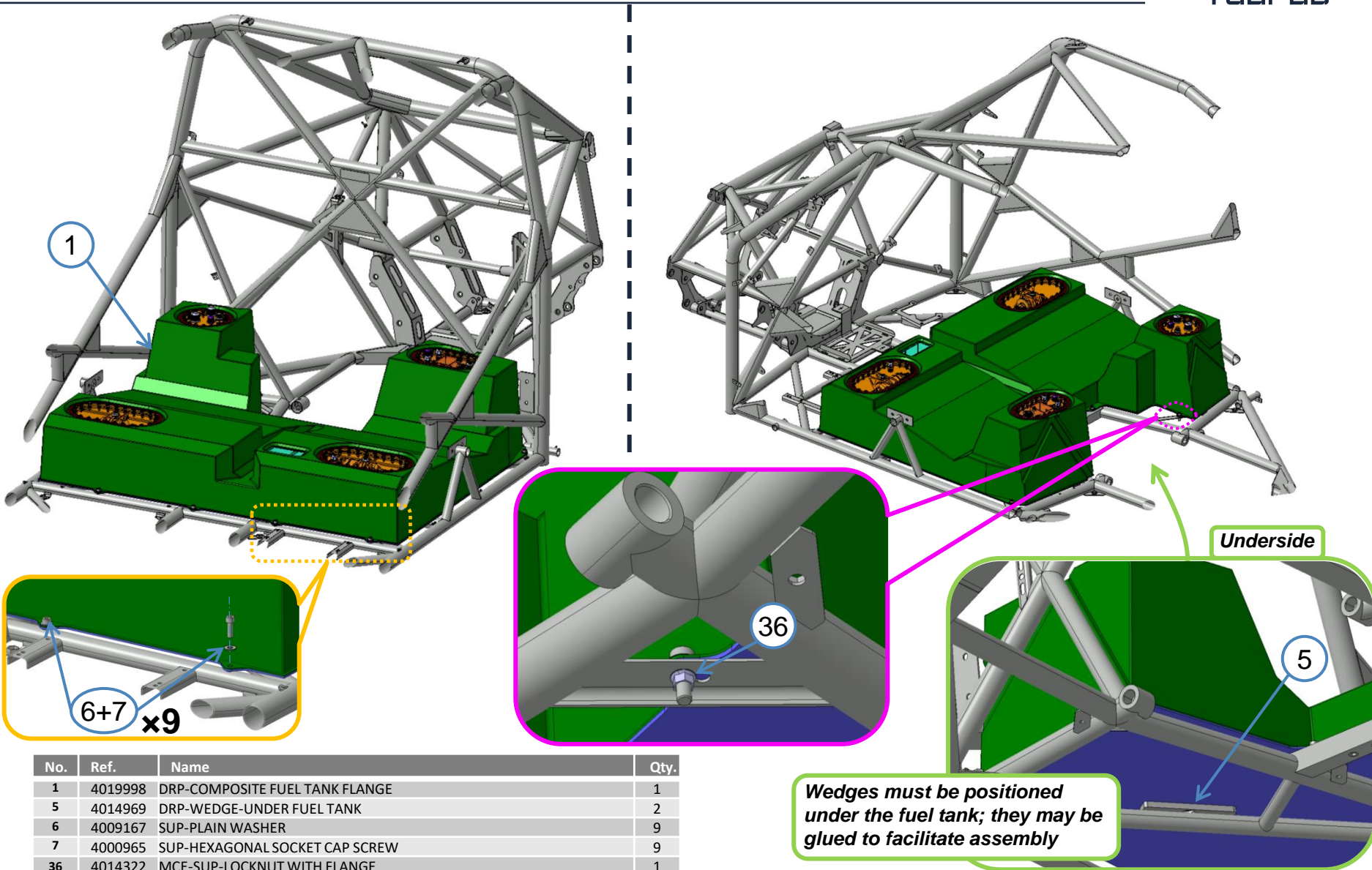

No.	Ref.	Name	Qty.
1	4019998	DRP-COMPOSITE FUEL TANK FLANGE	1
5	4014969	DRP-WEDGE-UNDER FUEL TANK	2
6	4009167	SUP-PLAIN WASHER	9
7	4000965	SUP-HEXAGONAL SOCKET CAP SCREW	9
36	4014322	MCE-SUP-LOCKNUT WITH FLANGE	1

## 4.3.3 FUEL STORAGE – Fuel Tank – Fuel Buffer Box Equipped

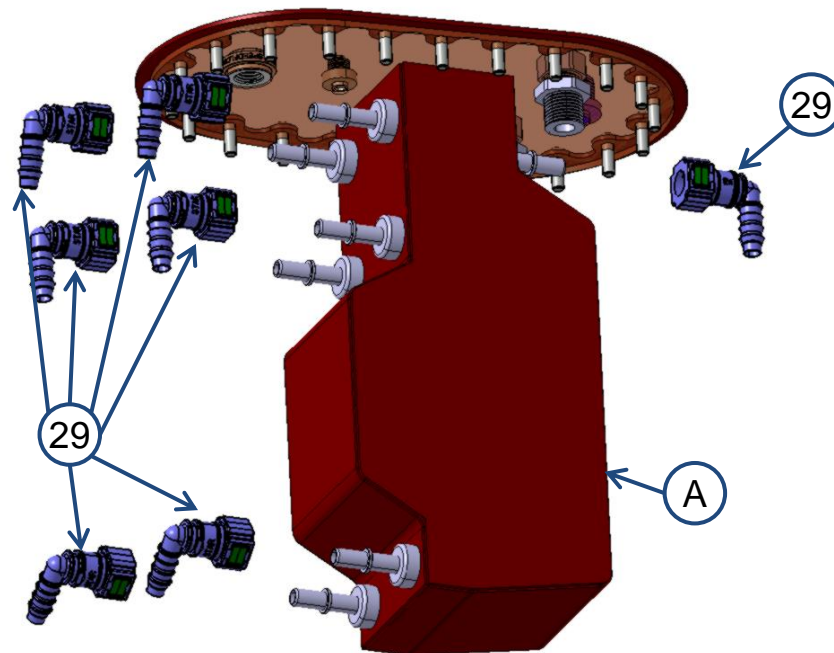
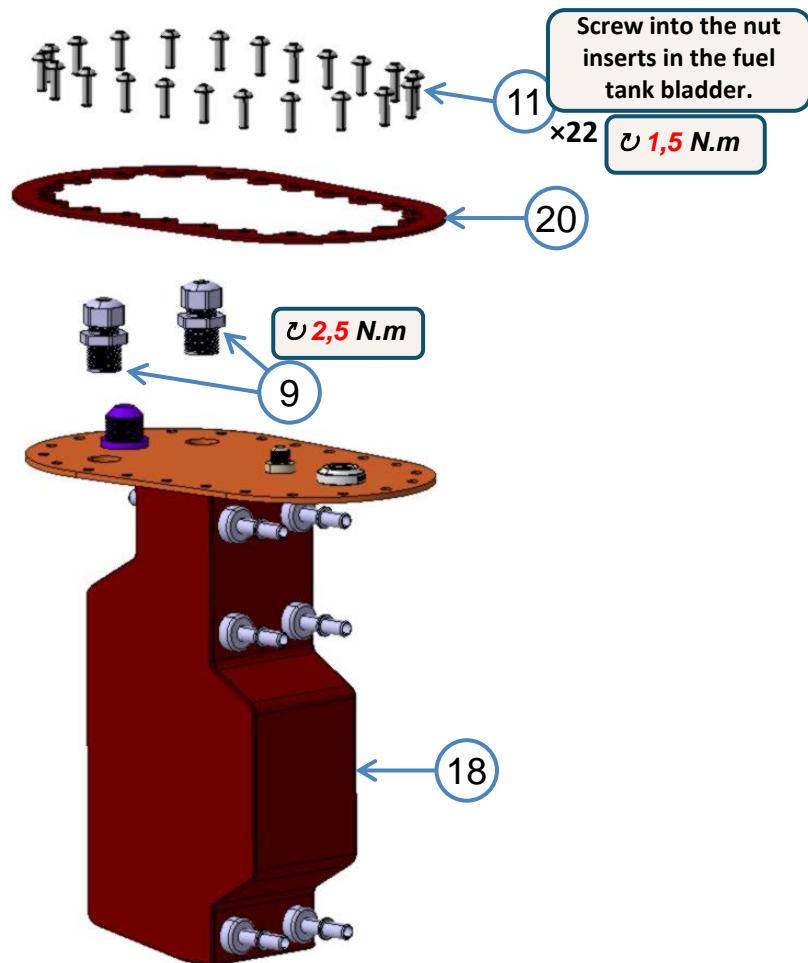

No.	Ref.	Name	Qty.
A	4016942	SASS-COVER FUEL BUFFER BOX – EQUIPPED	-
18	4017070	SASS-COVER FUEL BUFFER BOX – WELDED	1
9	4014108	COP-STUFFING-BOX – FUEL TANK	2
20	4018496	DRP-FLANGE BUFFER BOX	1
11	4008384	SUP-BUTTON HEAD SCREW ISO 7380 M5X16-16 P80 CL70 A2	22

No.	Ref.	Name	Qty.
A	4016942	SASS-COVER FUEL BUFFER BOX – EQUIPPED	1
29	4018094	MCE-SUP-CONNECTOR QUICK FIT COUDE 90°, Ø 8 MM	7

### 4.3.4 FUEL STORAGE – Fuel Tank composite – Foam

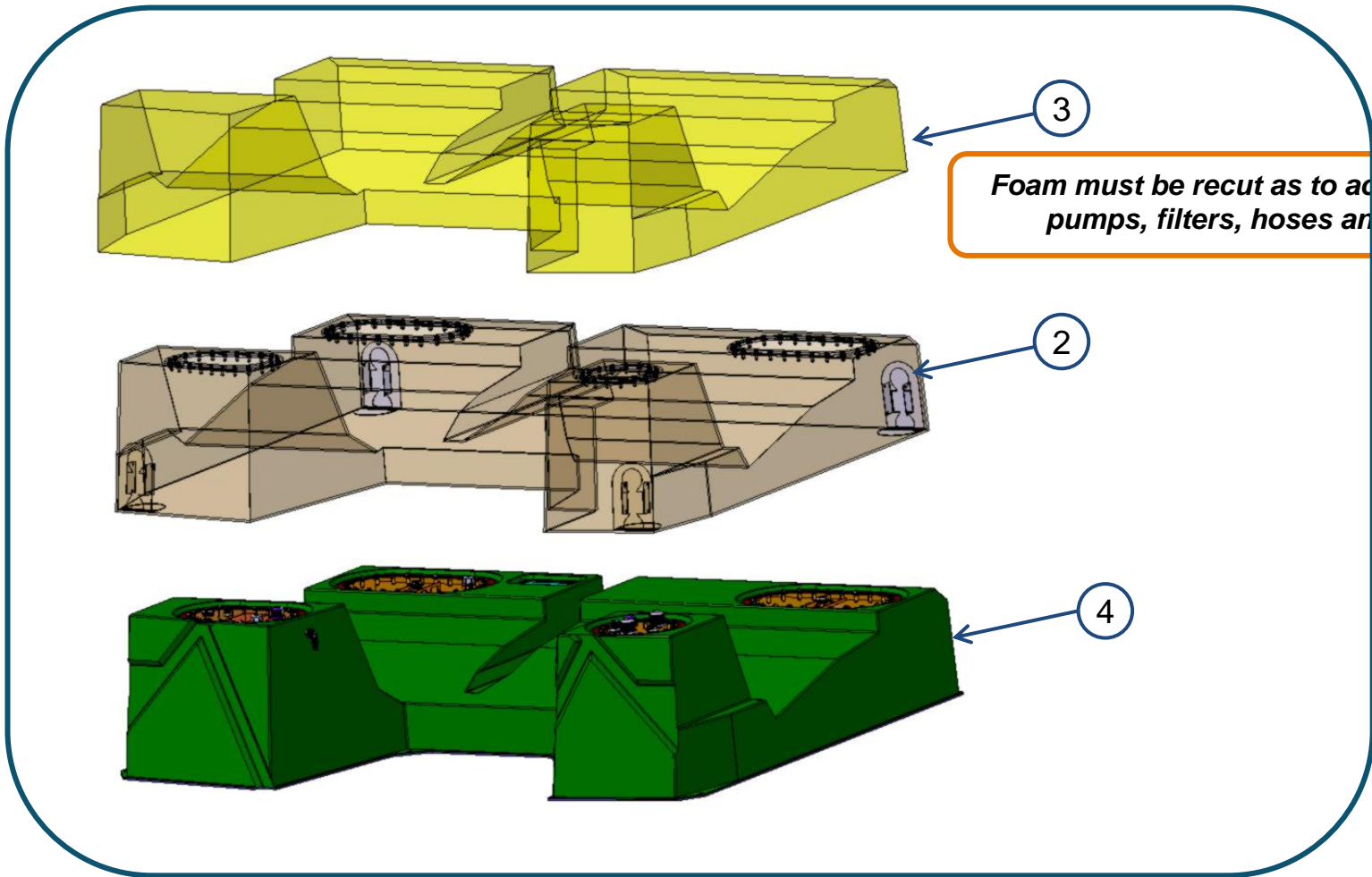

No.	Ref.	Name	Qty.
2	4020001	DRP-COMPOSITE FUEL TANK BLADDER	1
3	4020002	COP-COMPOSITE FUEL TANK FOAM KIT	1
4	4019999	DRP-COMPOSITE FUEL TANK COVER - GEN 1	1

## 4.3.5 FUEL STORAGE – Fuel Tank composite – HP Pumps

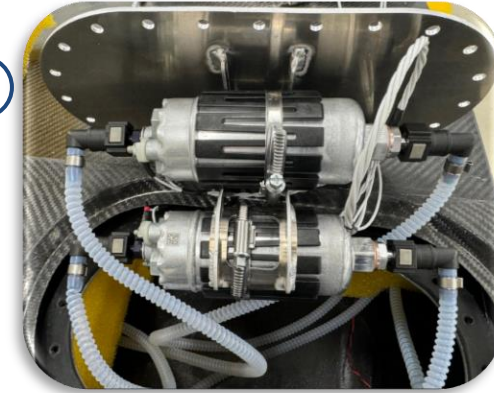
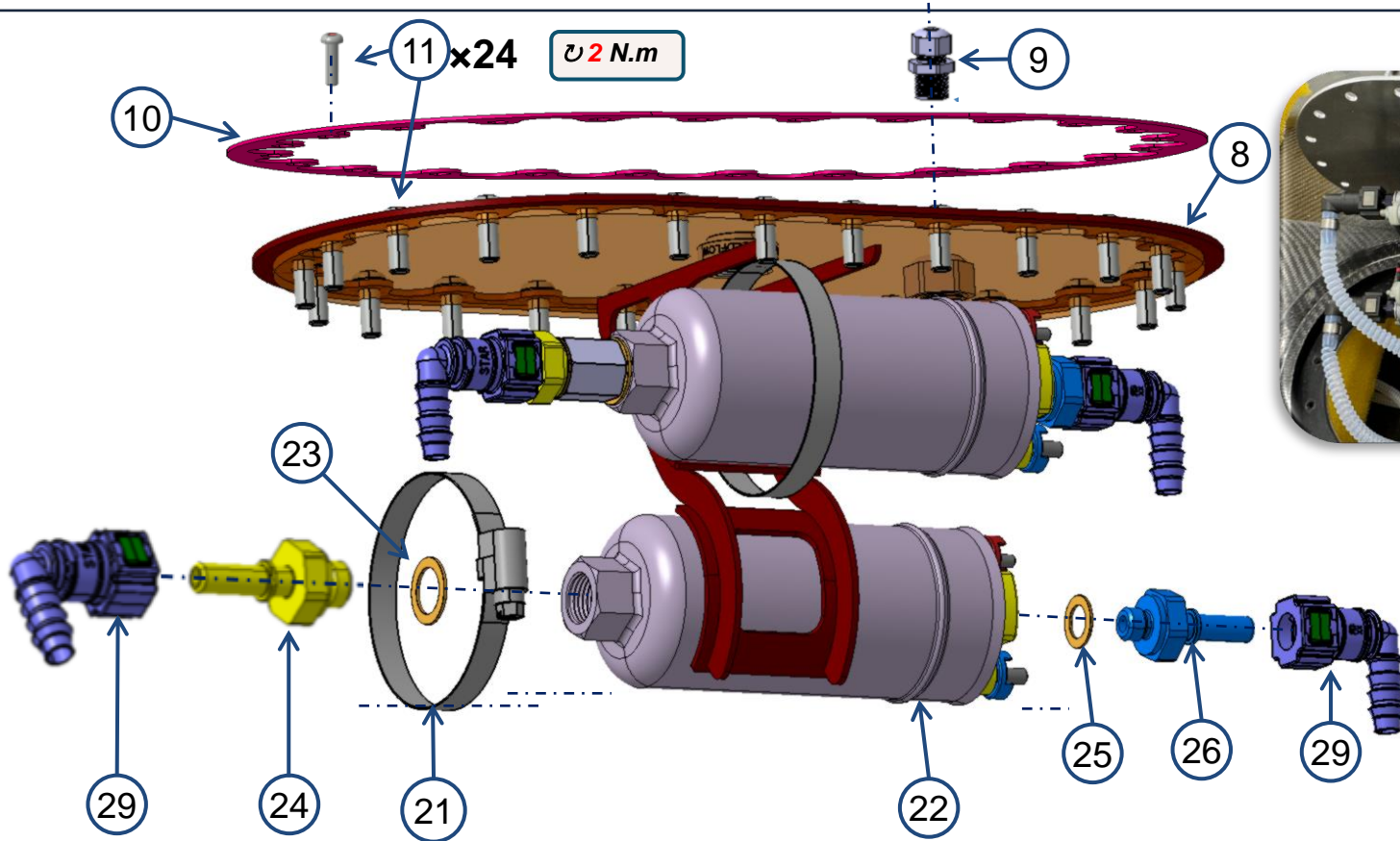

No.	Ref.	Name	Qty.
8	4017043	SASS-COVER FUEL CELL - FRONT LEFT - WELDED	1
9	4014108	COP-STUFFING-BOX - FUEL TANK	1
10	4018495	DRP-FLANGE FRONT COVER	1
11	4008398	SUP-BUTTON HEAD SCREW	24
22	4014485	COP-PUMP FUEL	2
23	4014876	COP-COPPER GASKET	2
24	4021811	MCE-DRP-ADAPTER QUICK CONNECTOR MALE	2
25	4014875	COP-COPPER GASKET	1
26	4018625	MCE-DRP-ADAPTER QUICK CONNECTOR MALE	2
27	2003775	DFM-COP-SUPPLY SC HOSE CLAMP	4
29	4018094	SUP-CONNECTOR QUICK FIT COUDE 90°	4

## 4.3.6 FUEL STORAGE – Fuel Tank composite – Filters And Fuel Exit

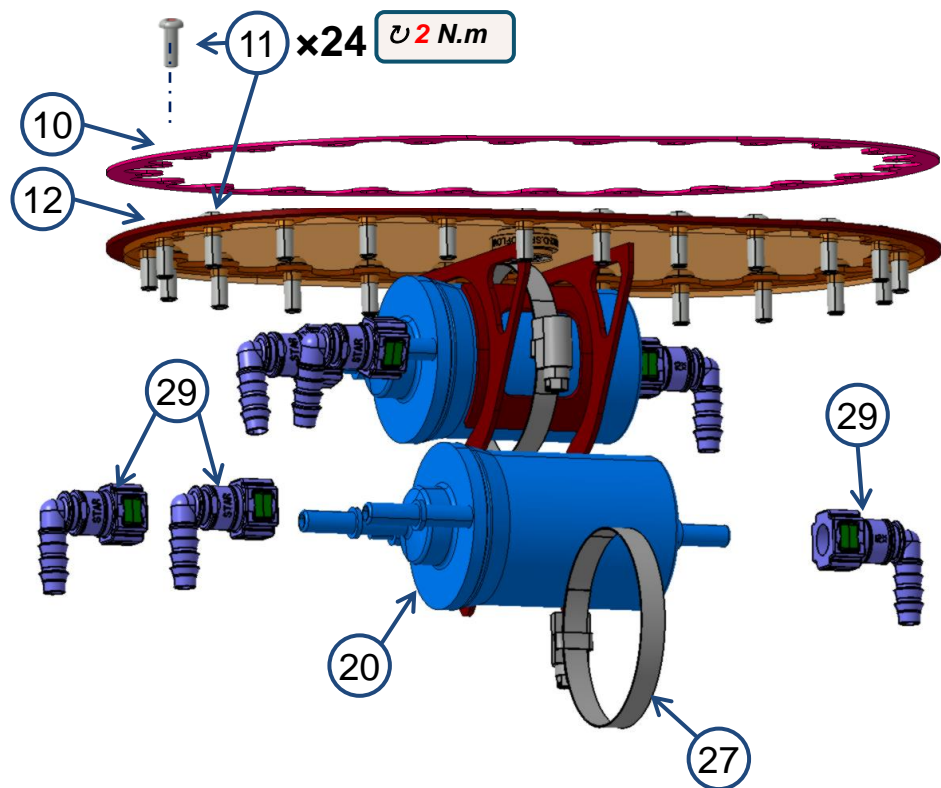

No.	Ref.	Name	Qty.
12	4019975	SASS-COVER FUEL CELL - FRONT RIGHT - WELDED	1
10	4018495	DRP-FLANGE FRONT COVER	1
11	4008398	SUP-BUTTON HEAD SCREW	24
20	4012410	SUP-FILTER	2
27	2003775	DFM-COP-SUPPLY SC HOSE CLAMP	4
29	4018094	SUP-CONNECTOR QUICK FIT COUDE 90°	17

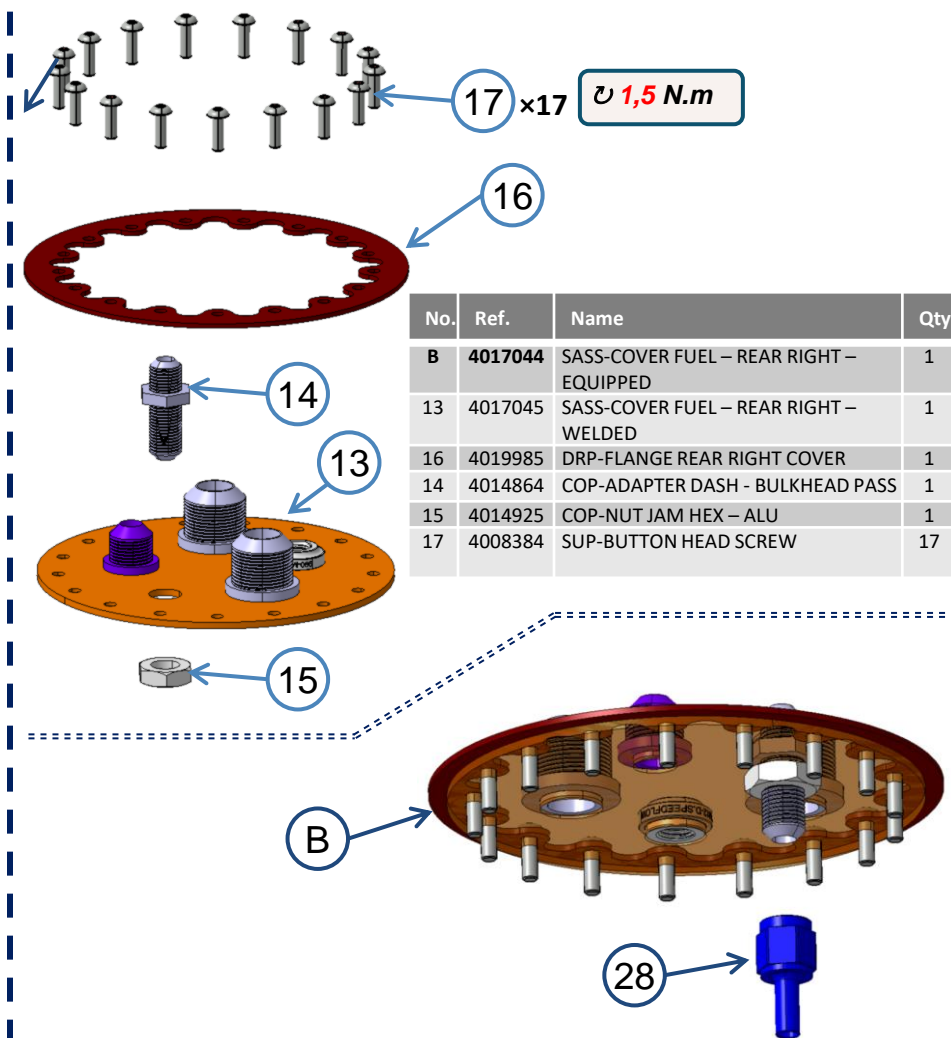

No.	Ref.	Name	Qty.
<b>B</b>	<b>4017044</b>	SASS-COVER FUEL – REAR RIGHT – EQUIPPED	1
13	4017045	SASS-COVER FUEL – REAR RIGHT – WELDED	1
16	4019985	DRP-FLANGE REAR RIGHT COVER	1
14	4014864	COP-ADAPTER DASH - BULKHEAD PASS	1
15	4014925	COP-NUT JAM HEX – ALU	1
17	4008384	SUP-BUTTON HEAD SCREW	17

No.	Ref.	Name	Qty.
<b>B</b>	<b>4017044</b>	SASS-COVER FUEL – REAR RIGHT – EQUIPPED	1
28	4017609	COP-CONNECTOR RACCORD UNION JIC	1

### 4.3.7 FUEL STORAGE – Fuel Tank composite – Lift Pumps

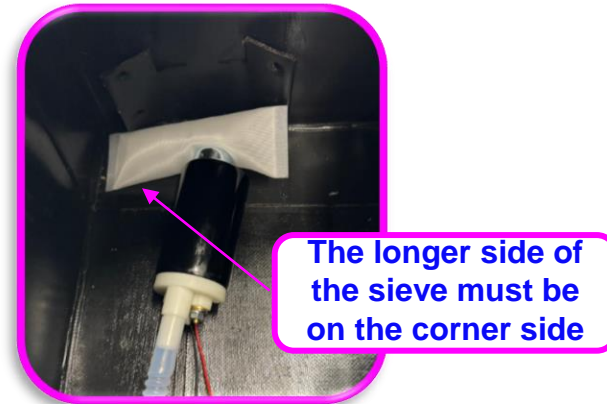
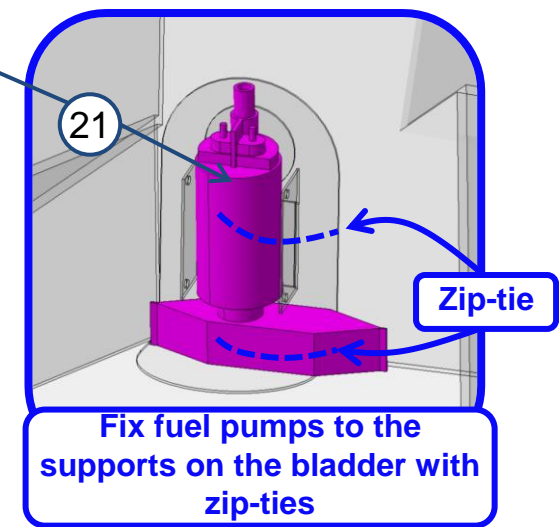
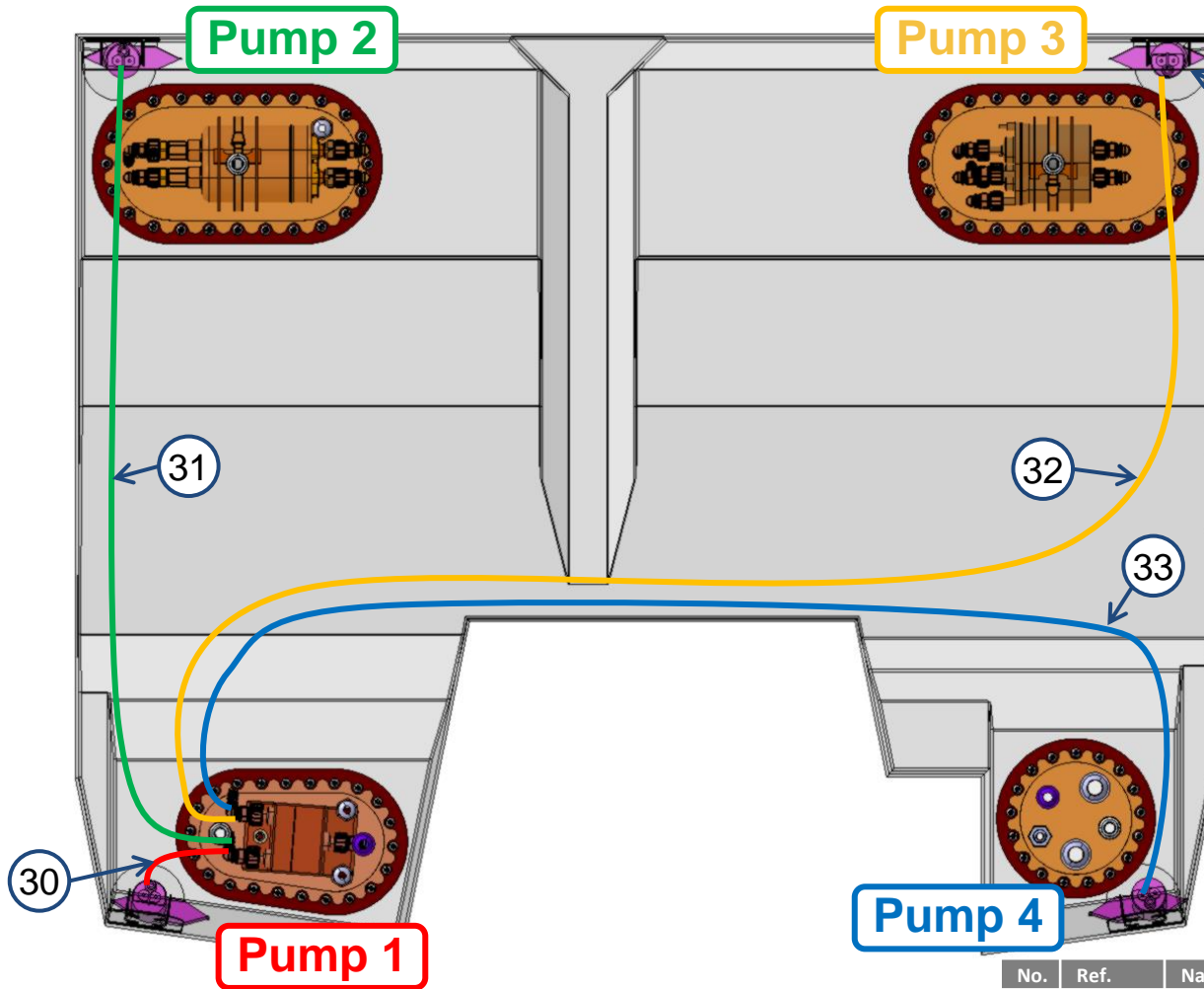

**At each end of each hose use a hose clamp #41**

No.	Ref.	Name	Qty.
21	4016642	COP-PUMP LOW PRESSURE FUEL + FILTER - LIFT PUMP	4
30	4020051	MCE-COP-HOSE LIFT PUMP 1	1
31	4020052	MCE-COP-HOSE LIFT PUMP 2	1
32	4020053	MCE-COP-HOSE LIFT PUMP 3	1
33	4020054	MCE-COP-HOSE LIFT PUMP 4	1
41	4018760	MCE-SUP-HOSE CLAMP	8

### 4.3.8 FUEL STORAGE – Fuel Tank composite – Hp Pumps, Filters And Exit

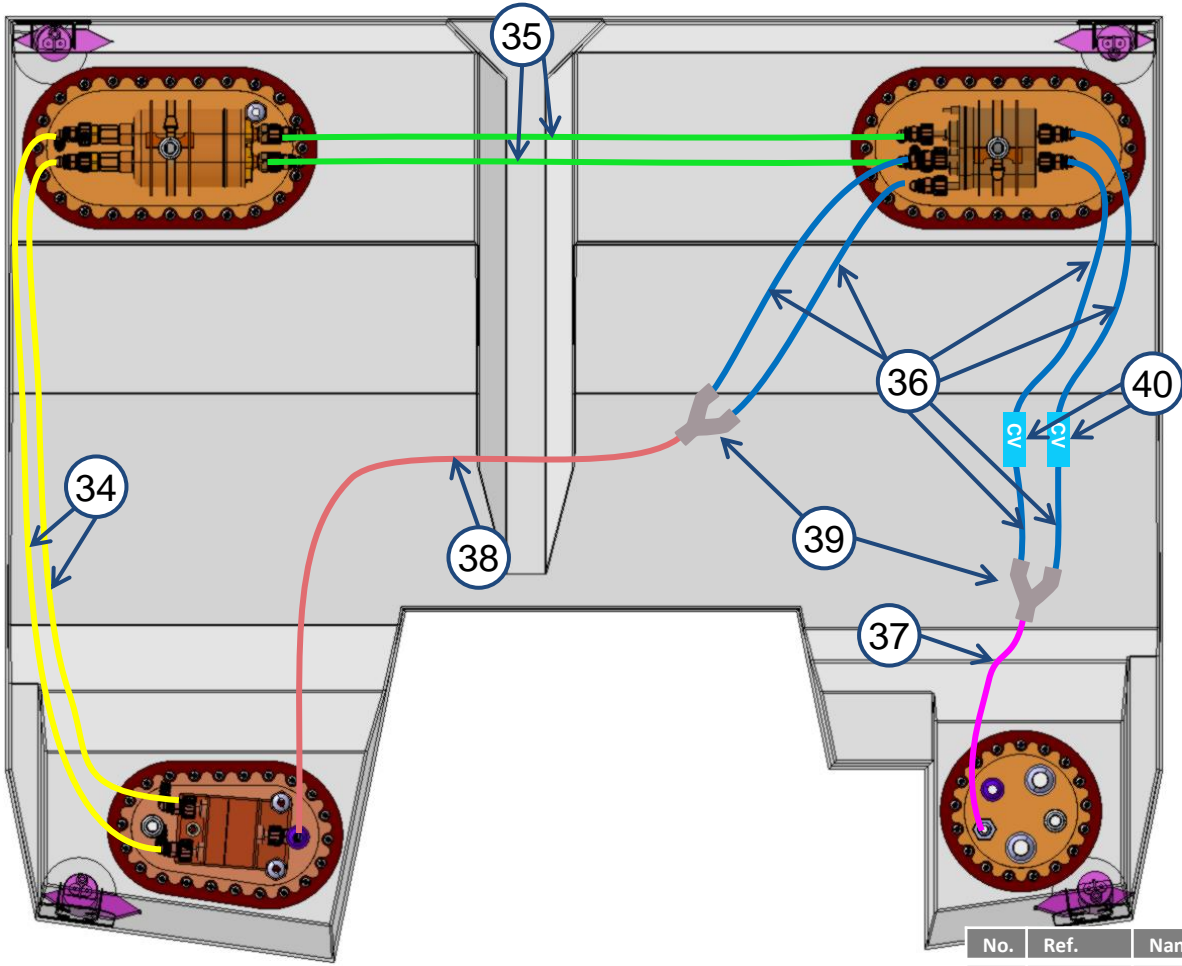

**At each end of each hose use a hose clamp #41**

No.	Ref.	Name	Qty.
34	4020059	MCE-COP-HOSE BUFFER BOX – HP PUMP	2
35	4020060	MCE-COP-HOSE HP PUMP - FILTER	2
36	4020061	MCE-COP-HOSE INTERMEDIATE	6
37	4020062	MCE-COP-HOSE CHECK VALVE – TANK OUT	1
38	4020063	MCE-COP-HOSE BY PASS – BUFFER BOX	1
39	4018122	MCE-COP-CONNECTOR Y	2
40	4018662	MCE-COP-TO BE DEFINED CHECK VALVE	2
41	4018760	MCE-SUP-HOSE CLAMP	24





4.3.9 FUEL STORAGE – Fuel Tank composite – Buffer Box Connection Details

Buffer box, from lift pumps and towards HP pumps

At each end of each hose use a hose clamp #41

Buffer box, from filter bypass

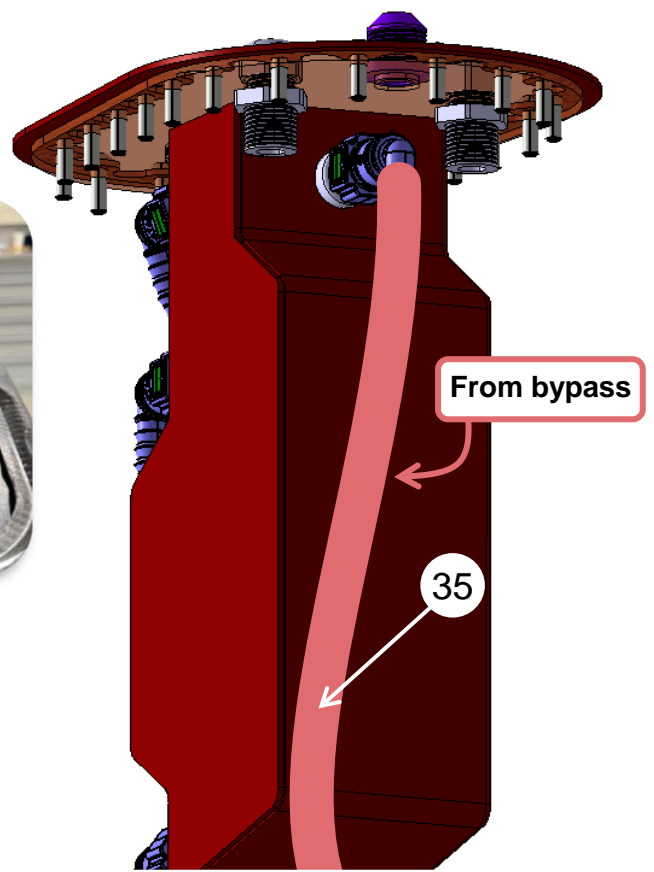
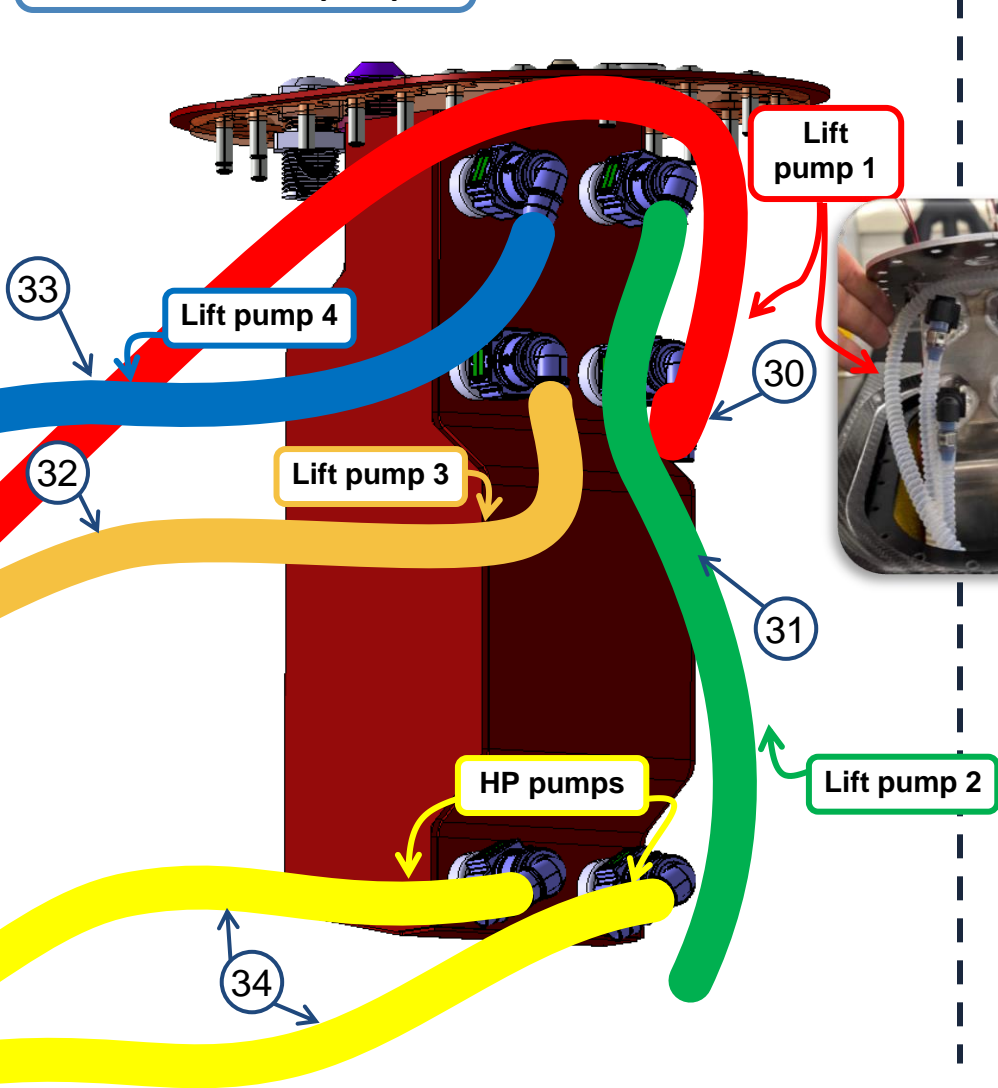

No.	Ref.	Name	Qty.
30	4020051	COP-HOSE LIFT PUMP 1	1
31	4020052	COP-HOSE LIFT PUMP 2	1
32	4020053	COP-HOSE LIFT PUMP 3	1
33	4020054	COP-HOSE LIFT PUMP 4	1
34	4020059	COP-HOSE BUFFER BOX - HP PUMP	2
35	4020063	COP-HOSE BYPASS - BUFFER BOX	1

# Composite fuel tank



## 4.3.10 FUEL STORAGE – Fuel Tank composite – Pump And Filter Details

HP pumps

At each end of each hose use a hose clamp #41

Fuel filter

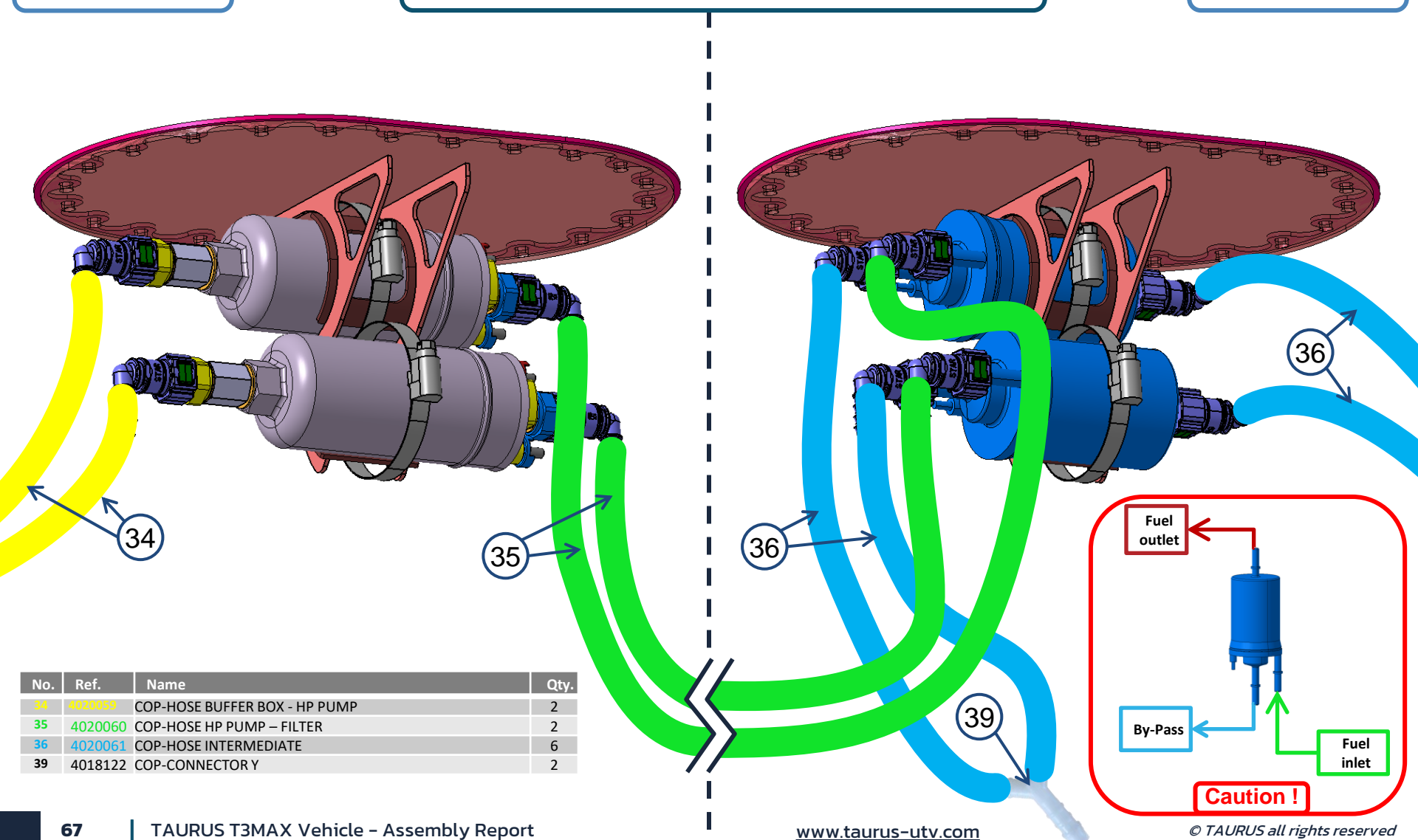

No.	Ref.	Name	Qty.
34	4020059	COP-HOSE BUFFER BOX - HP PUMP	2
35	4020060	COP-HOSE HP PUMP – FILTER	2
36	4020061	COP-HOSE INTERMEDIATE	6
39	4018122	COP-CONNECTORY	2

### 4.3.11 FUEL STORAGE – Fuel Tank composite – Exit Details

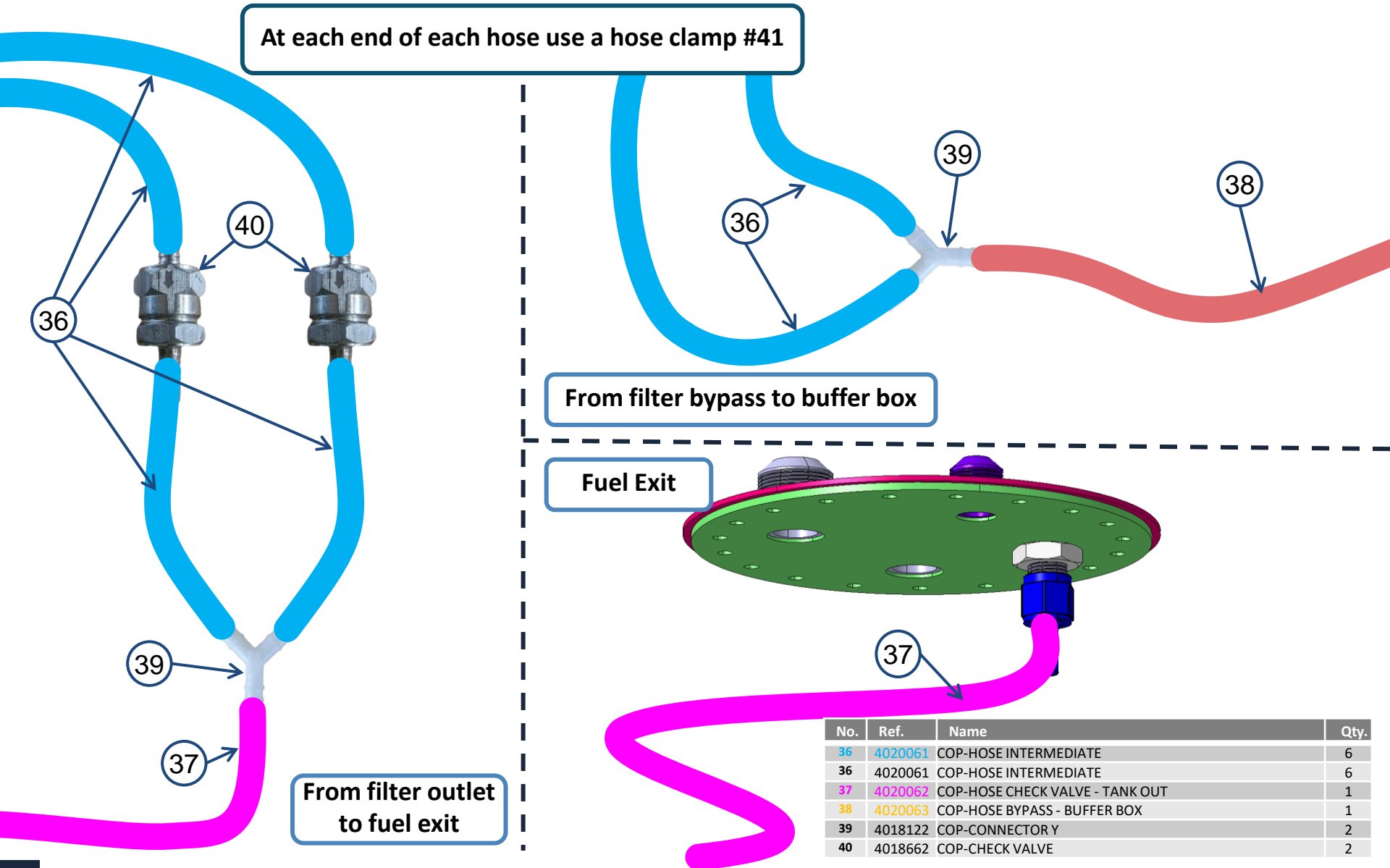

# Composite fuel tank



## 4.3.12 FUEL STORAGE – Fuel Tank composite– Electrical Connections

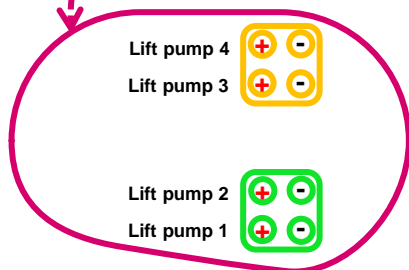
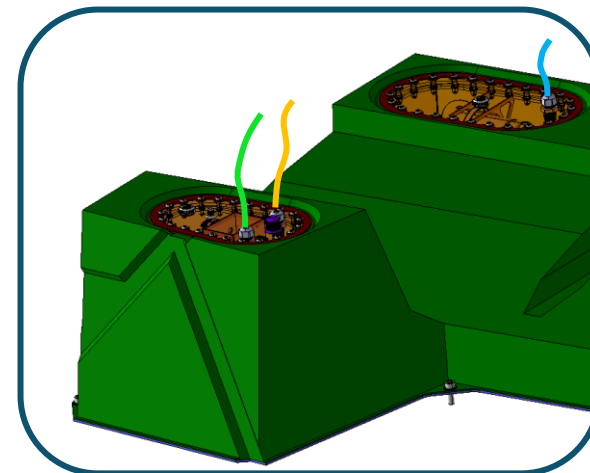
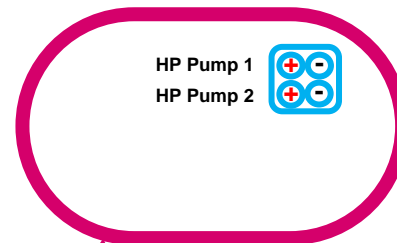
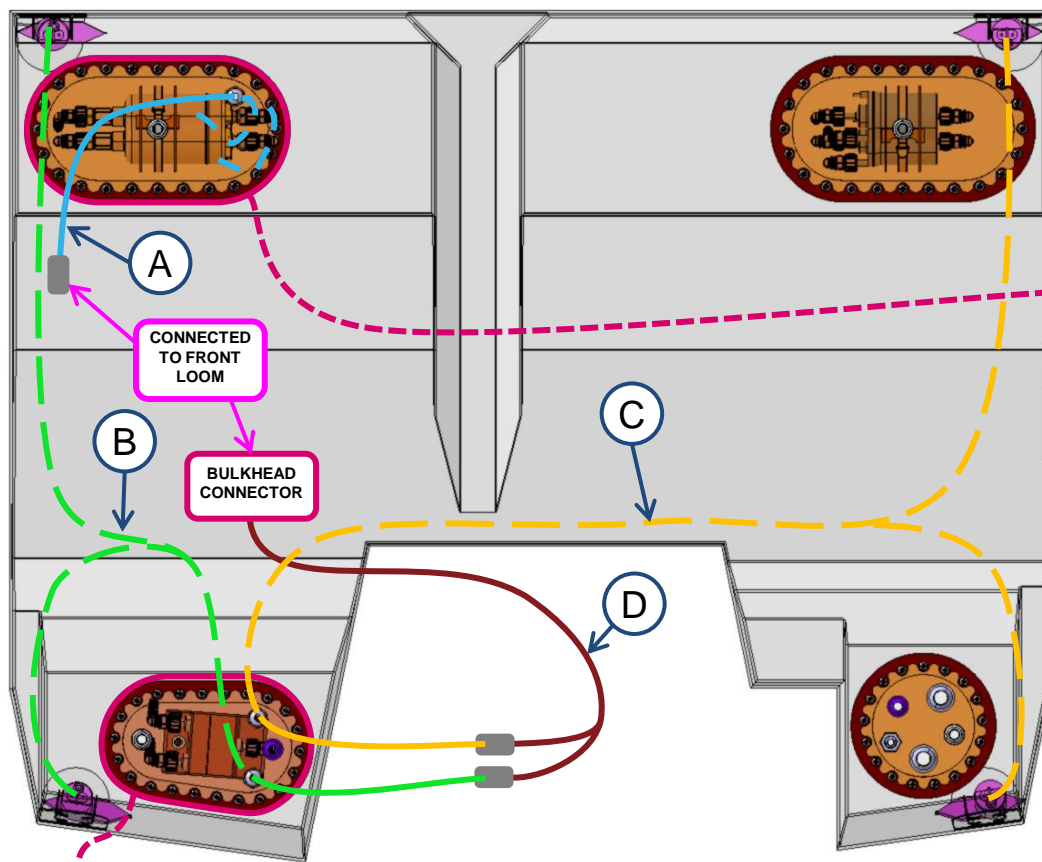

----- Inside fuel tank  
 \_\_\_\_\_ Outside fuel tank

No.	Ref.	Name	Qty.
A	4020405	SASS-HARNES HP FUEL PUMPS	1
B	4018768	SASS-WIRING LIFT FUEL PUMPS 1 & 2	1
C	4018769	SASS-WIRING LIFT FUEL PUMPS 3 & 4	1
D	4020441	SASS-WIRING FUEL PUMP REAR COMPOSITE FC	1

## 4.3.12 FUEL STORAGE – Fuel Tank composite– Electrical Connections

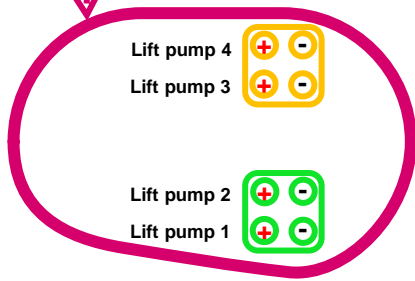
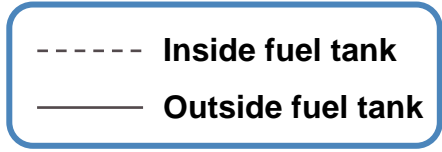
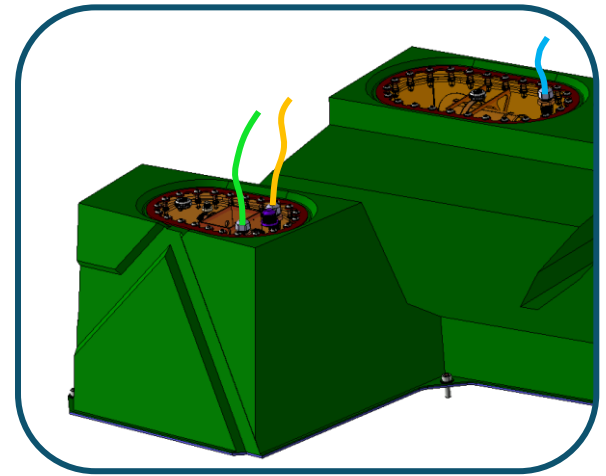
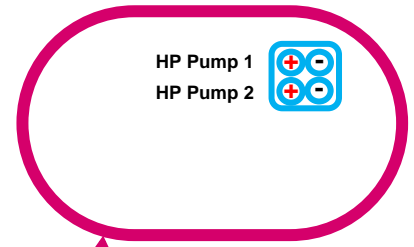
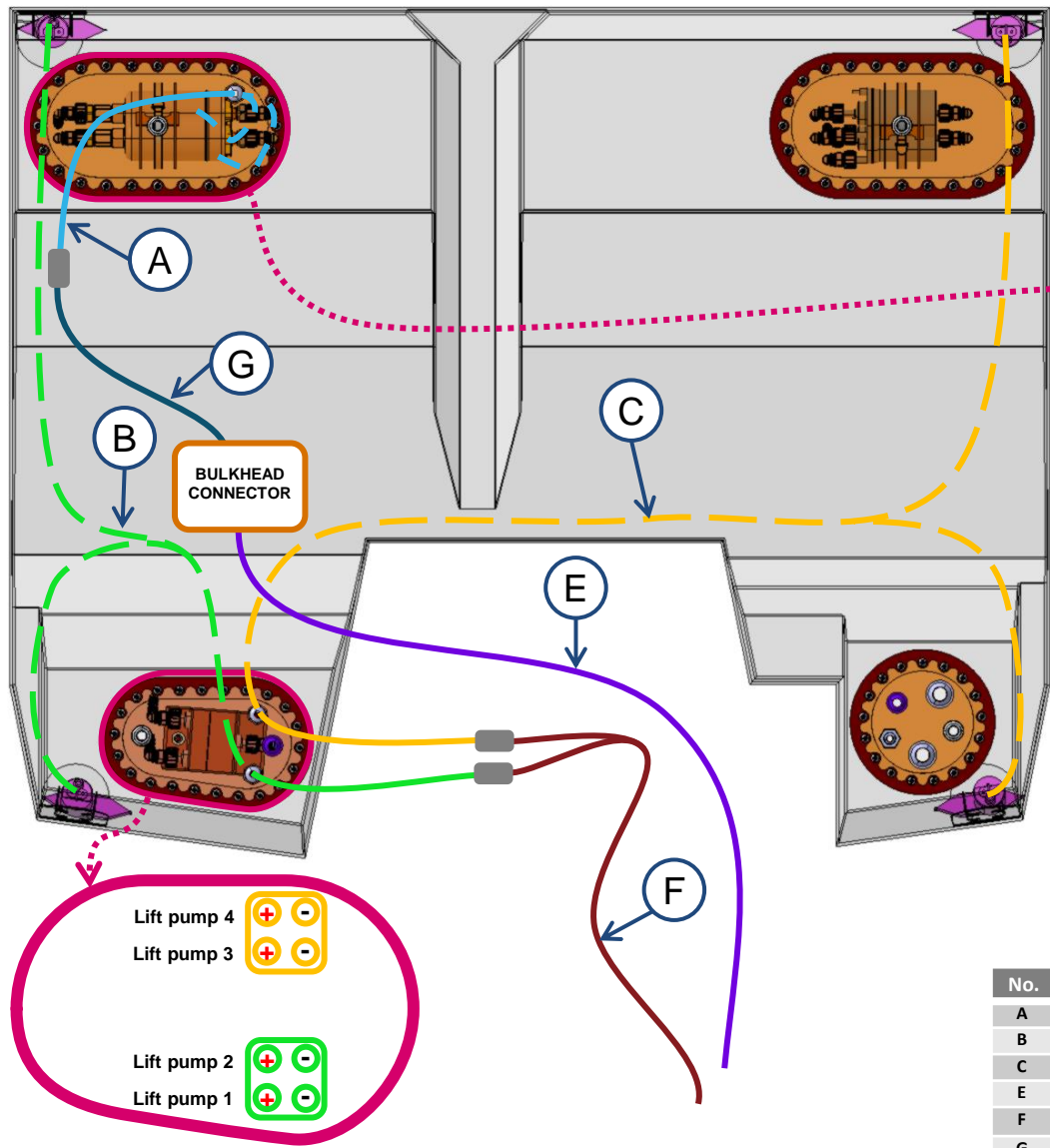

No.	Ref.	Name	Qty.
A	4020405	SASS-HARNESS HP FUEL PUMPS	1
B	4018768	SASS-WIRING LIFT FUEL PUMPS 1 & 2	1
C	4018769	SASS-WIRING LIFT FUEL PUMPS 3 & 4	1
E	4013035	DRP-HARNESS FEEDING PUMPS	1
F	4014890	DRP-HARNESS EXTENSION FROM ECU HARNESS TO FUEL PUMP HARNESS	1
G	4020070	DRP- HARNESS EXTENSION FROM FUEL PUMP to BULKHEAD	1

## 4.4 FUEL STORAGE – Fuel Tank Pressure Relief for composite fuel tank

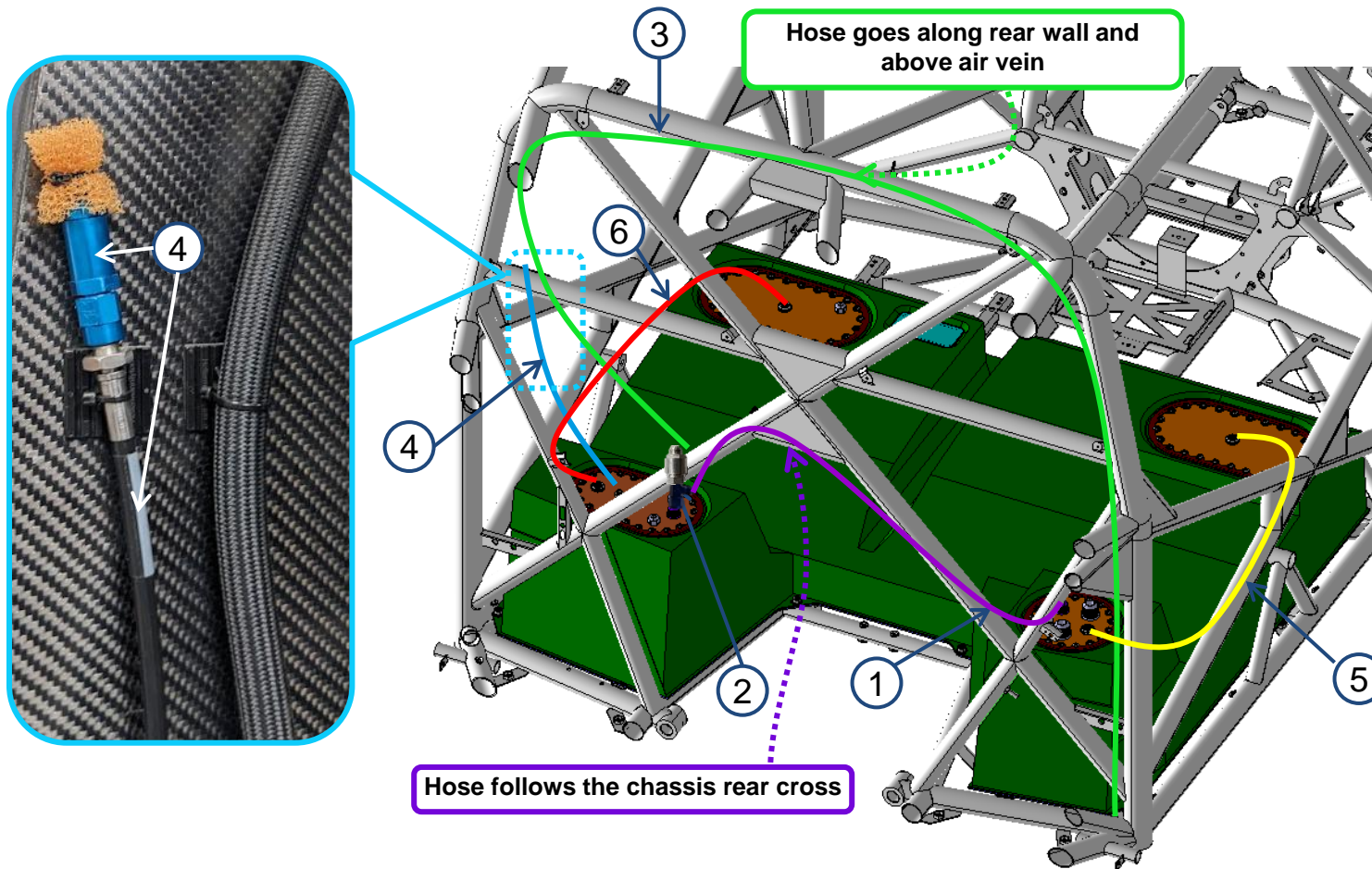

No.	Ref.	Name	Qty.
1	4020083	COP-HOSE RIGHT LEFT REAR VENT JUNCTION - L1160MM	1
2	4014145	COP-VALVE FIA VENT AND NO RETURN VALVE	1
3	4016491	COP-HOSE VENTING LG: 3330MM	1
4	4016494	COP-HOSE TO PRESSURE RELIEF VALVE 200MB LG:780MM	1
5	4020074	COP-HOSE FRONT TO REAR RIGHT FUEL TANK VENTING - L900MM	1
6	4020075	COP-HOSE FRONT TO REAR LEFT FUEL TANK VENTING - L980MM	1

## 4.4 FUEL STORAGE – Fuel Tank Pressure Relief for composite fuel tank

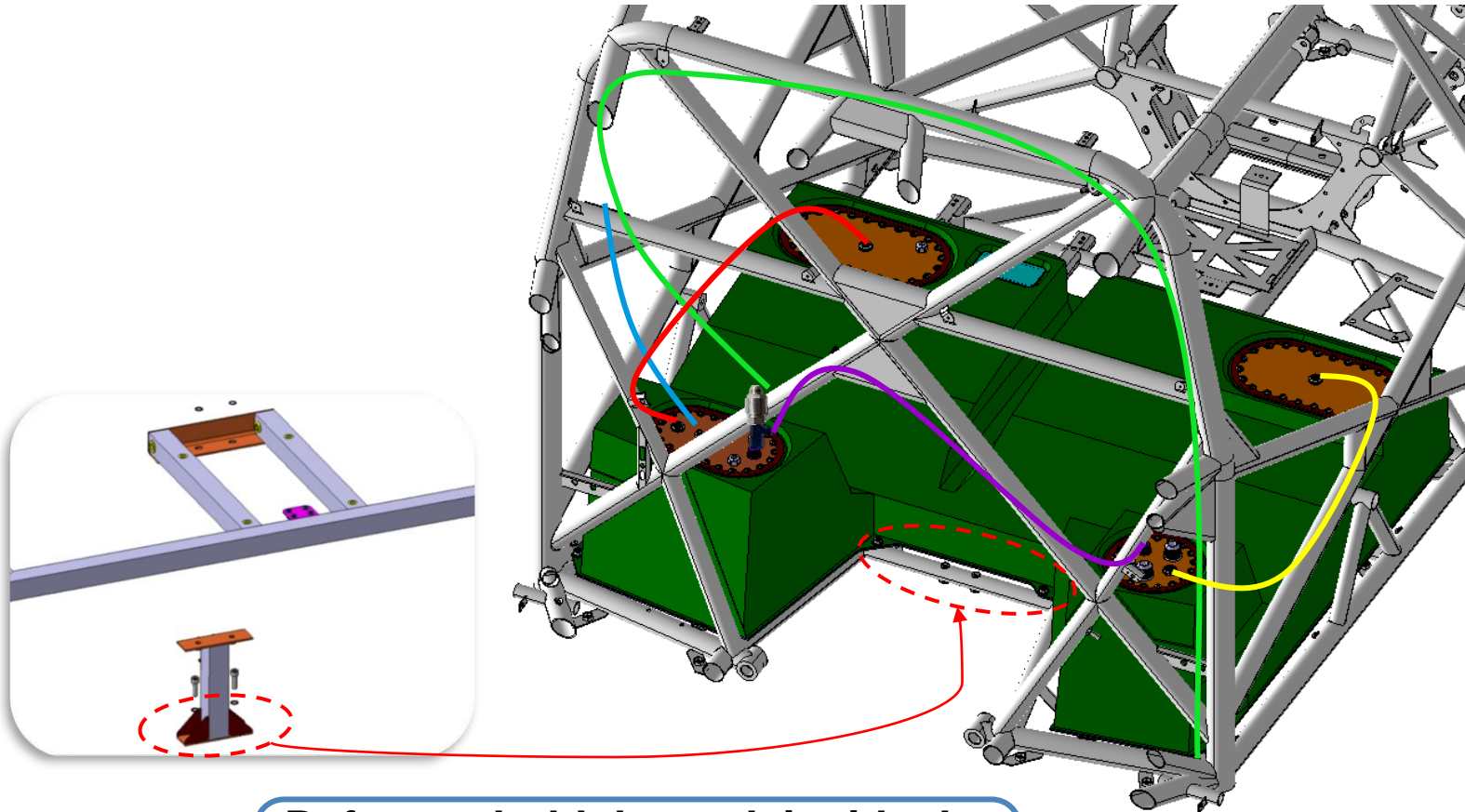

**Before to hold the tank inside the body, check if those parts fit together (4020380 & 4019999)**

## 4.5.1 FUEL STORAGE – Fuel Filling

All fuel tank

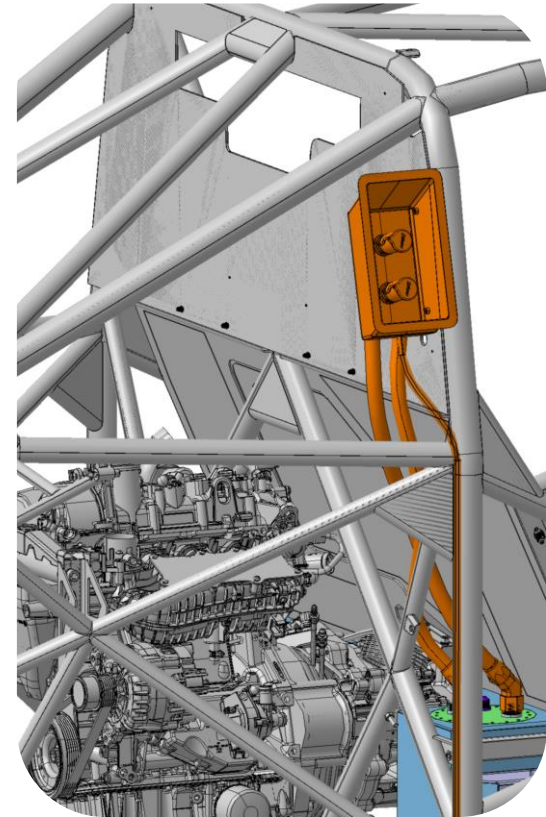
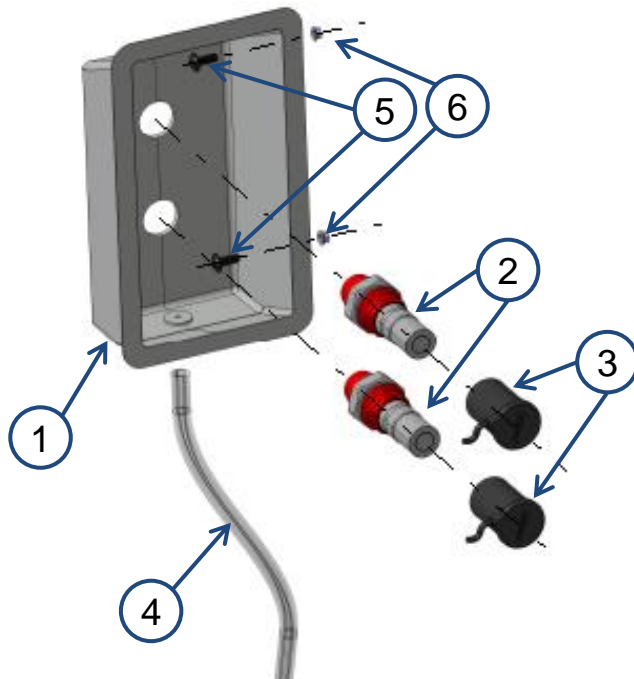

**Add 2 ty-raps around the chassis tube to improve rigidity**

No.	Ref.	Name	Qty.
1	4014362	DRP-COMPONENT FUEL FILLER RECEPTACLE	1
2	4012726	COP-CONNECTOR STAUBLI SPT 12.5658/LJV	2
3	4012728	COP-CAP STAUBLI SPT12.8550	2
4	4015287	DRP-HOSE TEFLON - L = 918MM	1
5	4013534	COP – SCREW BUTTON HEAD WITH FLANGE – M6X16 –CL10,9 – BLACK	2
6	4013685	SUP-LOCKNUT WITH FLANGE - M6X1.00 - SIMMONDS	2



## 5.5.2 FUEL STORAGE – Fuel Filling

All fuel tank

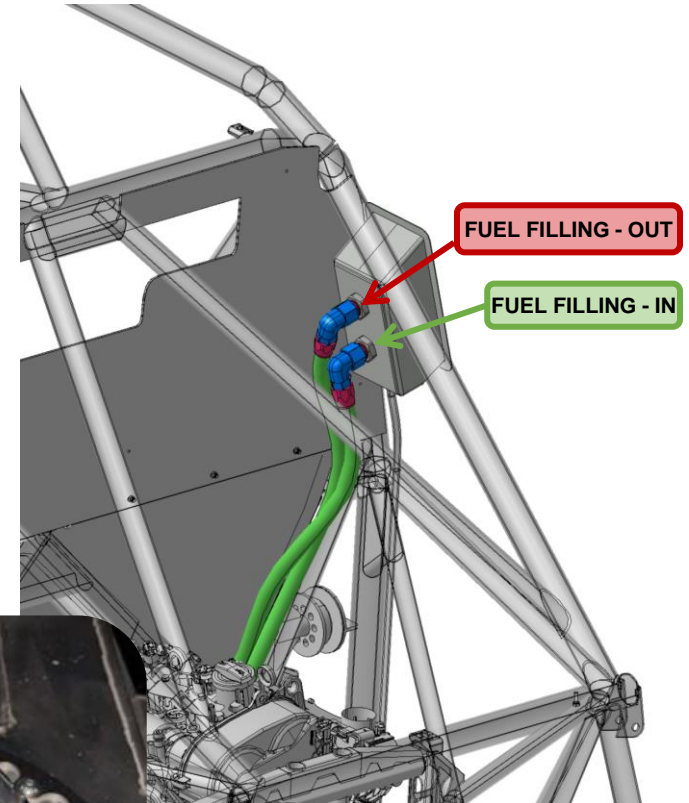
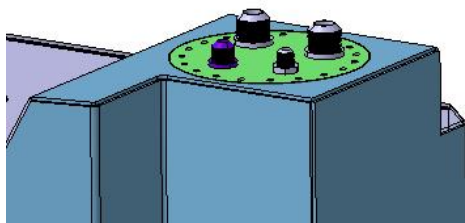
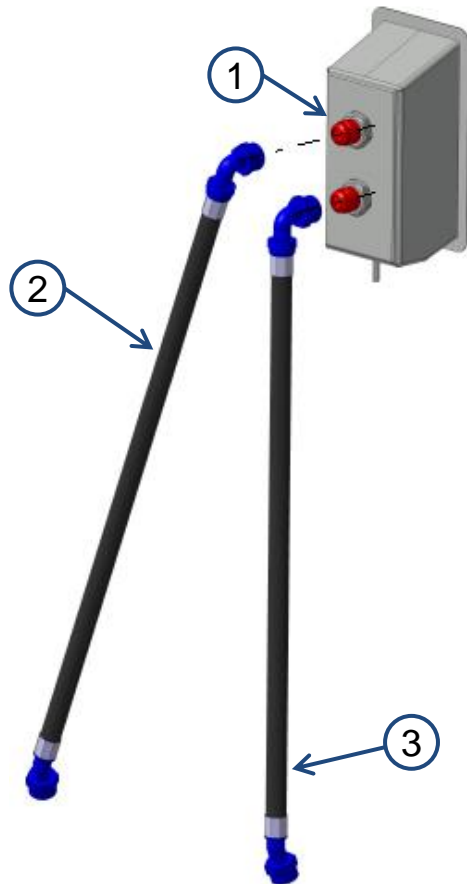

No.	Ref.	Name	Qty.
1	4015250	SASS – FUEL FILLER RECEPTACLE	1
2	4016489	COP-HOSE REFUEL VENT L 800MM	1
3	4016488	COP HOSE REFUEL IN ASSY L 730MM	1

# 4.6 FUEL STORAGE – Fuel Supply

All fuel tank

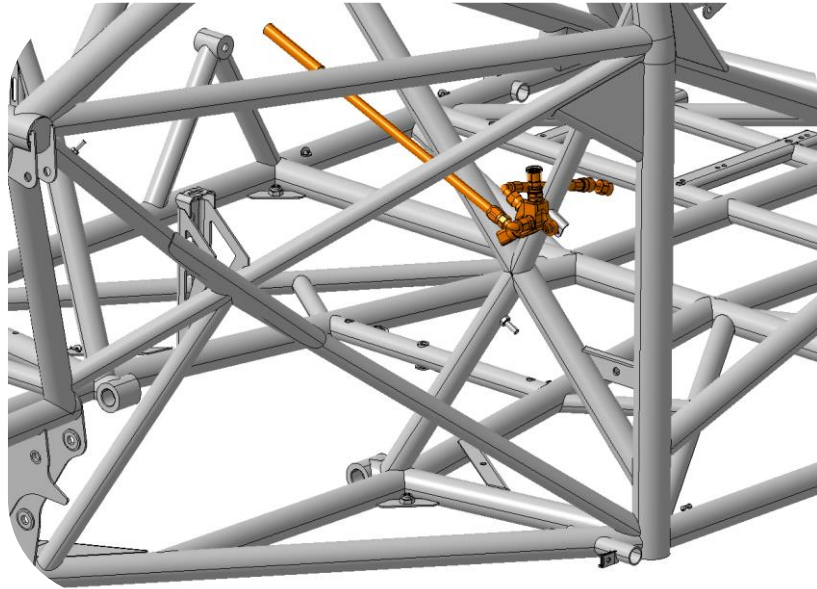
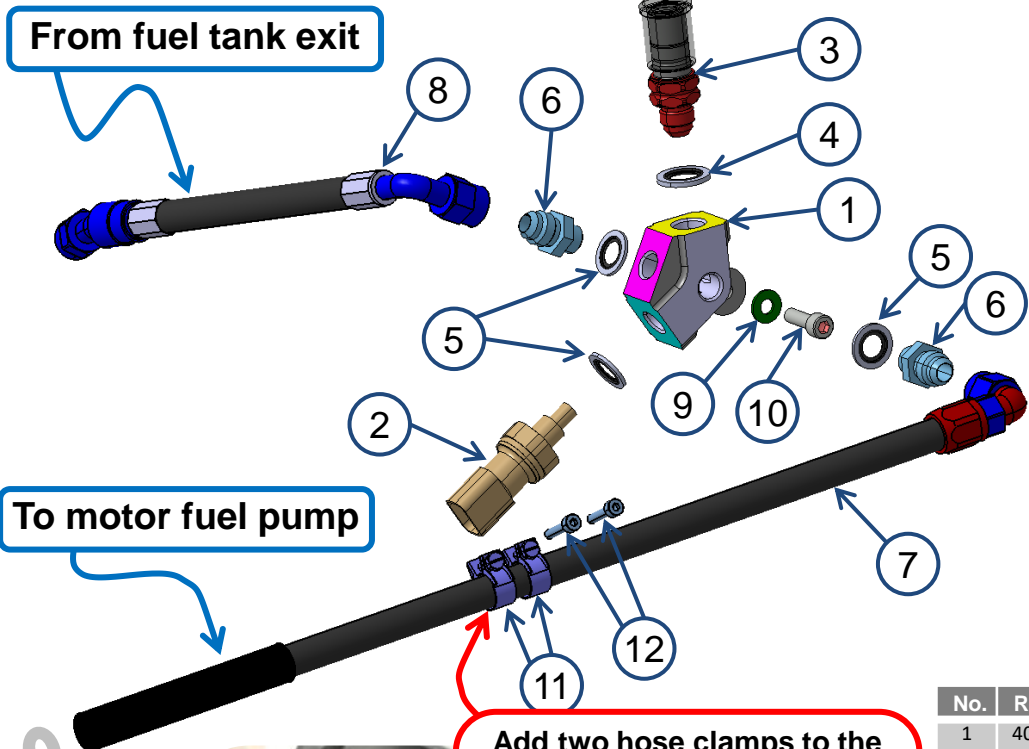

**Add two hose clamps to the hose. These clamps are to be used for fast reparation during races. Original flat head screw must be replaced with hexagonal socket screws**

**Final hose clamp must be secured to motor with lockwire**

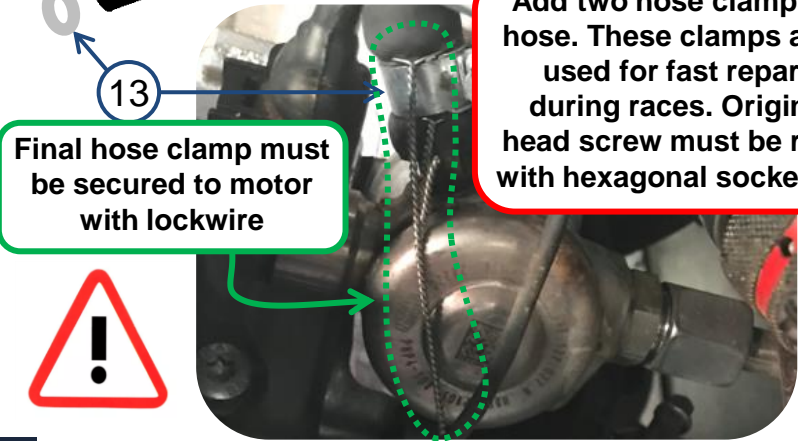

No.	Ref.	Name	Qty.
1	4014583	DRP-CONNECTOR FUEL LINE	1
2	4011768	COP-SENSOR PRESSURE + TEMPERATURE - M12X125	1
3	4013722	COP-CONNECTOR FIA FUEL SAMPLING - DASH-6 - SPT08 – ALU	1
4	4013814	SUP-PLAIN WASHER COMPOSITE	1
5	4013730	SUP-PLAIN WASHER COMPOSITE	3
6	4013729	COP-ADAPTER ALU	2
7	4016493	COP-HOSE DISTRIBUTOR TO ENGINE HP FUEL PUMP LG:465 MM	1
8	4016492	COP-HOSE HP OUT TO DISTRIBUTOR LG:235 MM	1
9	4000936	STD-SUP-HEXAGONAL SOCKET CAP SCREW	1
10	4009165	STD-SUP-PLAIN WASHER	1
11	4014699	STD – SUP - HOSE CLAMP	2
12	010386	MCE-SUP-HEXAGONAL SOCKET CAP SCREW	2
13	4017895	MCE-SUP-HOSE CLAMP	1

## Section 5

### Powertrain

# 5.1 POWERTRAIN – Engine

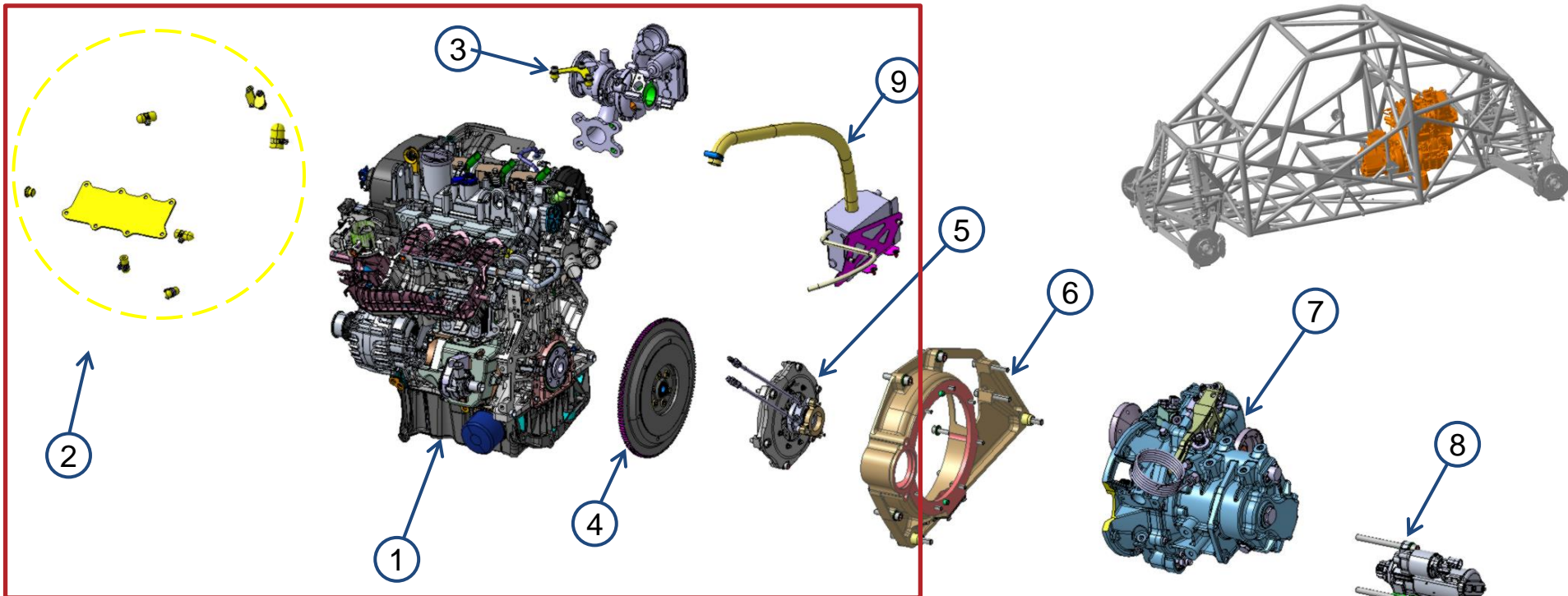

No.	Ref.	Name	Qty.
1	4014537	ASS - SHORT ENGINE VW 1.0L TSI EA211 3 CYLINDERS	1
2	4014443	SASS-ENGINE PLUGS	1
3	4014428	SASS-TURBOCHARGER EQUIPPED	1
4	4012404	SASS-FLYWHEEL VW 1.0L TSI	1
5	4012644	SASS-CLUTCH SIMPLE DISK - 7.25 INCHES (TILTON)	1
6	4012376	SASS-CLUTCH HOUSING EQUIPPED	1
7	4013642	ASS-GEARBOX COMPLETE	1
8	4012393	SASS-ENGINE STARTER	1
9	4014189	SASS – DECANTER EQUIPPED	1

# 5.5.1 POWERTRAIN – Engine – Ignition and sensors – 2023 SPEC (ECUMASTER PDM)

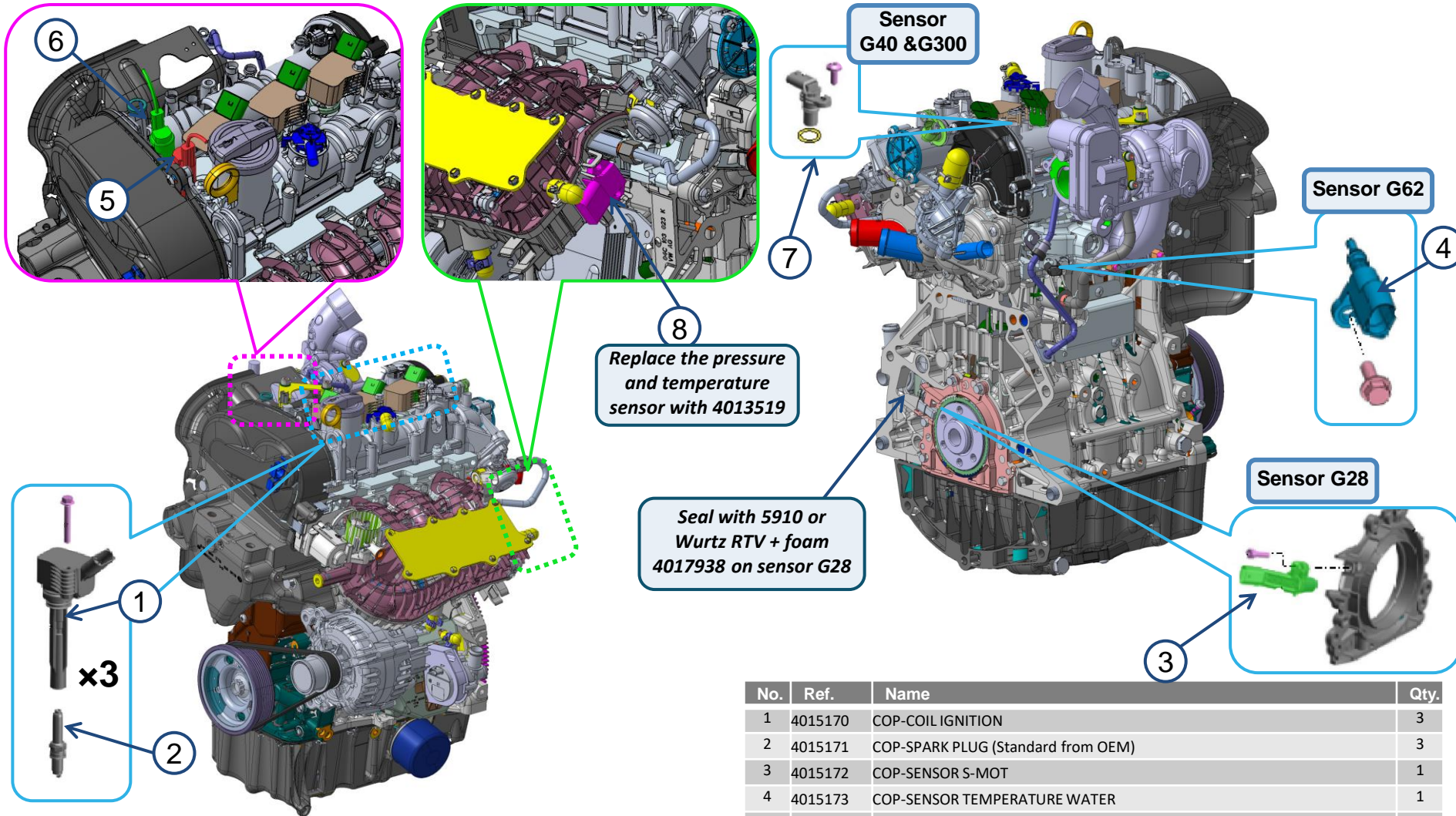

**Assembly Tips:**

- Put some silicone grease on coils
- Identify on coil the cylinder N° corresponding

No.	Ref.	Name	Qty.
1	4015170	COP-COIL IGNITION	3
2	4015171	COP-SPARK PLUG (Standard from OEM)	3
3	4015172	COP-SENSOR S-MOT	1
4	4015173	COP-SENSOR TEMPERATURE WATER	1
5	4016573	SASS-WIRING VVT INTAKE	1
6	4016574	SASS-WIRING VVT EXHAUST	1
7	4015541	COP-SENSOR S-CAM	2
8	4013519	COP-SENSOR TEMPERATURE & PRESSURE 4 BARS	1

# 5.5.2 POWERTRAIN – Engine – Ignition and sensors – 2024 SPEC (HP 8442 PDM)

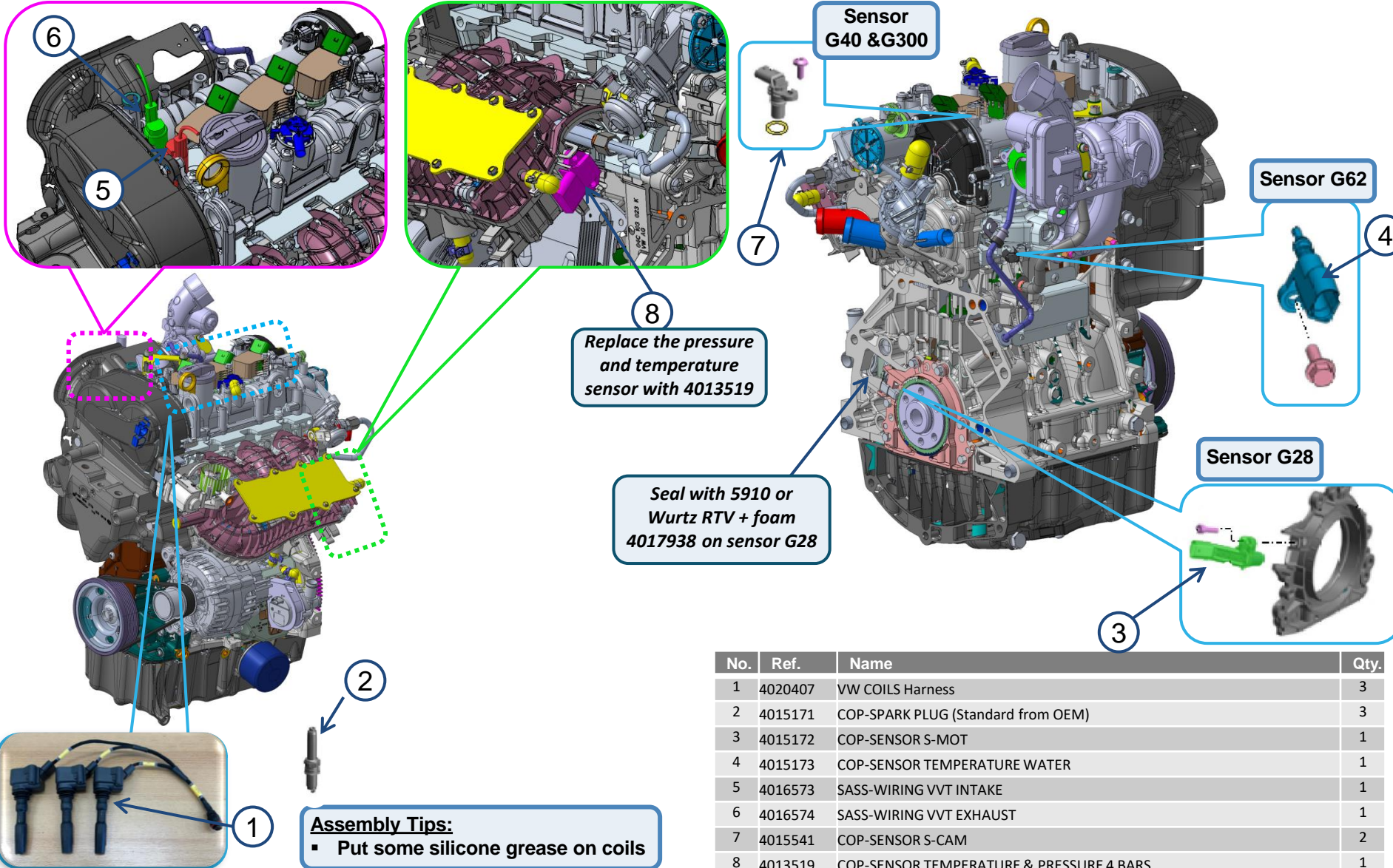

No.	Ref.	Name	Qty.
1	4020407	VW COILS Harness	3
2	4015171	COP-SPARK PLUG (Standard from OEM)	3
3	4015172	COP-SENSOR S-MOT	1
4	4015173	COP-SENSOR TEMPERATURE WATER	1
5	4016573	SASS-WIRING VVT INTAKE	1
6	4016574	SASS-WIRING VVT EXHAUST	1
7	4015541	COP-SENSOR S-CAM	2
8	4013519	COP-SENSOR TEMPERATURE & PRESSURE 4 BARS	1

# 5.7 POWERTRAIN – Intake line adapter pipe

All intercoolers



To facilitate vehicle assembly, the following element can be fitted on the plenum during sub assembly:

- #1
- #2
- #3

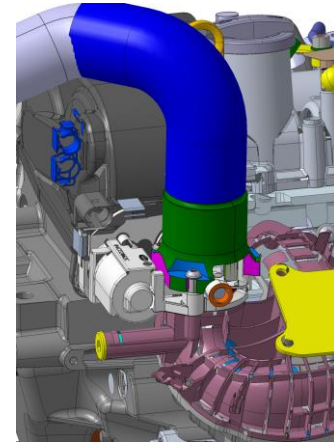
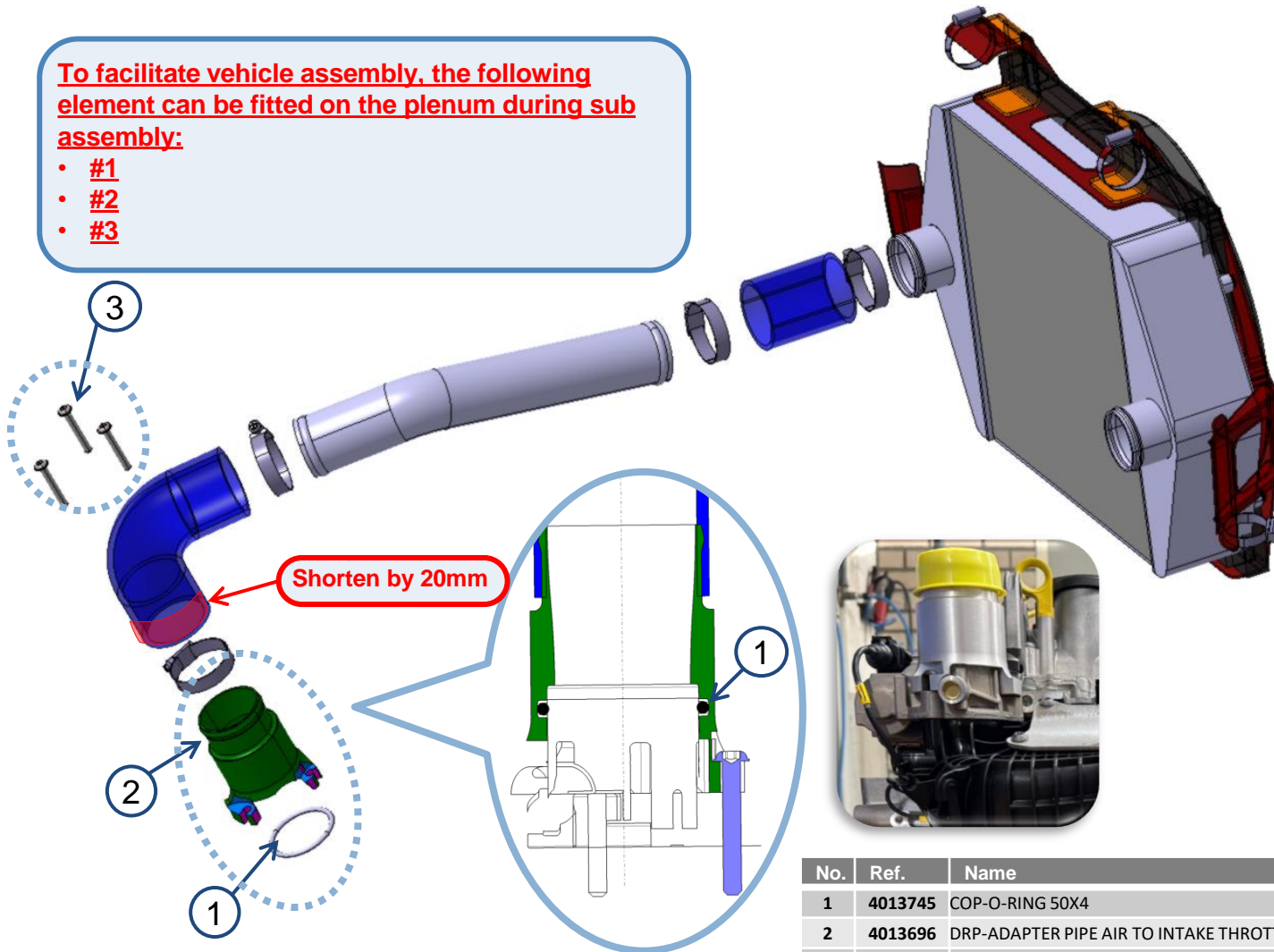

No.	Ref.	Name	Qty.
1	4013745	COP-O-RING 50X4	1
2	4013696	DRP-ADAPTER PIPE AIR TO INTAKE THROTTLE CANAM	1
3	4021800	COP-HOSE CLAMP WURTZ 14,3MM 40-60 MM	4

# 5.8 POWERTRAIN – Flywheel

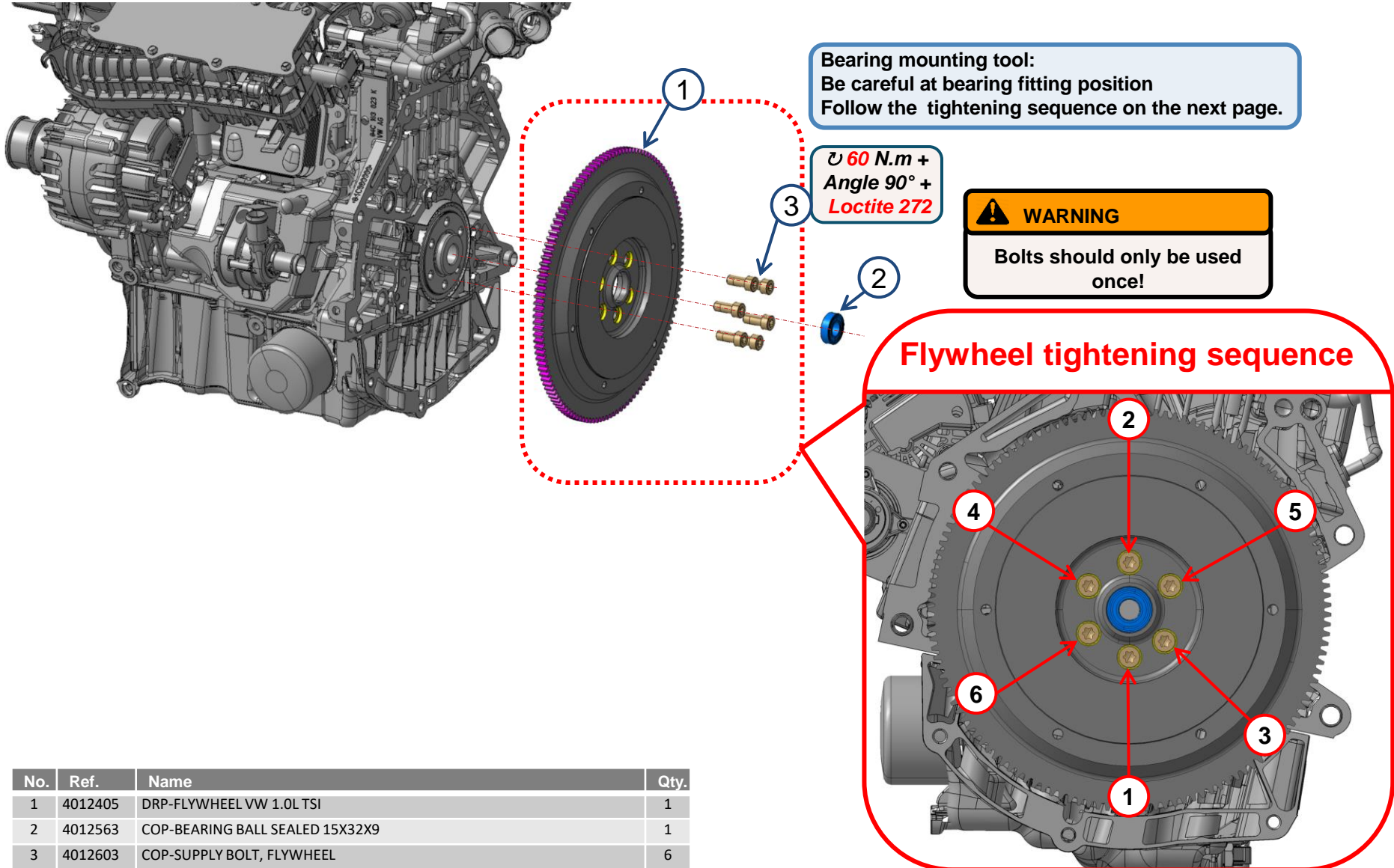

No.	Ref.	Name	Qty.
1	4012405	DRP-FLYWHEEL VW 1.0L TSI	1
2	4012563	COP-BEARING BALL SEALED 15X32X9	1
3	4012603	COP-SUPPLY BOLT, FLYWHEEL	6



## 5.9.1 POWERTRAIN – Clutch – Simple Disk – 7.25 Inches (Tilton)

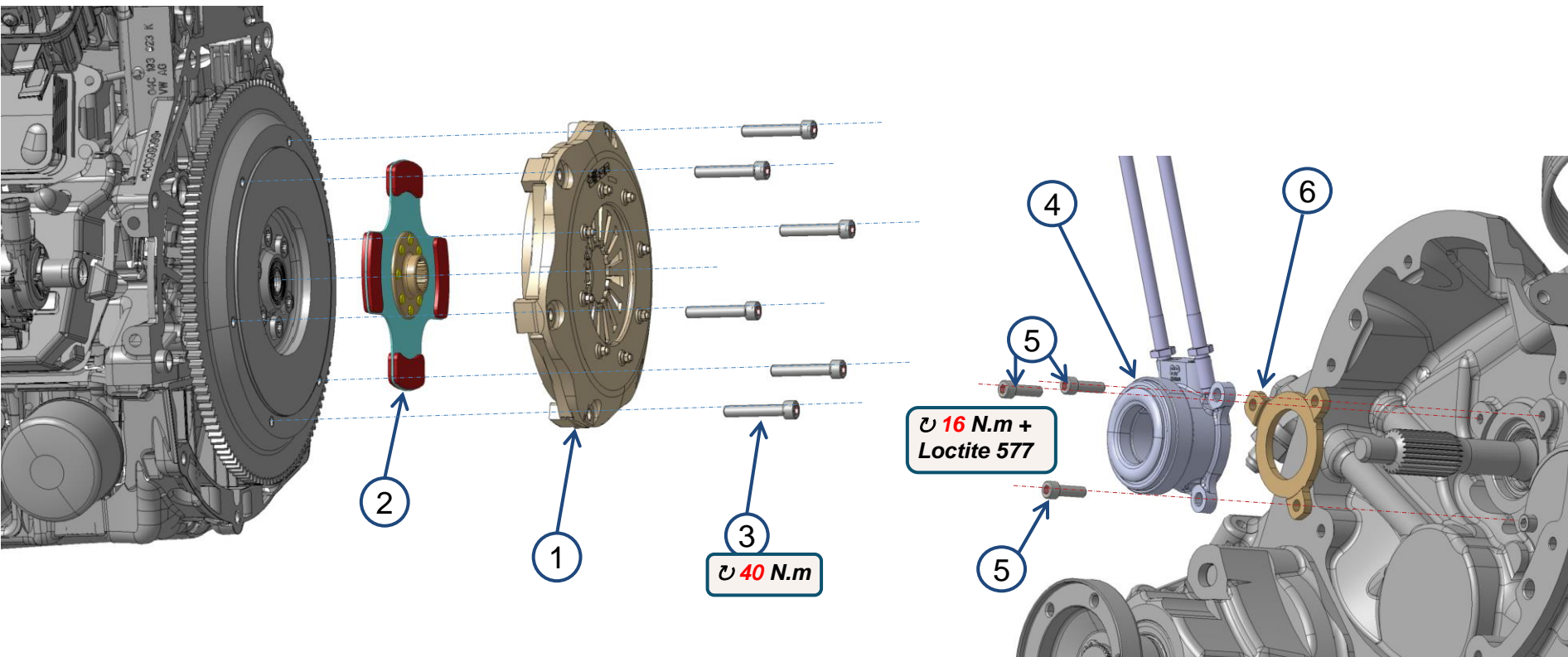

No.		Number-Version-Name	Qty.
1	4012645	COP-CLUTCH - SIMPLE DISC - 7.25 INCH	1
2	4012647	COP - CLUTCH DISKS	1
3	4000621	SUP-HEXAGONAL SOCKET CAP SCREW	6
4	4012956	COP - CLUTCH RELEASE	1
5	4000588	SUP-HEXAGONAL SOCKET CAP SCREW	3
6	4012965	COP-CLUTCH BEARING SPACER – 10 MM	1

## 5.9.2 POWERTRAIN – Clutch – Double Disk – 7.25 Inches (Tilton)

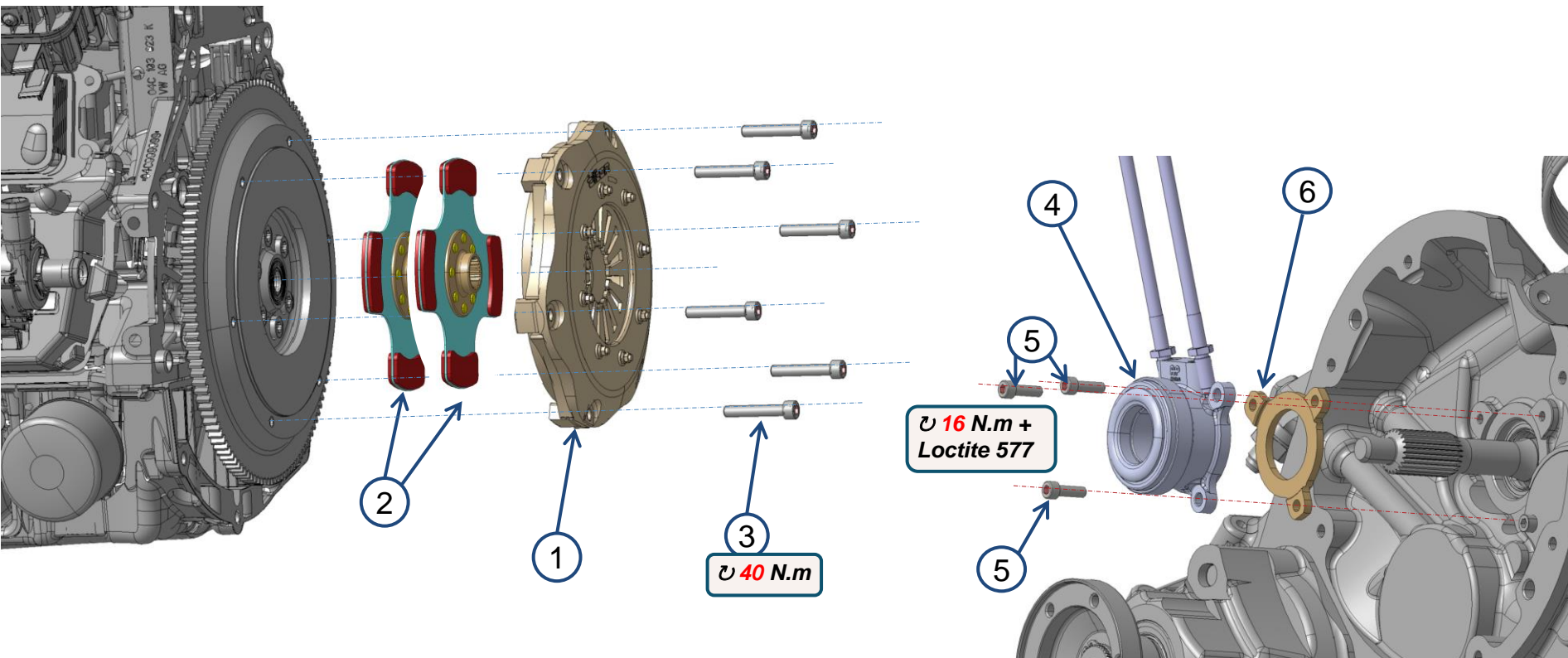

No.		Number-Version-Name	Qty.
	4019626	SASS-CLUTCH 7.25 INCHES - METALLIC - DOUBLE DISKS - 762 NM	1
1	4019625	COP-CLUTCH - DOUBLE DISKS STACKED - 7.25 INCHES - 762 NM	1
2	4019624	COP-CLUTCH DISKS	2
	4013575	COP-WASHER Ø8 SCHNORR	6
3	4018641	DRP-SCREW M8	6
4	4012956	COP-CLUTCH RELEASE	1
	4014024	COP-WASHER	3
5	4000937	SUP-HEXAGONAL SOCKET CAP SCREW	3
	4012960	COP-CLUTCH BEARING SPACER - 4 MM	1

# 5.10.1 POWERTRAIN – Engine– 2024 Spec – Loom set-up

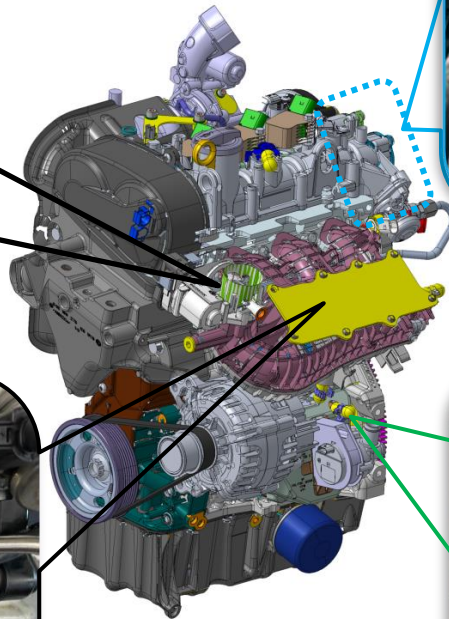
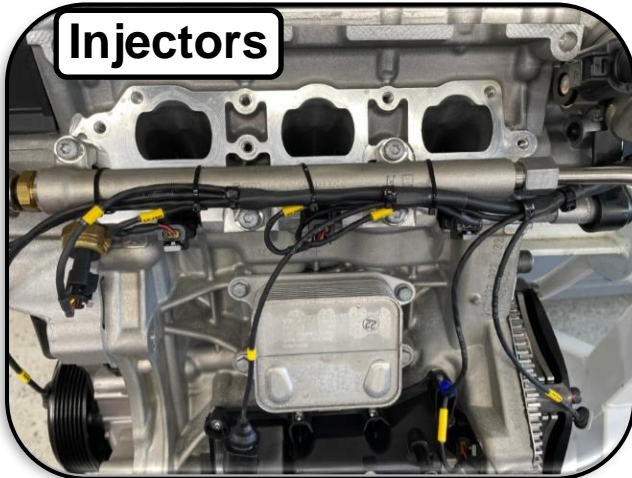
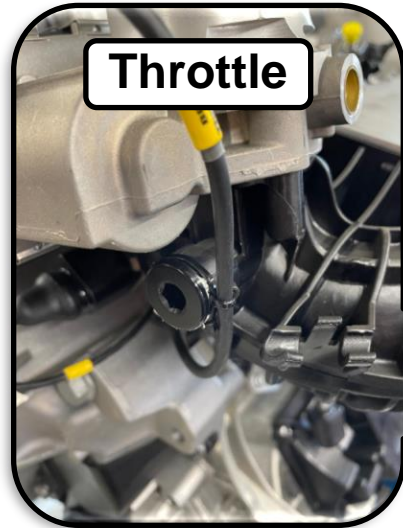

## 5.10.2 POWERTRAIN – Engine– 2024 Spec – Loom set-up

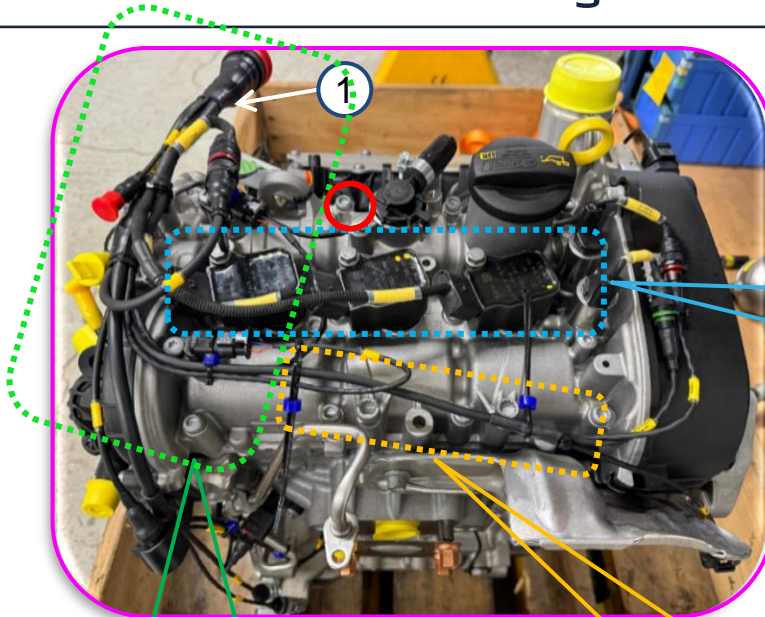

**Coils Ground**

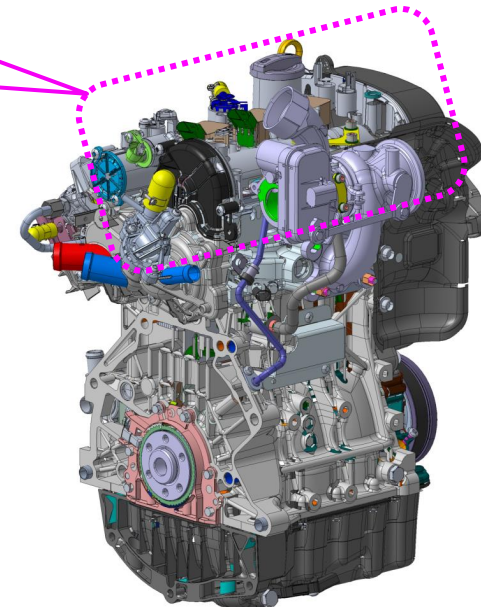

No.	Ref.	Name	Qty.
1	4018914	SASS HARNESS, VW Engine 2024	1
2	4020407	VW COILS Harness	1

# 5.10.3 POWERTRAIN – Engine– 2024 Spec – Loom set-up

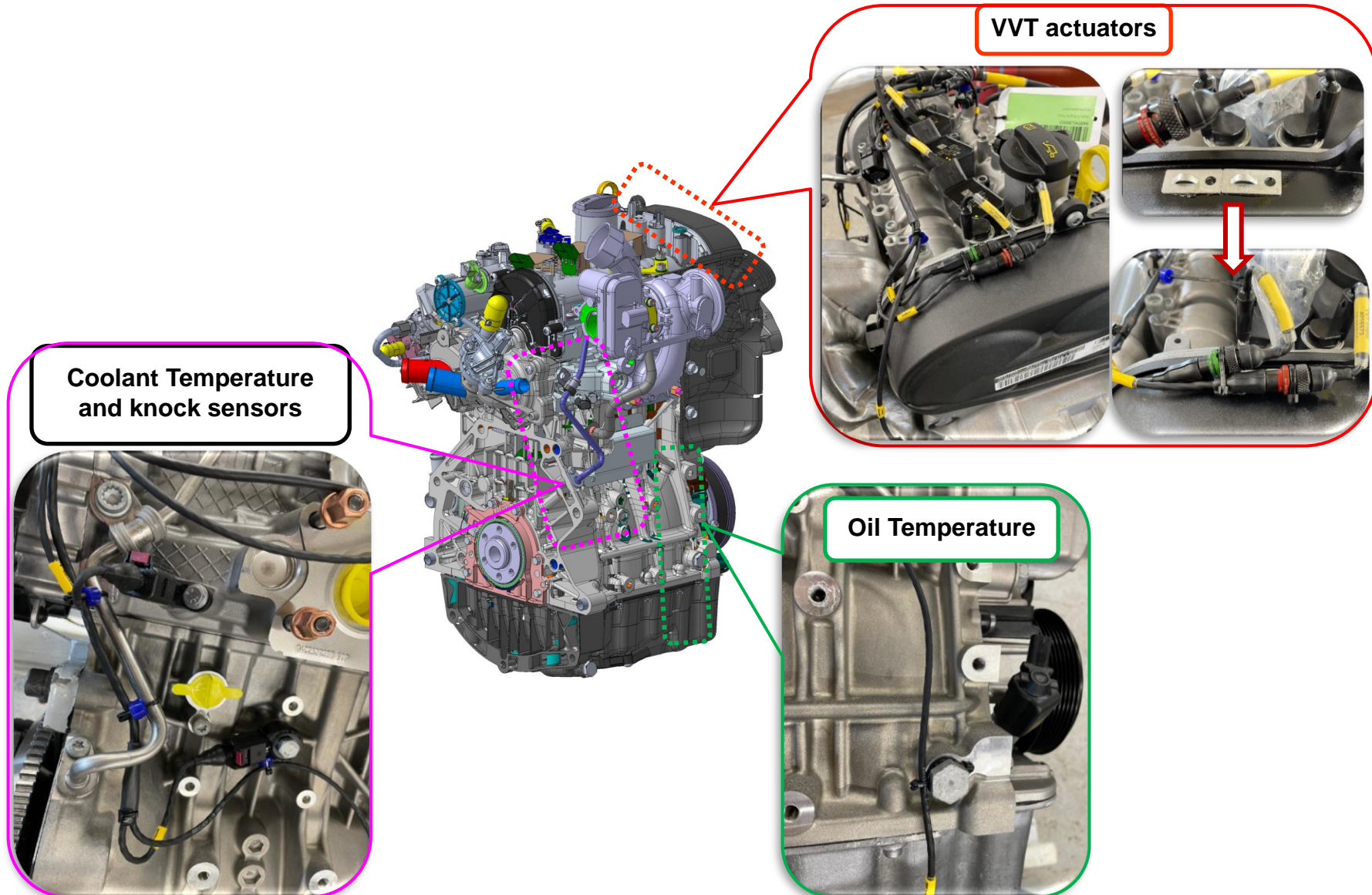

# 5.11 POWERTRAIN – Gearbox

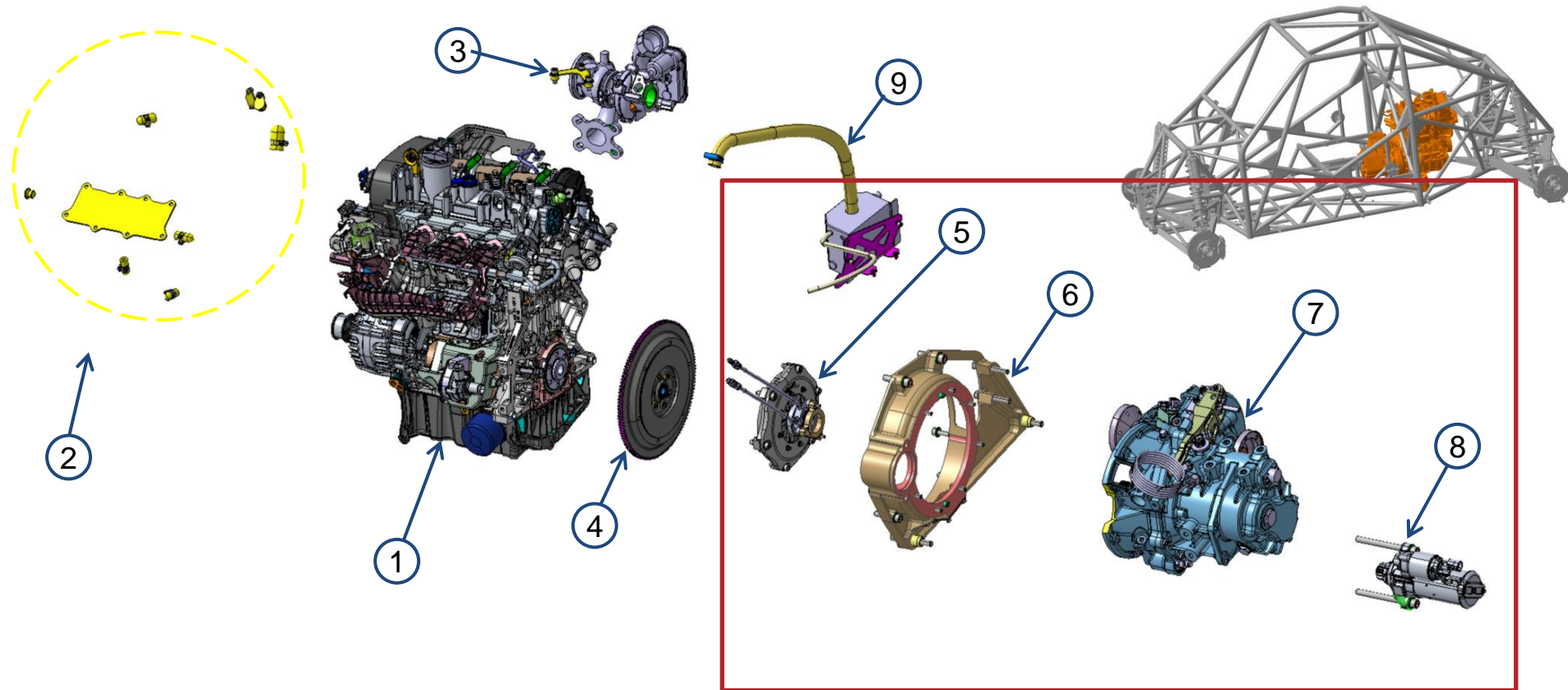

No.	Ref.	Name	Qty.
1	4014537	ASS - SHORT ENGINE VW 1.0L TSI EA211 3 CYLINDERS	1
2	4014443	SASS-ENGINE PLUGS	1
3	4014428	SASS-TURBOCHARGER EQUIPPED	1
4	4012404	SASS-FLYWHEEL VW 1.0L TSI	1
5	4012644	SASS-CLUTCH SIMPLE DISK - 7.25 INCHES (TILTON)	1
6	4012376	SASS-CLUTCH HOUSING EQUIPPED	1
7	4013642	ASS-GEARBOX COMPLETE	1
8	4012393	SASS-ENGINE STARTER	1
9	4014189	SASS – DECANter EQUIPPED	1

## 5.11.1 POWERTRAIN – Gearbox preparation

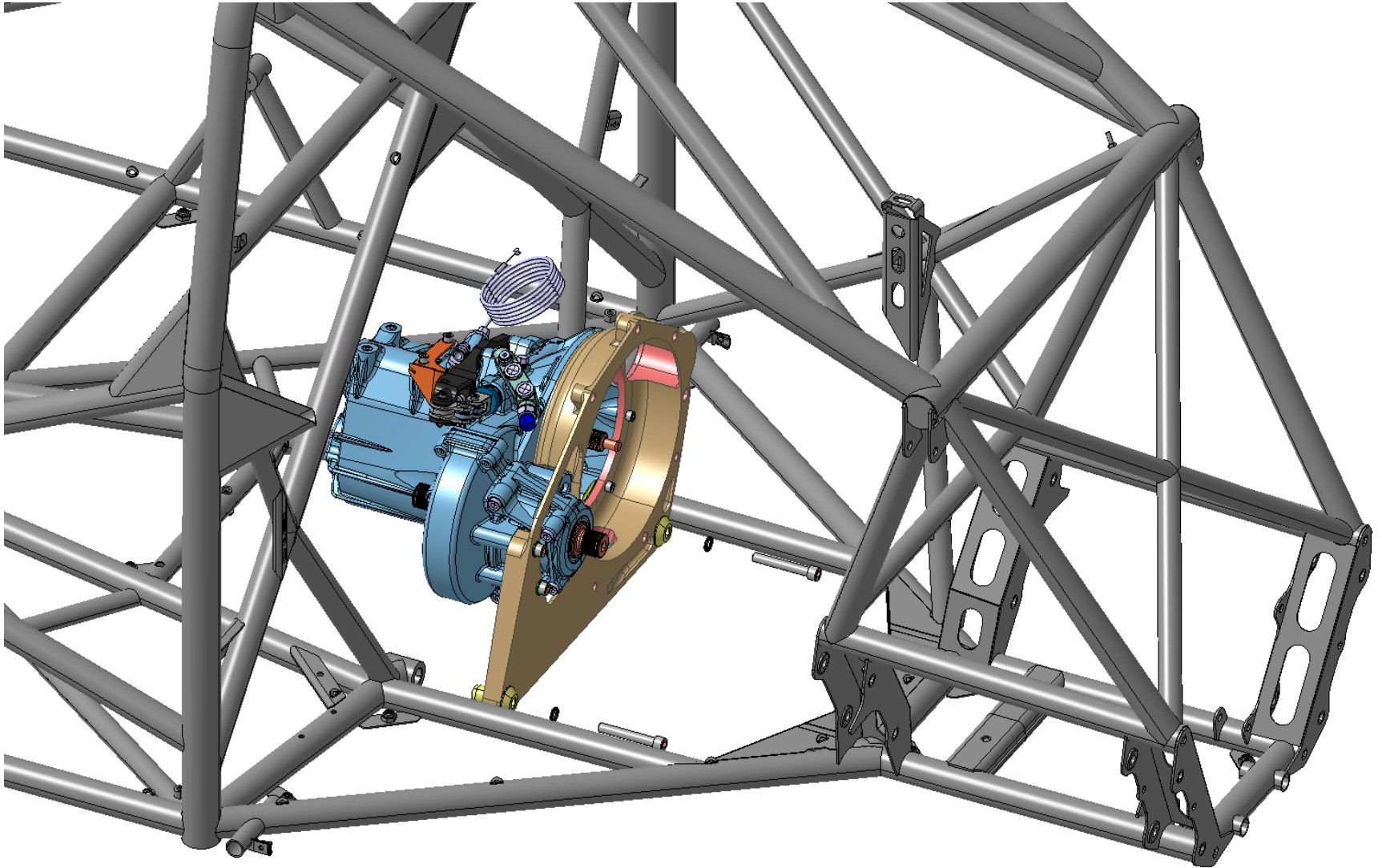

# 5.11.2 POWERTRAIN – Gearbox – Overview



## 3MO Performance Gear Box Assembly / Servicing Book

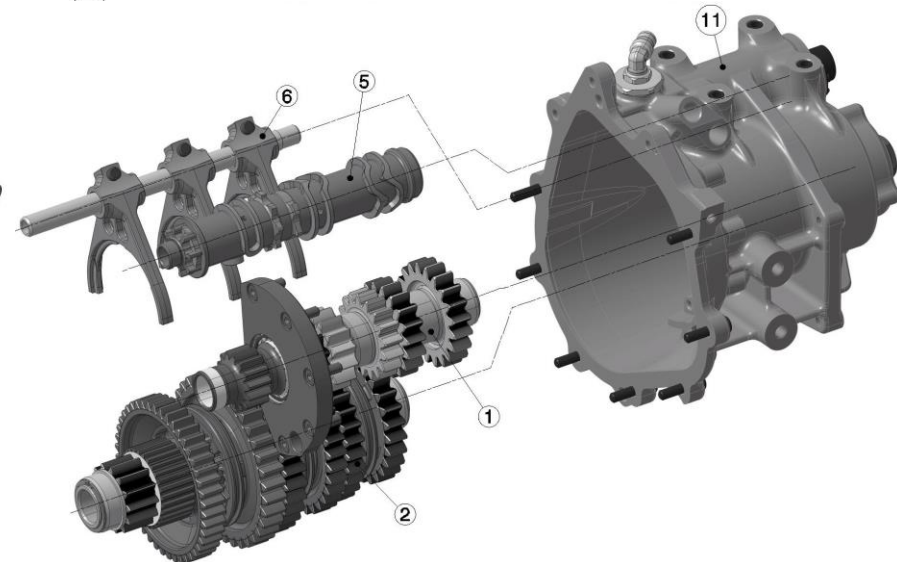
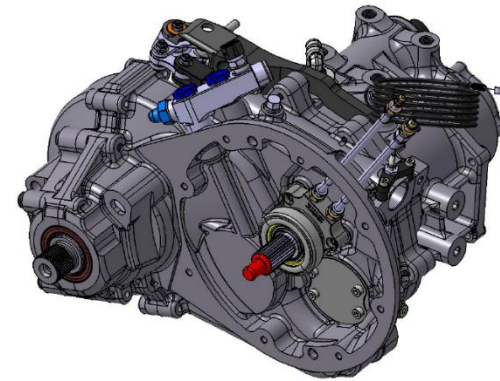
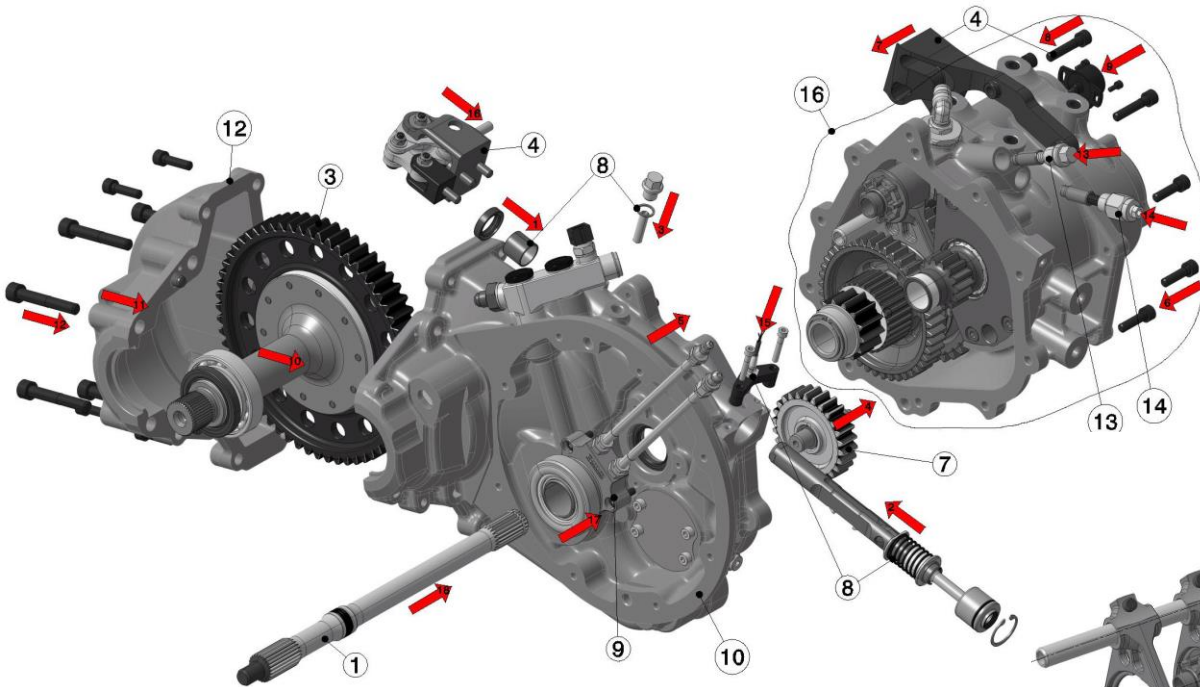

Following Document Ref:

[9038\\_Catalogue-BV-ETV-5V-Raid-STD -indA\\_\(3MO\).pdf](#)

No.	Ref.	Name	Qty.
1	4012295	COP-GEARBOX SEQUENTIAL 5 SPEEDS	1



# 5.11.3 POWERTRAIN – Gearbox – Overview

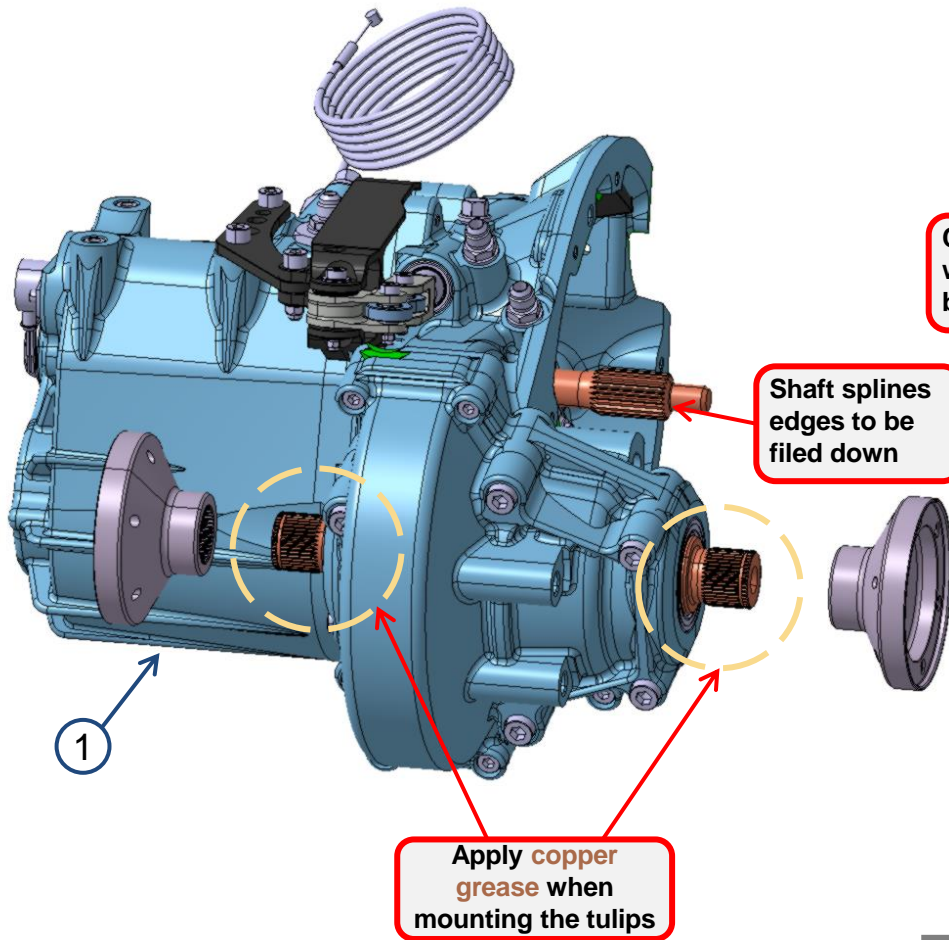

Clutch hoses window must be deburred

Installation details on slide :  
4.8.3 POWERTRAIN – Gearbox – Foam

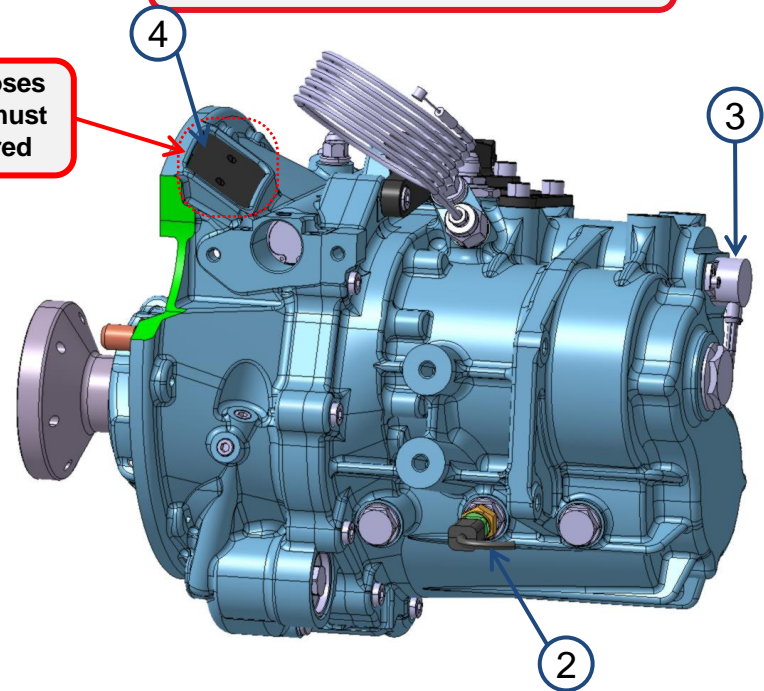

**PLEASE REFER TO THE FOLLOWING PAGES FOR DETAILED INSTRUCTIONS**

No.	Ref.	Name	Qty.
1	4012295	COP-GEARBOX SEQUENTIAL 5 SPEEDS →	1
-	4012564	DRP-GEARBOX HOUSING – REWORK	1
-	4012294	COP-TO BE DEFINED GEAR BOX TULIP FLANGE	2
2	4017096	COP-WIRING GEARBOX T°C	1
3	4016590	SASS-HARNESS SENSOR GEAR POSITON WIRING	1
4	4018071	DRP-FOAM CLUTCH HOSES WINDOW	1

# 5.11.4.1 POWERTRAIN – Gearbox – **without** internal oil pump

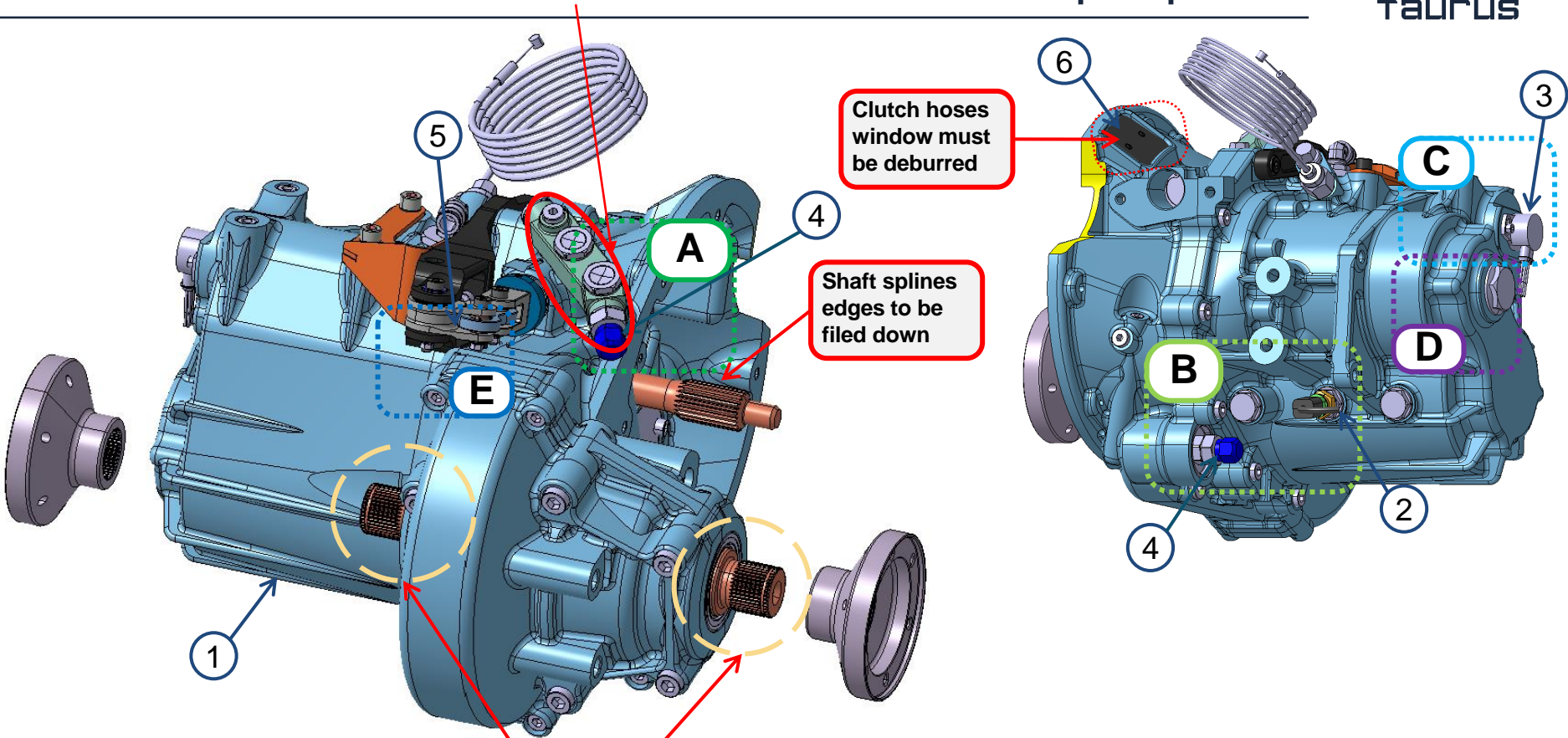

Clutch hoses window must be deburred

Shaft splines edges to be filed down

Apply copper grease when mounting the tulips

PLEASE REFER TO THE FOLLOWING PAGES FOR DETAILED INSTRUCTIONS

No.	Ref.	Name	Qty.
1	4012295	COP-GEARBOX SEQUENTIAL 5 SPEEDS →	1
-	4012564	DRP-GEARBOX HOUSING – REWORK	1
-	4012294	COP-TO BE DEFINED GEAR BOX TULIP FLANGE	2
2	4017096	COP-WIRING GEARBOX T°C	1
3	4016590	SASS-HARNES SENSOR GEAR POSITON WIRING4	
4	4016518	COP-PLUG ALUMIUM FEMALE SIMPLE JIC 9/16 X 18 - DASH 6	2
5	4013685	COP-NUT M6X100 SIMMONDS	4
6	4018071	DRP-FOAM CLUTCH HOSES WINDOW	1

## 5.11.4.2 POWERTRAIN – Gearbox – Overview – Gear box **with** internal oil pump

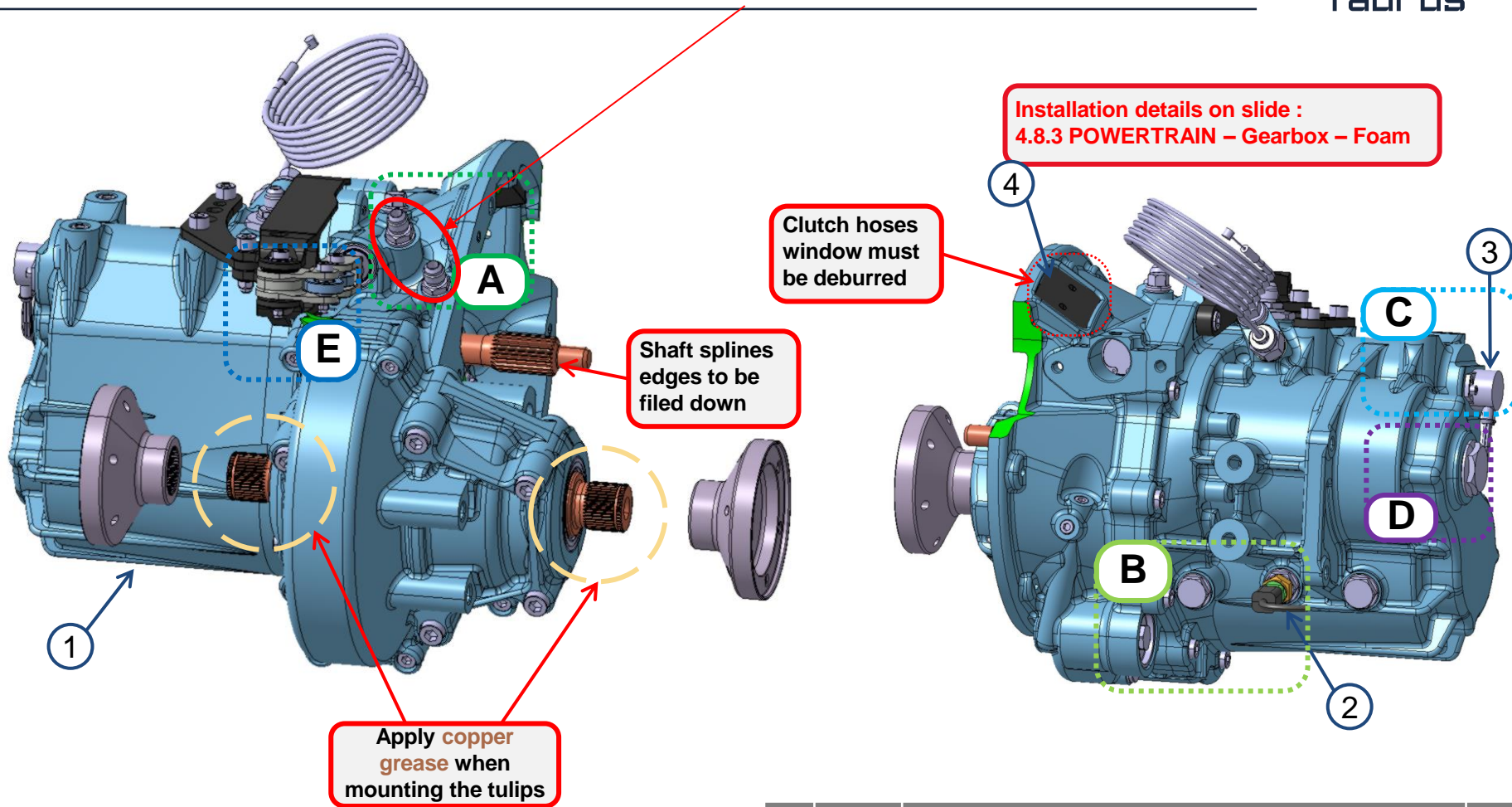

No.	Ref.	Name	Qty.
1	4012295	COP-GEARBOX SEQUENTIAL 5 SPEEDS →	1
-	4012564	DRP-GEARBOX HOUSING – REWORK	1
-	4012294	COP-TO BE DEFINED GEAR BOX TULIP FLANGE	2
2	4017096	COP-WIRING GEARBOX T°C	1
3	4016590	SASS-HARNES SENSOR GEAR POSITON WIRING	1
4	4018071	DRP-FOAM CLUTCH HOSES WINDOW	1

# 5.11.5.1 – GEARBOX PREPARATION – Plugs and Temperature and Gear position sensors

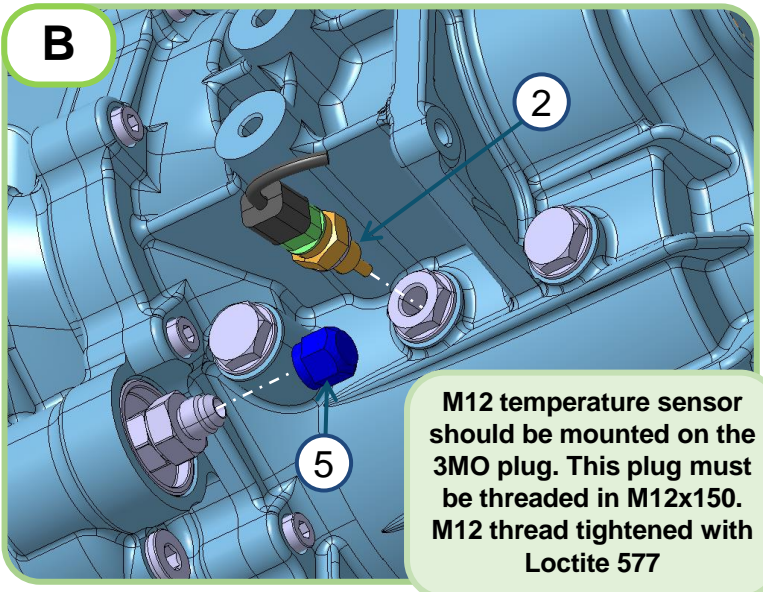
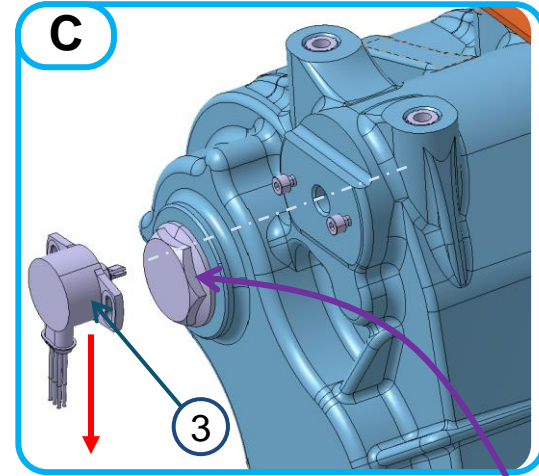
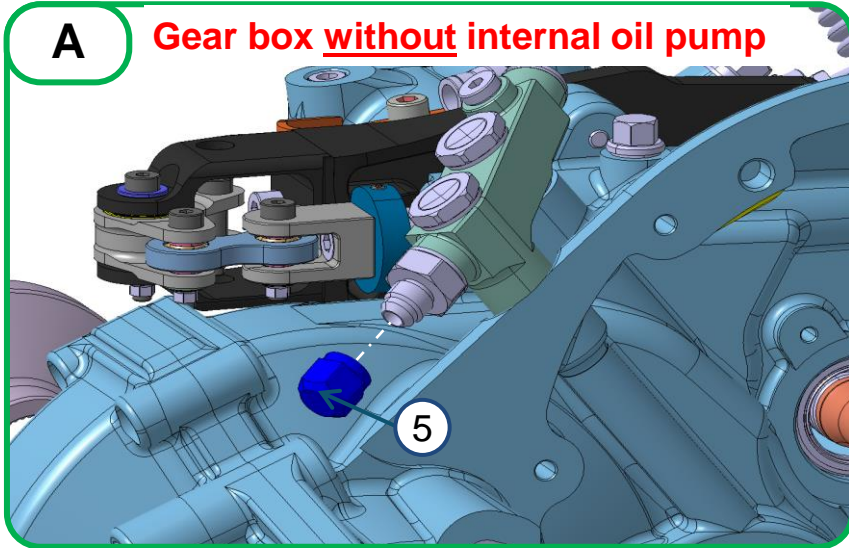

M12 temperature sensor should be mounted on the 3MO plug. This plug must be threaded in M12x150. M12 thread tightened with Loctite 577



REMOVE THE GEARBOX CAP (it will be reinstalled later, after fixing the gearbox to the motor)

No.	Ref.	Name	Qty.
2	4017096	COP-WIRING GEARBOX T°C	1
3	4016590	SASS-HARNESS SENSOR GEAR POSITON WIRING	1
5	4016518	COP-PLUG ALUMIUM FEMALE SIMPLE JIC 9/16 X 18 - DASH 6	2

## 5.11.5.2 – GEARBOX PREPARATION – Plugs and Temperature and Gear position sensors

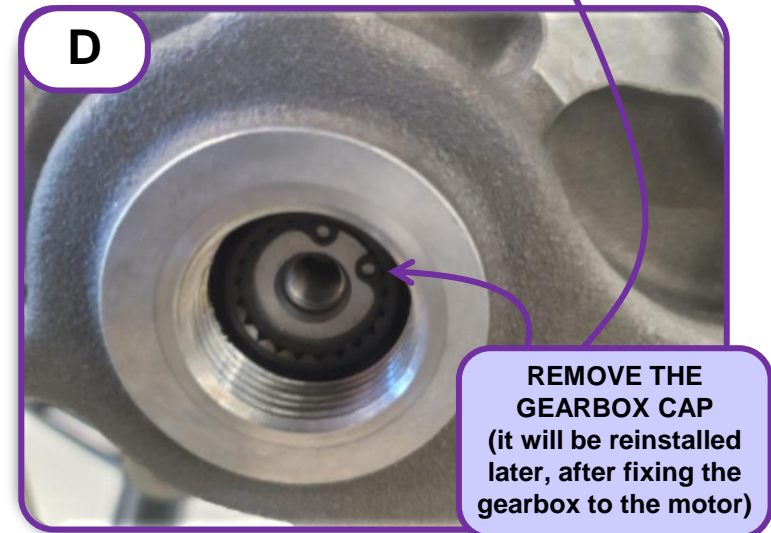
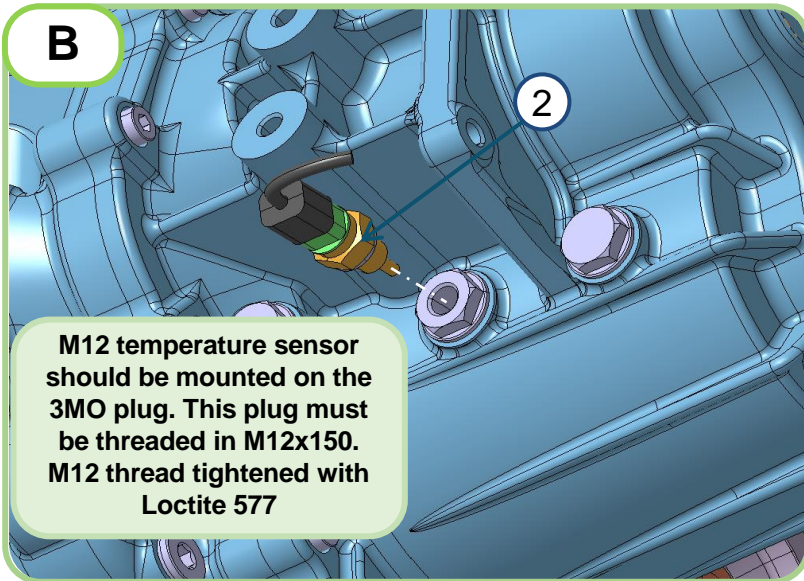
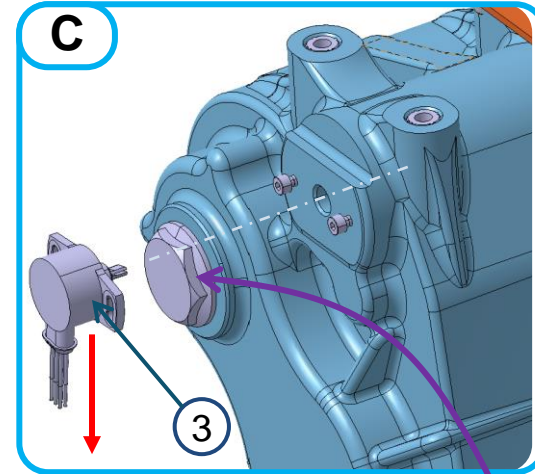
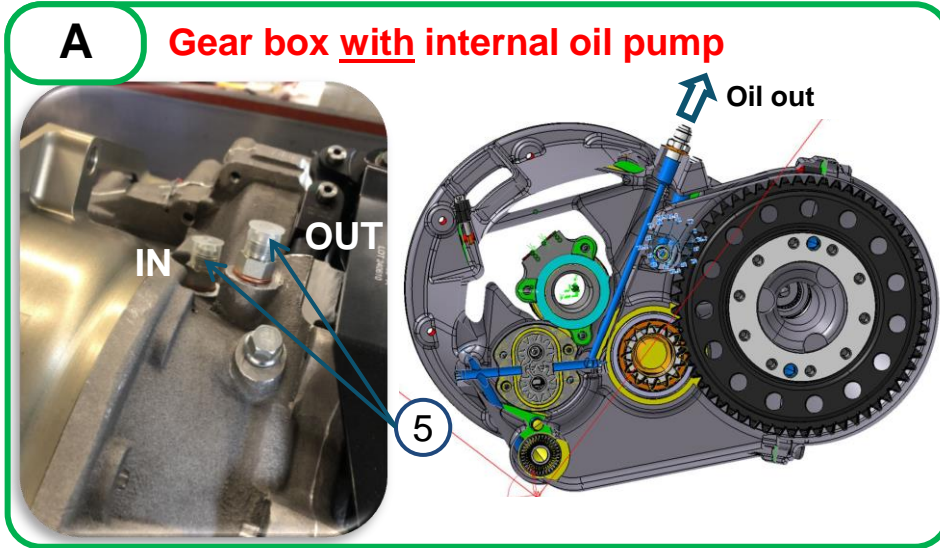

No.	Ref.	Name	Qty.
2	4017096	COP-WIRING GEARBOX T°C	1
3	4016590	SASS-HARNESS SENSOR GEAR POSITON WIRING	1
5	4016518	COP-PLUG ALUMIUM FEMALE SIMPLE JIC 9/16 X 18 - DASH 6	2

## 5.11.6 – GEARBOX PREPARATION – External rocker preparation

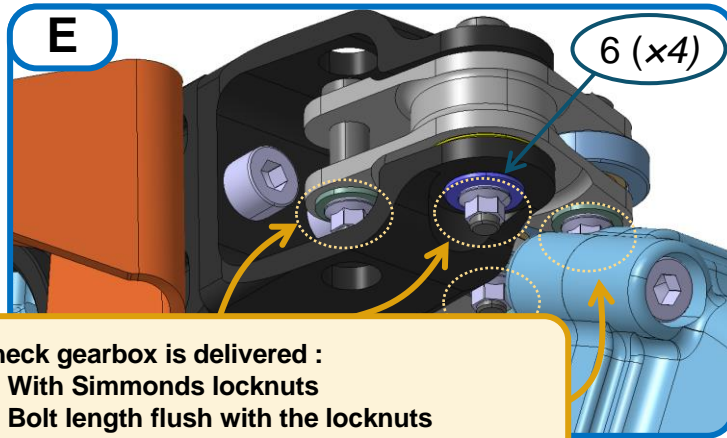

Check gearbox is delivered :

- With Simmonds locknuts
- Bolt length flush with the locknuts

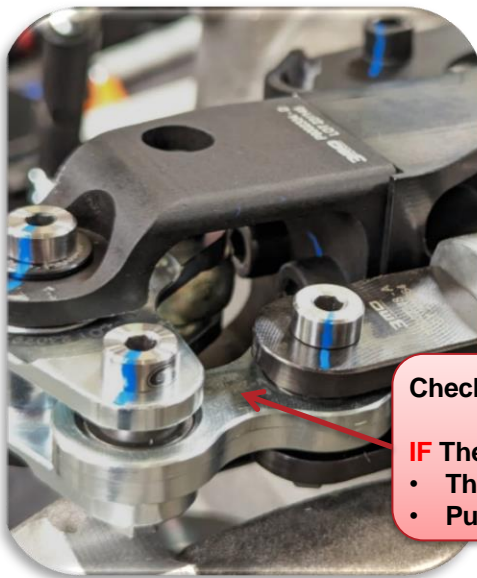
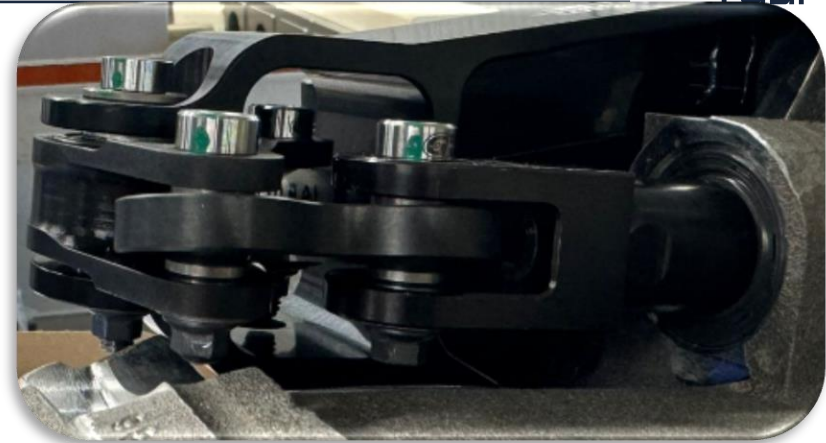

Check the number must **NOT** be visible

**IF** The link must be dismantled to check :

- The rose joints are properly glue, if not use Loctite 271
- Punch the rose joint to avoid any easy disassembled

When assembling, check that the screw does not touch the reworked part of the gearbox

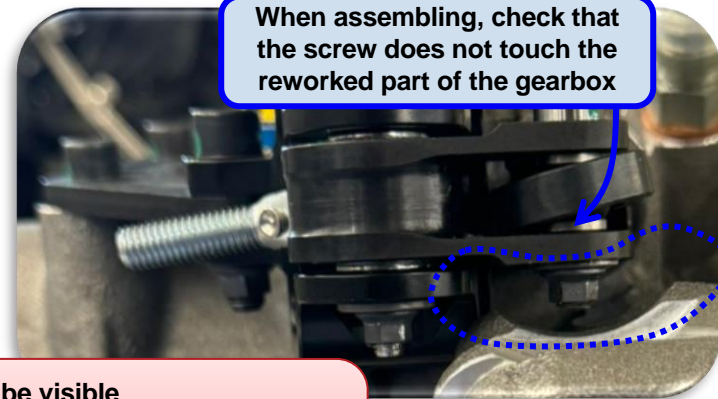

No.	Ref.	Name	Qty.
6	4013685	COP-NUT M6X100 SIMMONDS	4

## 5.11.8 – GEARBOX PREPARATION – Clutch – Set up parts

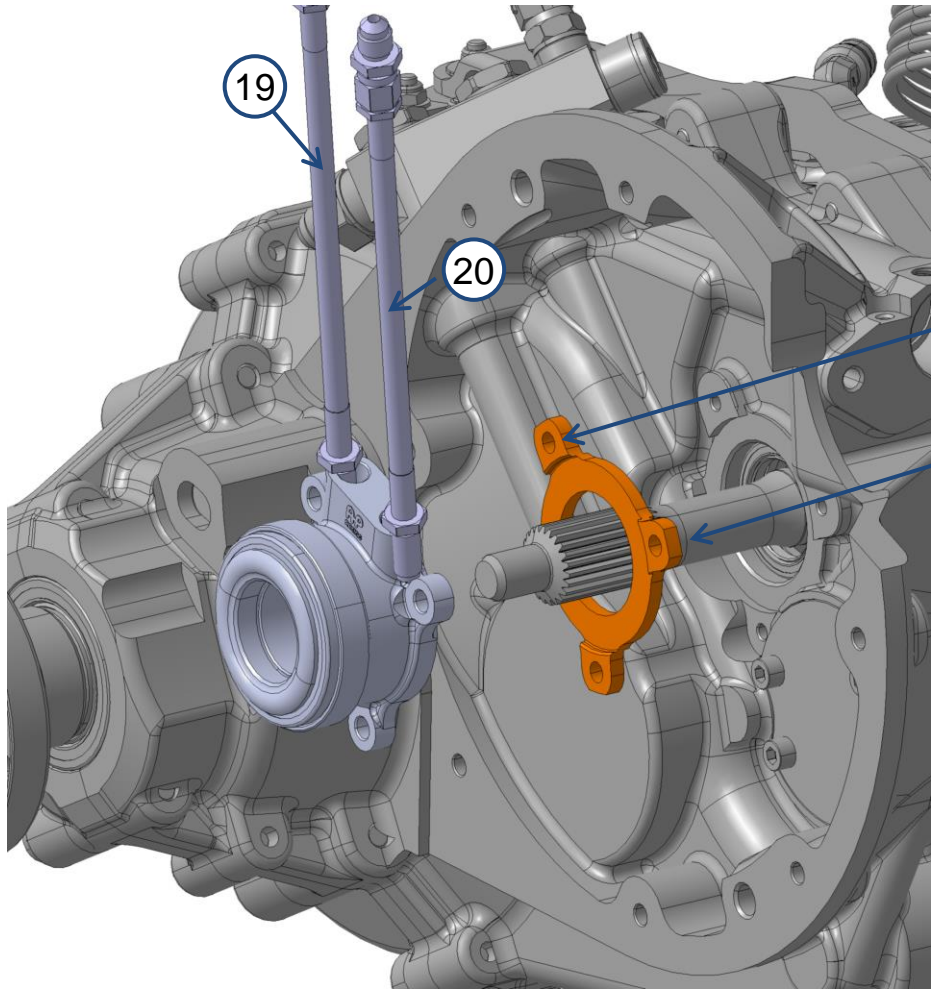

3 x M6 Bolts with Schorr washer  
**10 N.m + Loctite 577**

**Spacer**

For clutch set up mounting:  
**CLUTCH BEARING SPACER** thickness range

Ref Num	Thickness	Comment
4012960	4 MM	Usually used with TILTON Double disc set up with M6x22mm bolt
4012415	5 MM	
4012962	6 MM	
4012596	7 MM	
4012964	8 MM	
4012413	9 MM	
4012965	10 MM	Usually used with TILTON Simple disc set up with M6x30mm bolt
4012966	11 MM	
4012967	12 MM	

No.	Number	Name	Qty.
19	4016498	COP-HOSE CLUTCH SLAVE IN LG: 770MM+ 26MM	1
20	4016499	COP-HOSE CLUTCH SLAVE BLEED LG: 425MM	1

## 5.12.1 POWERTRAIN – Clutch – Hoses

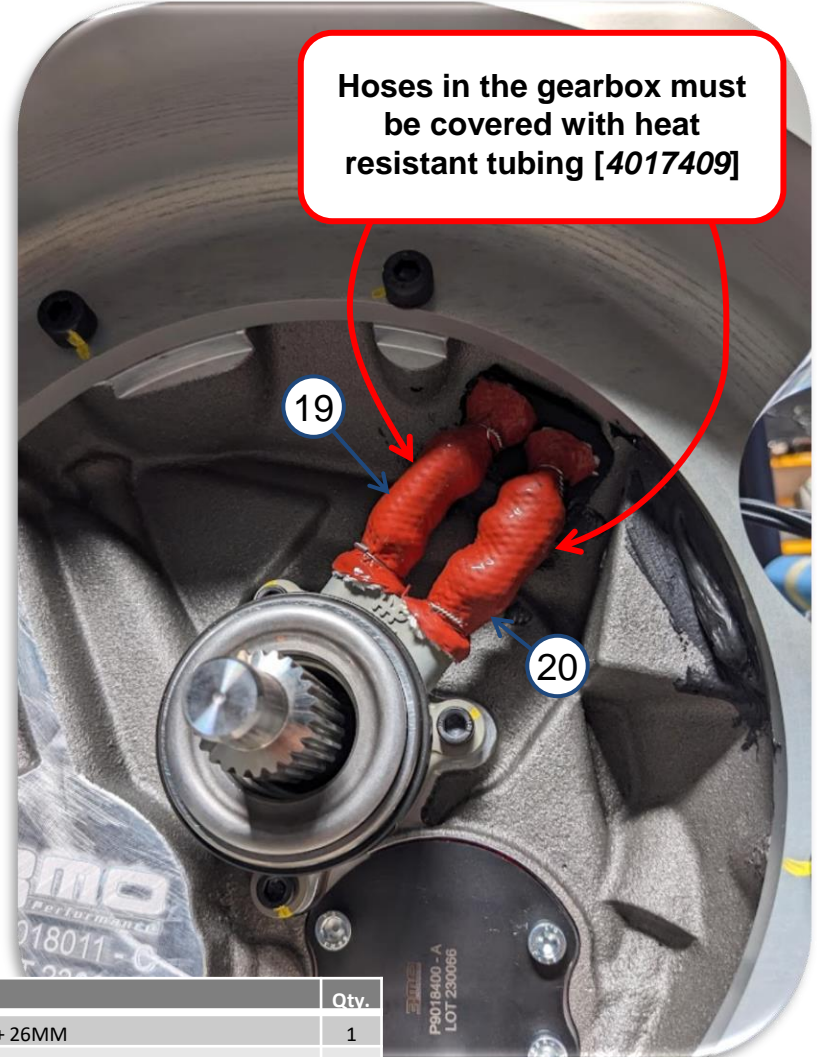
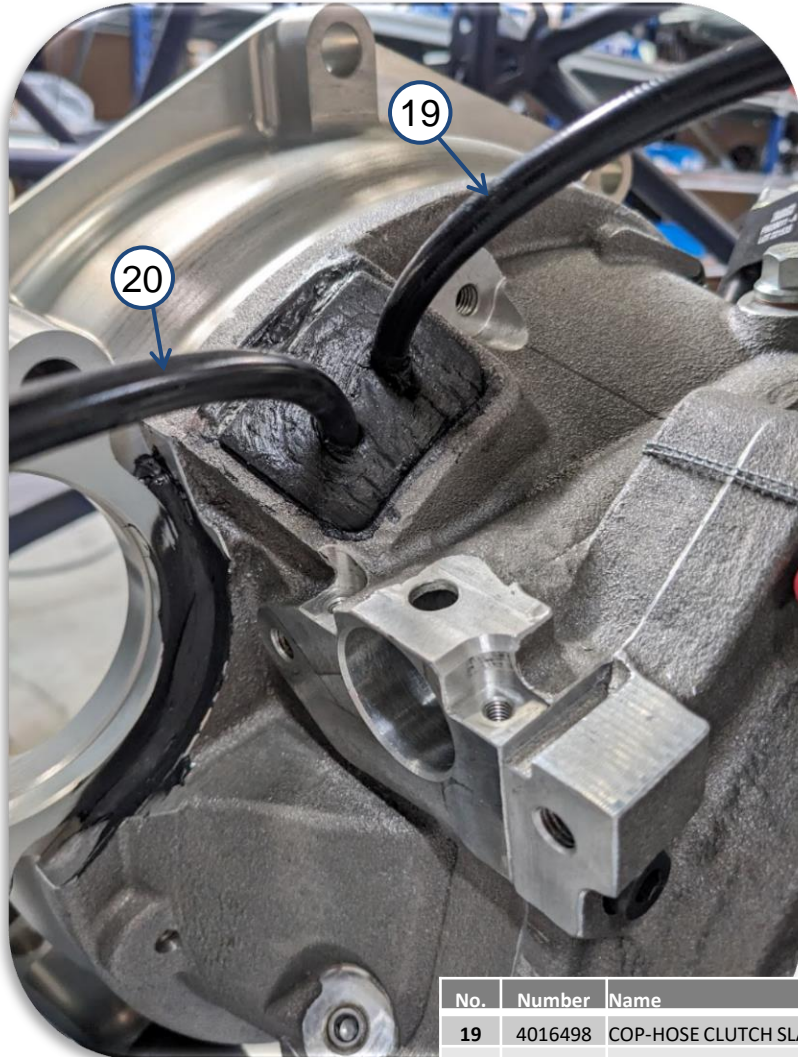

No.	Number	Name	Qty.
19	4016498	COP-HOSE CLUTCH SLAVE IN LG: 770MM+ 26MM	1
20	4016499	COP-HOSE CLUTCH SLAVE BLEED LG: 425MM	1



## 5.12.2 POWERTRAIN – Gearbox – Foam

Clutch hoses window must be deburred

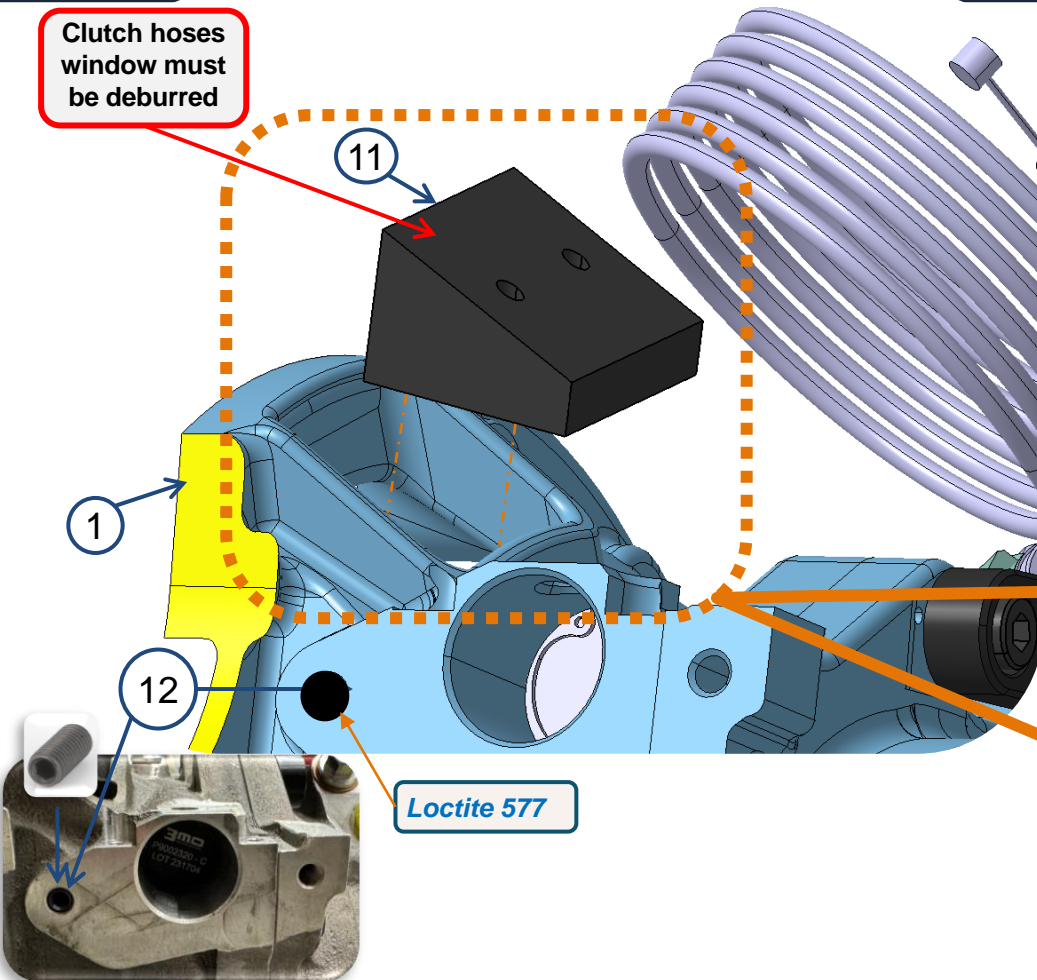

Insert foam into clutch hoses window and cover it with Wurtz RTV as show on pictures



No.	Ref.	Name	Qty.
1	4012295	COP-GEARBOX SEQUENTIAL 5 SPEEDS →	1
-	4012564	DRP-GEARBOX HOUSING – REWORK	1
-	4012294	COP-TO BE DEFINED GEAR BOX TULIP FLANGE	2
11	4018071	DRP-FOAM CLUTCH HOSES WINDOW	1
12	4006235	COP-SCREW	1

## 5.13.1 POWERTRAIN – Clutch Housing – Bushings and Centering pins

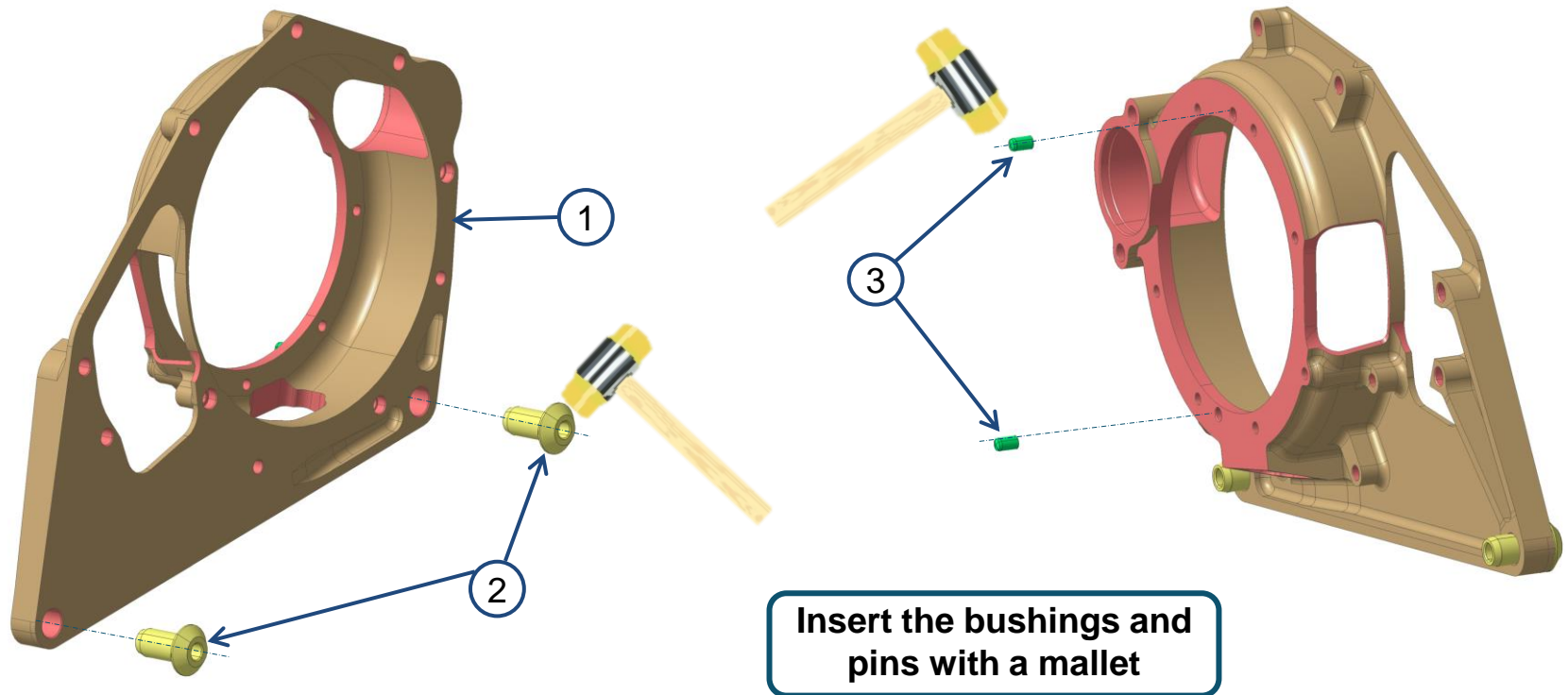

No.	Ref.	Name	Qty.
1	4012363	DRP-CLUTCH HOUSING	1
2	4012386	DRP-BUSHING CLUTCH HOUSING CENTERING	2
3	4012388	SUP-CYLINDRICAL PIN	2

# 5.13.2 POWERTRAIN – Clutch Housing – Fixing to Gearbox

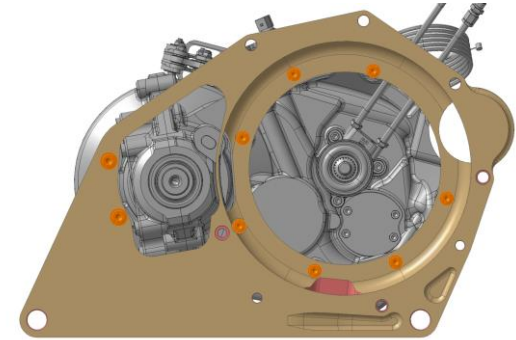
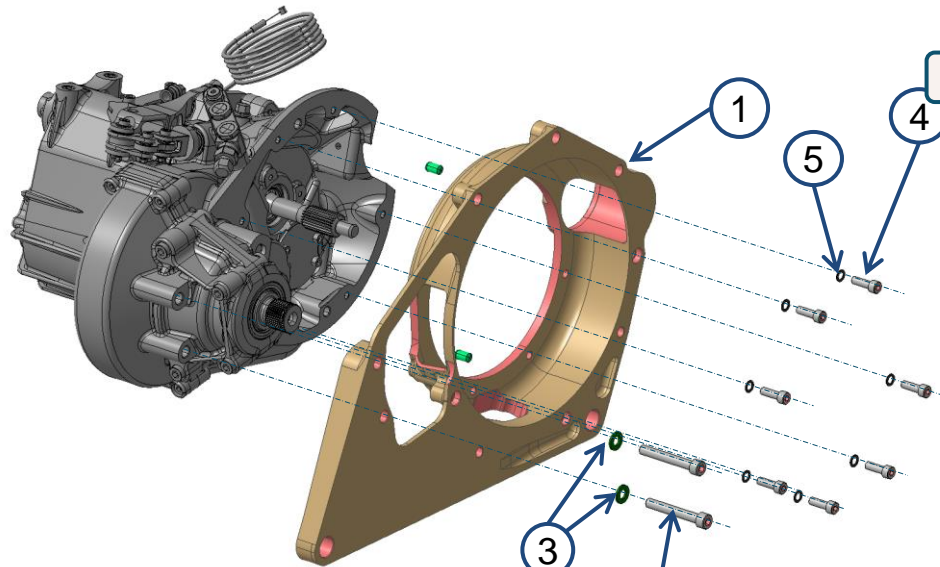

Using Loctite 518 make a seal between the clutch and gearbox

⌧ 50 N.m + Loctite 243

Sealing Zone 1

Sealing Zone 2

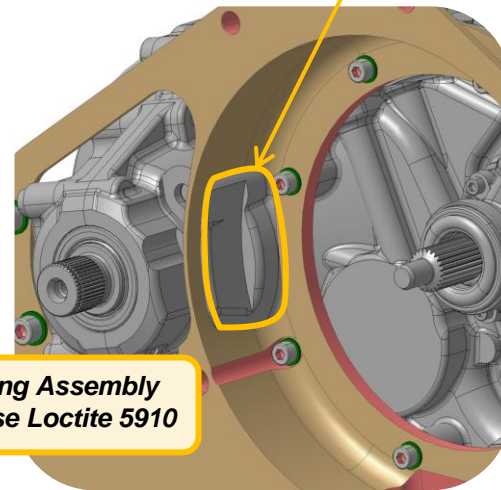
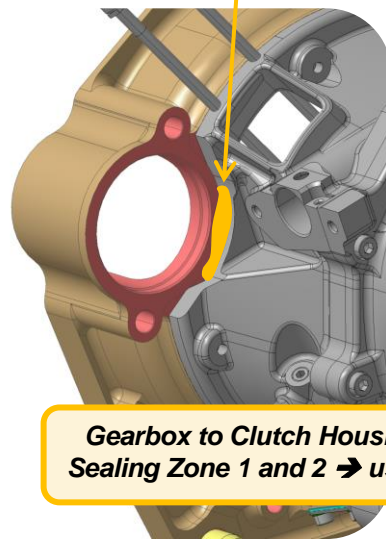

**Gearbox to Clutch Housing Assembly**  
Sealing Zone 1 and 2 → use Loctite 5910

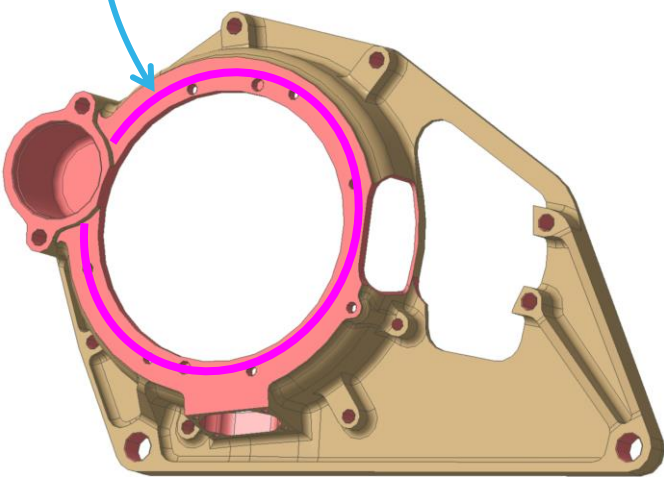

No.	Ref.	Name	Qty.
1	4012363	DRP-CLUTCH HOUSING	1
2	4000651	SUP-HEXAGONAL SOCKET CAP SCREW	2
3	4009152	SUP-PLAIN WASHER	2
4	4000617	SUP-HEXAGONAL SOCKET CAP SCREW	7
5	4013575	COP - WASHER Ø8	7

## 5.13.3 POWERTRAIN – Clutch Housing – Fixing to Chassis

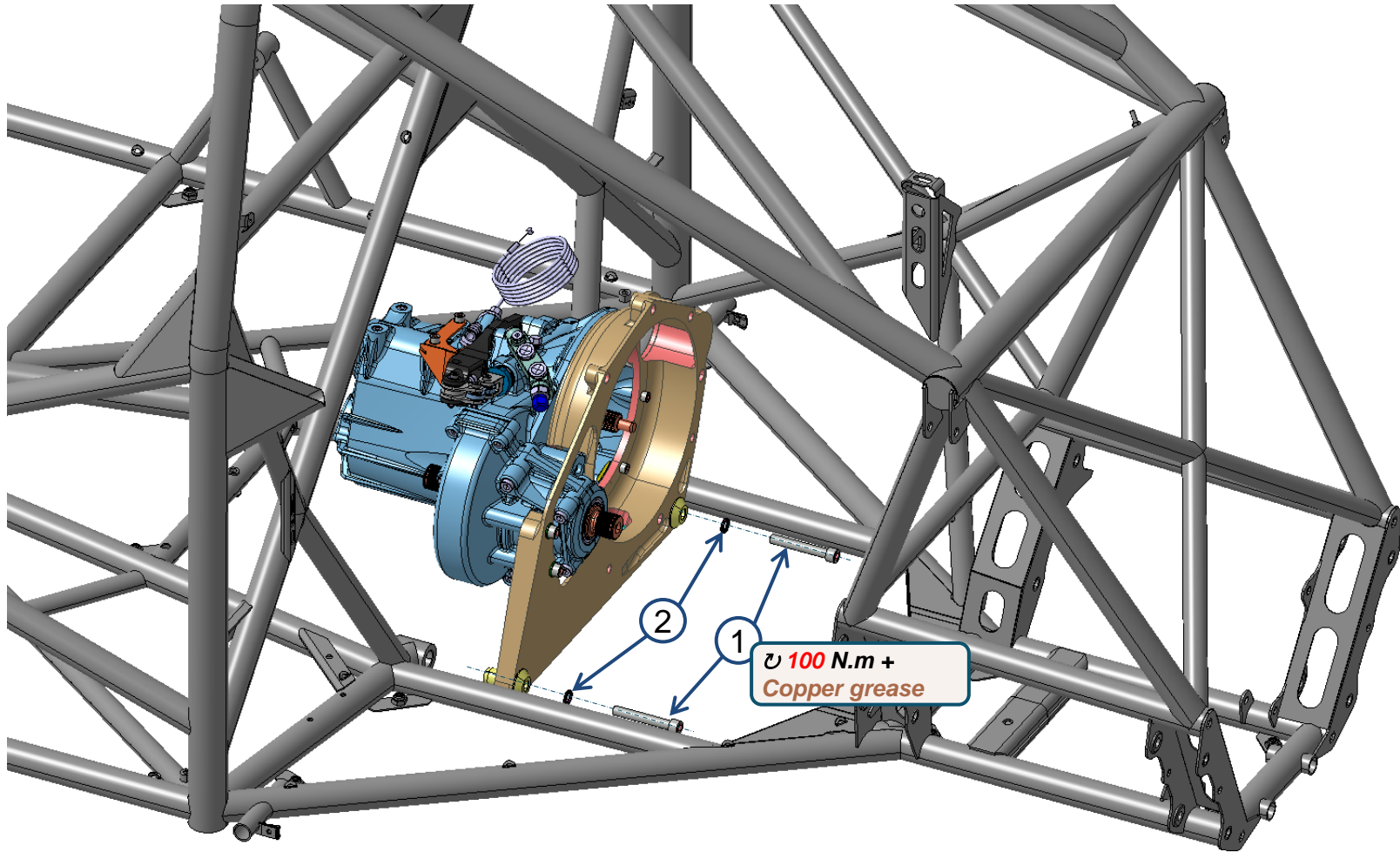

No.	Ref.	Name	Qty.
1	4000684	SUP-HEXAGONAL SOCKET CAP SCREW	2
2	4013574	COP-WASHER NORDLOCK Ø12	2

## 5.13.4 POWERTRAIN – Clutch Housing – Fixing to Motor

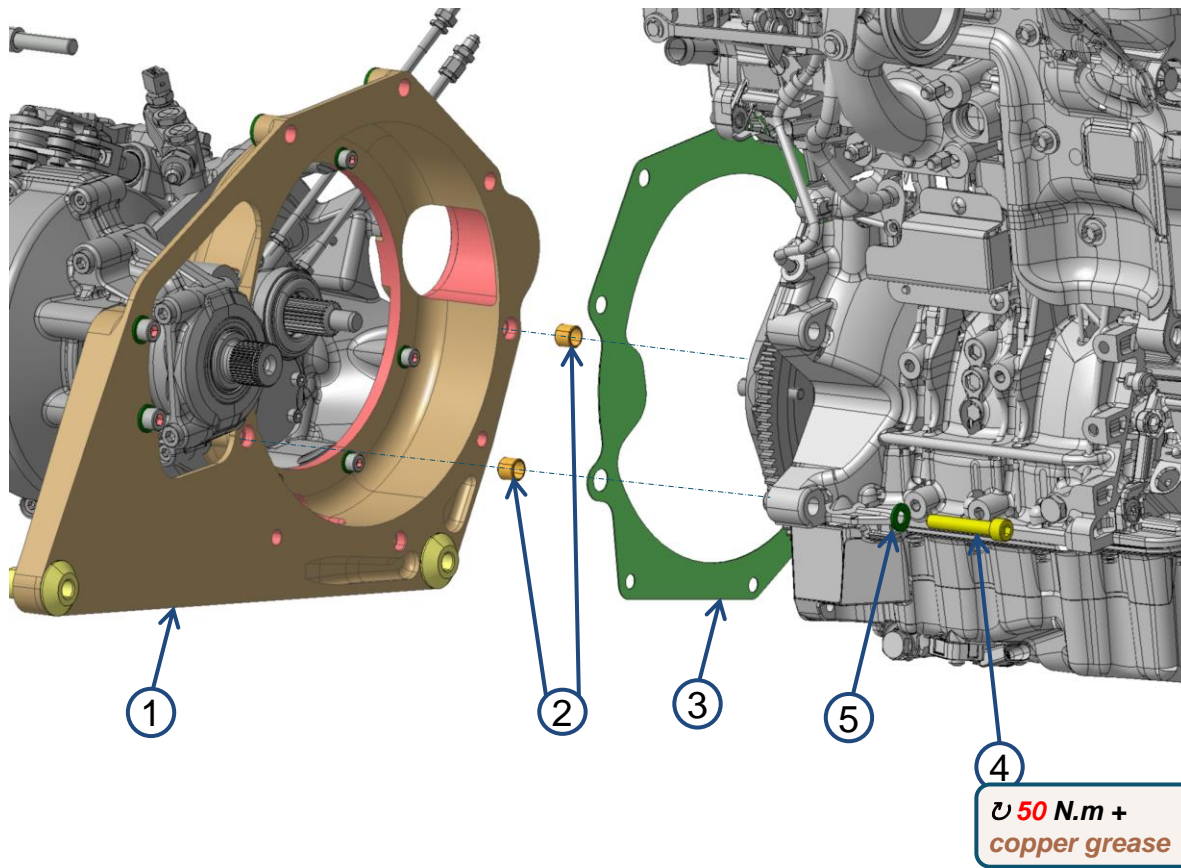

**Step 1:**  
Apply sealing bead on marked area with  
Loctite 5910

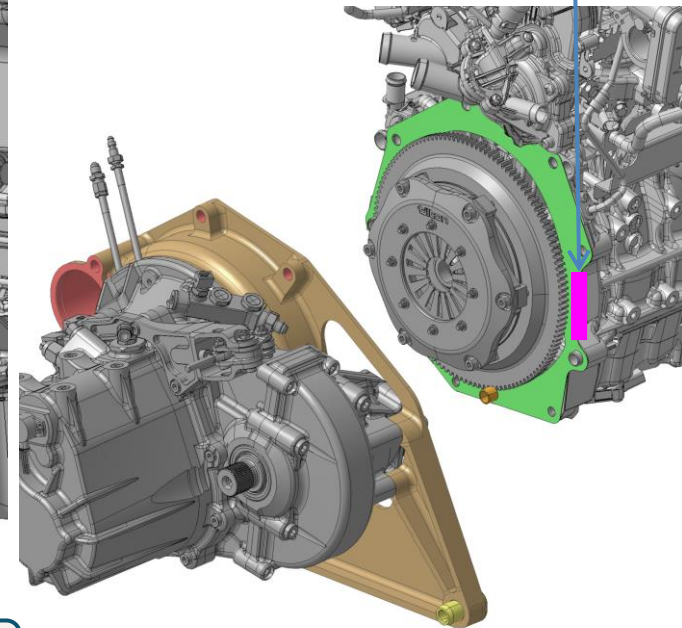

**Engine Assembly on clutch housing**

No.	Ref.	Name	Qty.
1	4012363	DRP-CLUTCH HOUSING	1
2	4012387	DRP-CENTERING BUSH ENGINE SIDE	2
3	4014684	DRP-SHEET CLUTCH FLAT GASKET	1
4	4001028	SUP-HEXAGONAL SOCKET CAP SCREW	1
5	4009153	SUP-PLAIN WASHER	1

## 5.13.5 POWERTRAIN – Clutch Housing – Fixing to Motor

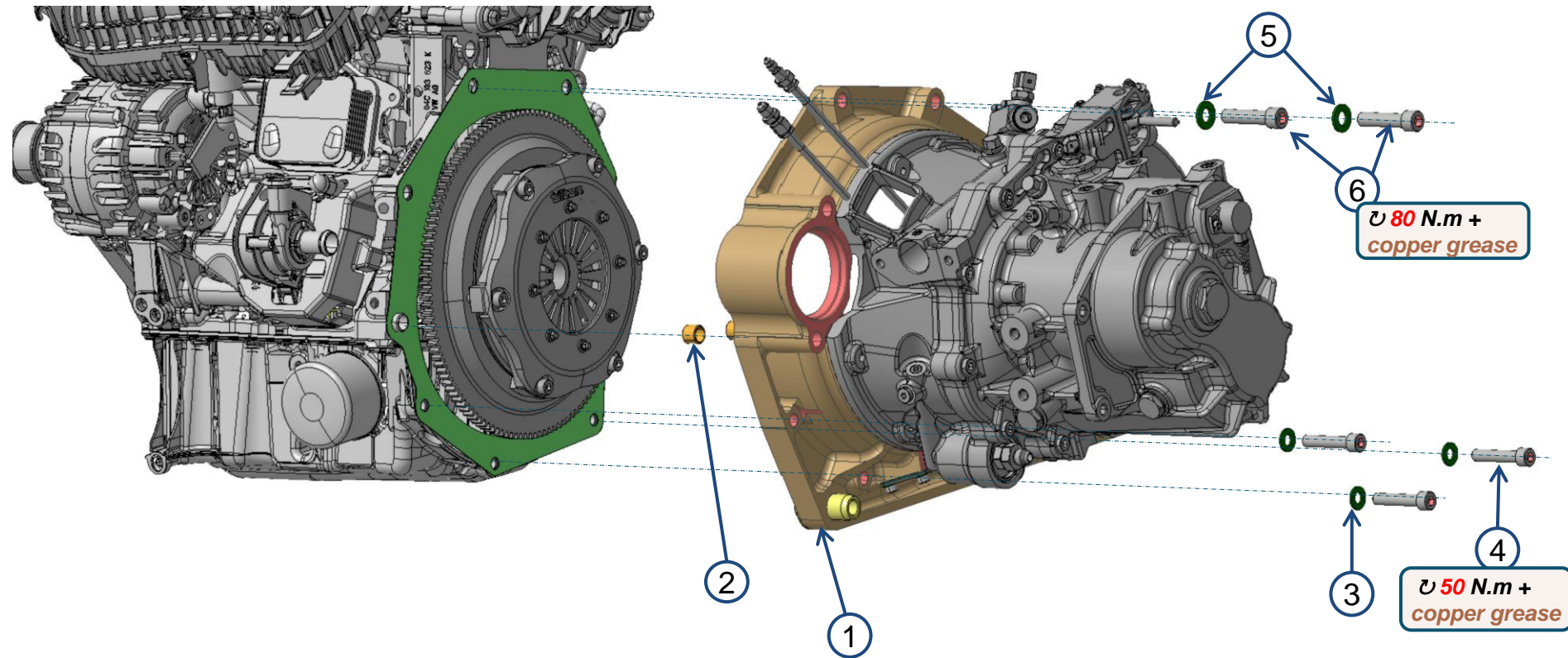

### Engine Assembly on clutch housing

No.	Ref.	Name	Qty.
1	4012363	DRP-CLUTCH HOUSING	1
2	4012387	DRP-CENTERING BUSH ENGINE SIDE	2
3	4009152	SUP-PLAIN WASHER	3
4	4000647	SUP-HEXAGONAL SOCKET CAP SCREW	3
5	4009153	SUP-PLAIN WASHER	2
6	4000678	SUP-HEXAGONAL SOCKET CAP SCREW	2

# 5.14 POWERTRAIN – Engine support cross member

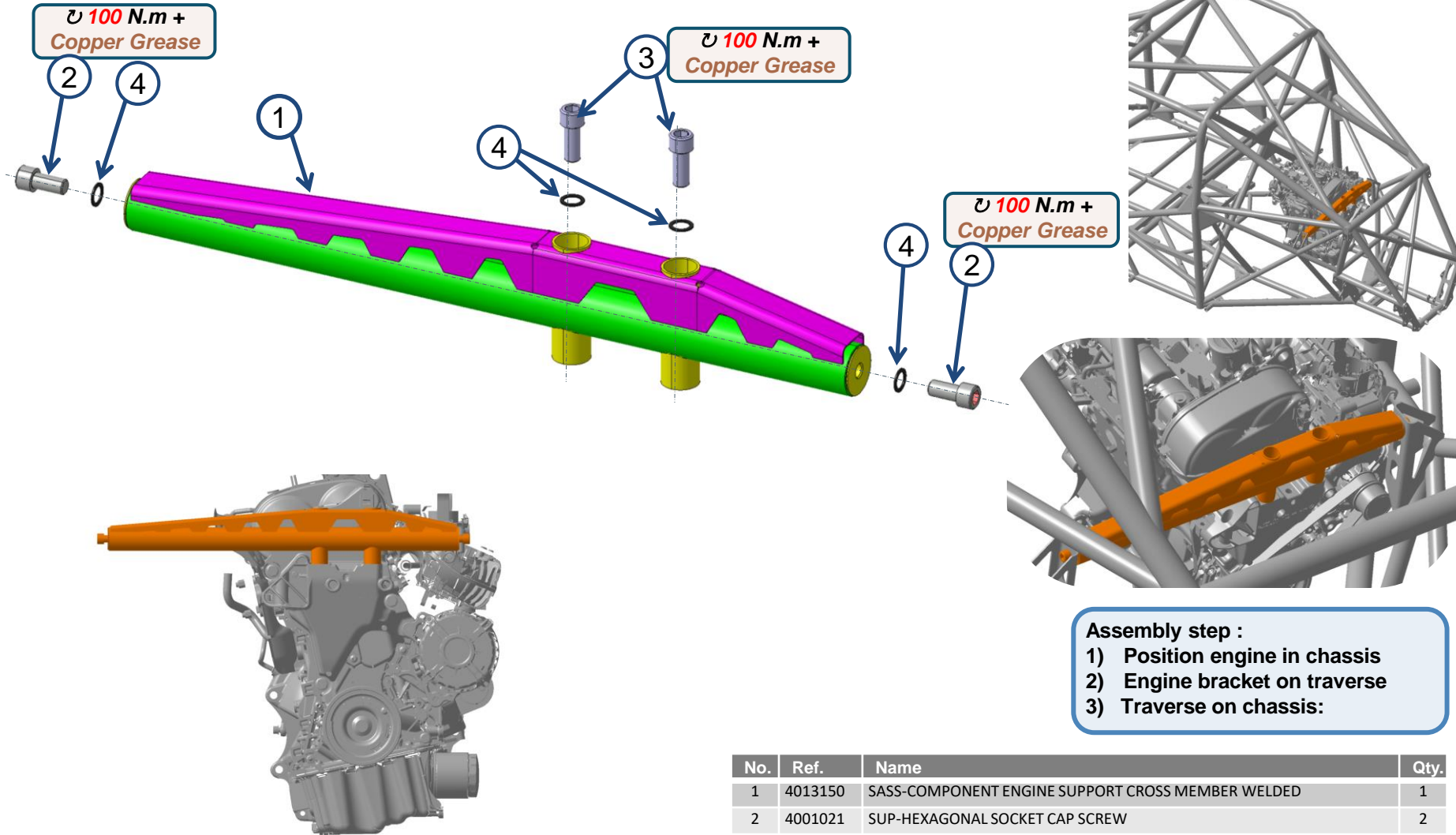

**Assembly step :**  
 1) Position engine in chassis  
 2) Engine bracket on traverse  
 3) Traverse on chassis:

No.	Ref.	Name	Qty.
1	4013150	SASS-COMPONENT ENGINE SUPPORT CROSS MEMBER WELDED	1
2	4001021	SUP-HEXAGONAL SOCKET CAP SCREW	2
3	010437	SUP-VIS CHC M12	2
4	4014971	COP-WASHER Ø12 SCHNORR	4

## 5.15 POWERTRAIN – Gearbox Axis Check

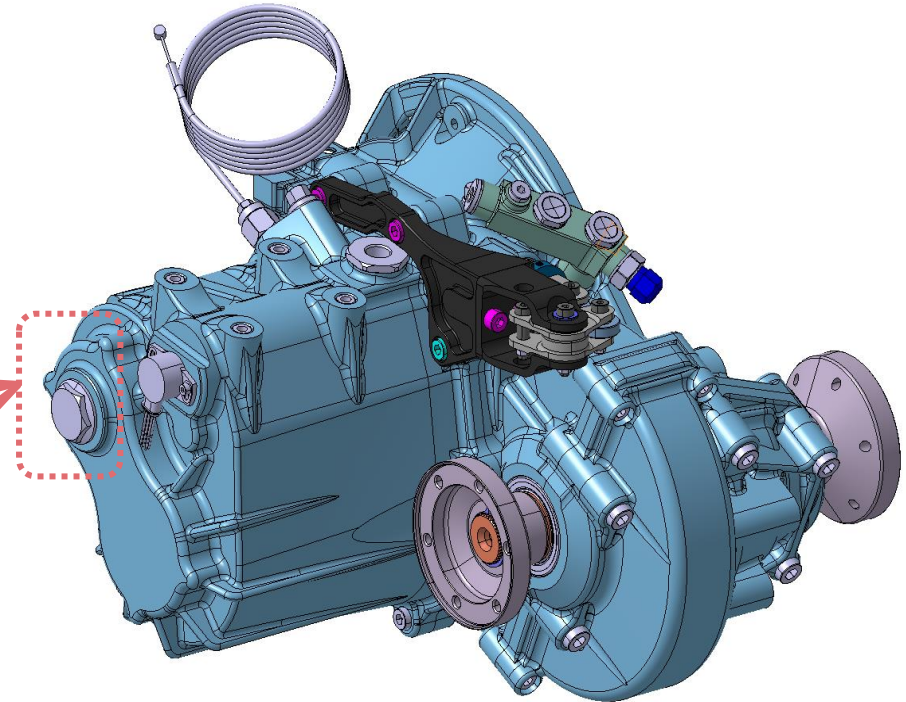

Once the gearbox has been assembled with the motor, you must check that the splines are as shown on the picture. There must be no vertical space between the internal and external splines.

Once you have checked, please re-screw the plug onto the gearbox → **4 N.m**



## 5.16 POWERTRAIN – Clutch Housing – Inspection Hatch

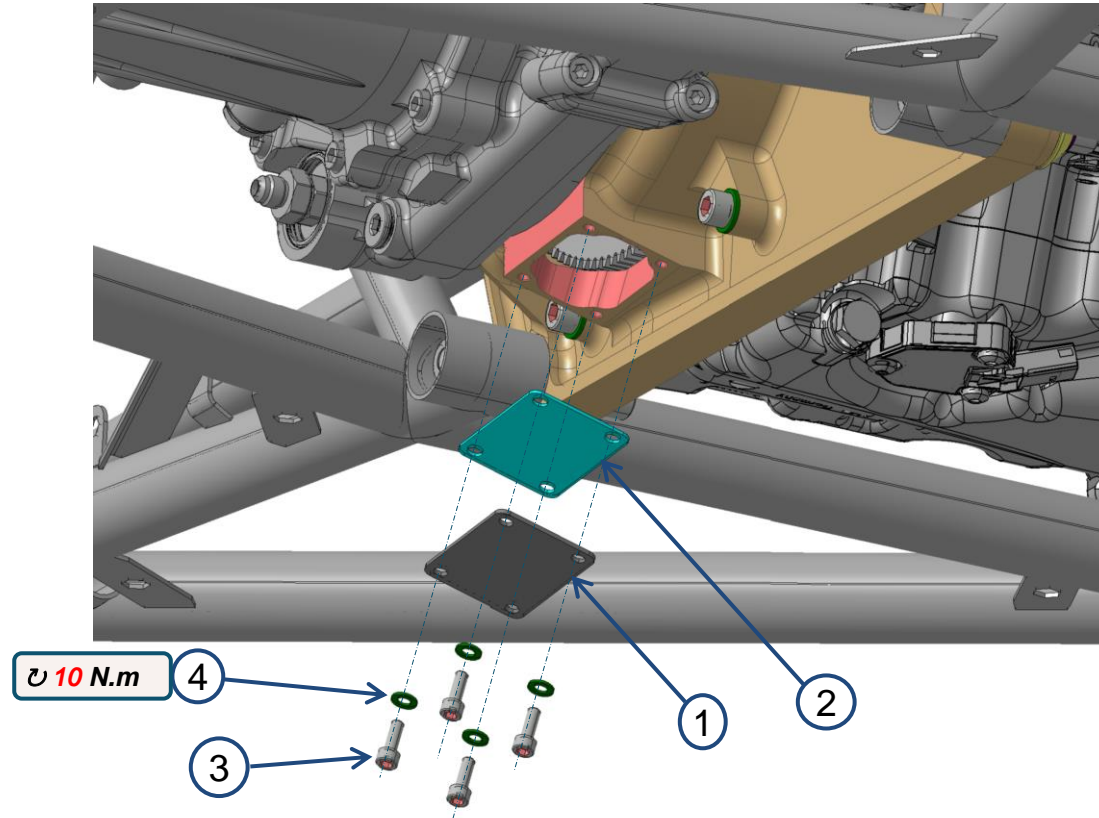

### INSPECTION HATCH ASSEMBLY

No.	Ref.	Name	Qty.
1	4012378	DRP-INSPECTION HATCH - CLUTCH HOUSING	1
2	4012379	DRP-SEALING FLAT GASKET	1
3	4000586	SUP-HEXAGONAL SOCKET CAP SCREW	4
4	4009150	SUP-PLAIN WASHER	4

## 5.17 POWERTRAIN – GearBox cooler

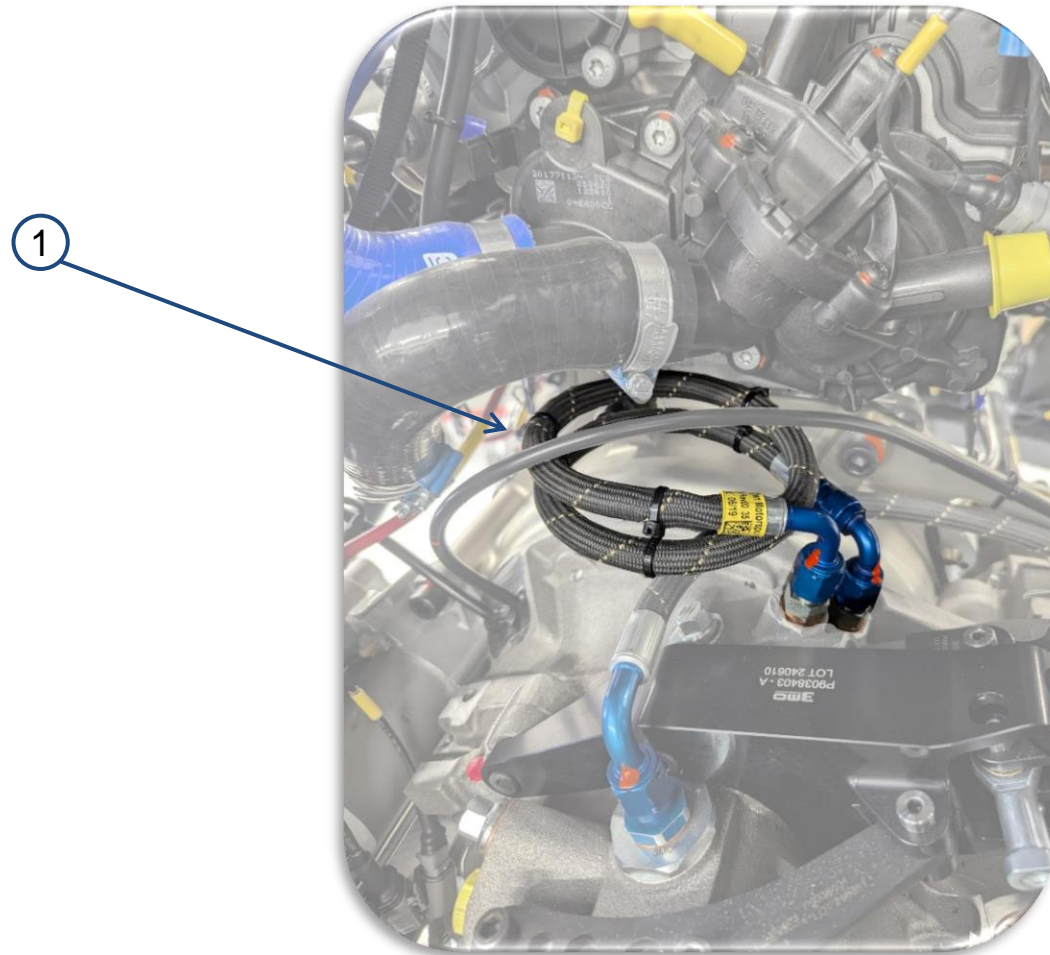

No.	Ref.	Name	Qty.
1	4021904	DRP-INSPECTION HATCH - CLUTCH HOUSING	1

# 5.18 POWERTRAIN – Engine Starter

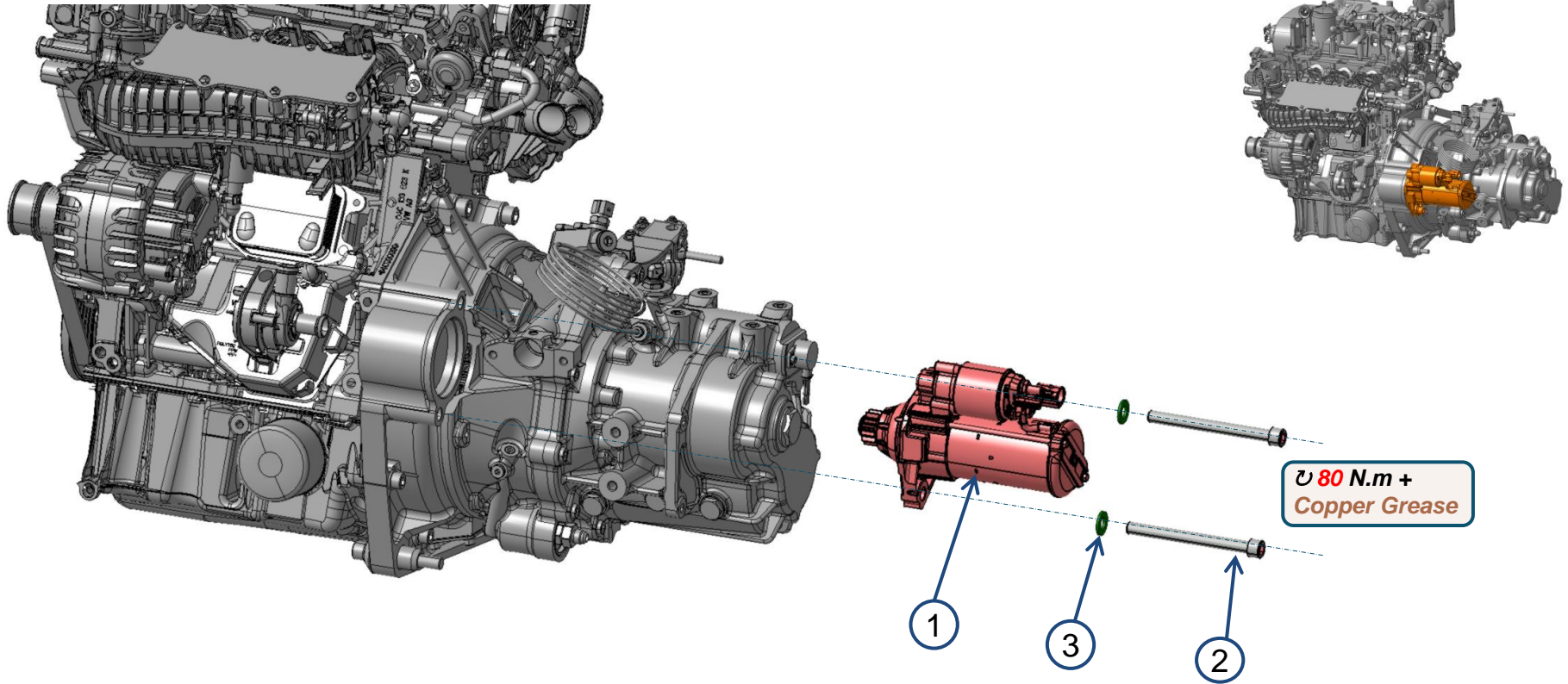

No.	Ref.	Name	Qty.
1	4020442	WIRED STARTER	1
2	4001368	SUP-HEXAGONAL SOCKET CAP SCREW	2
3	4009153	SUP-PLAIN WASHER	2

# 5.19.1 POWERTRAIN – Decanter – Tubing

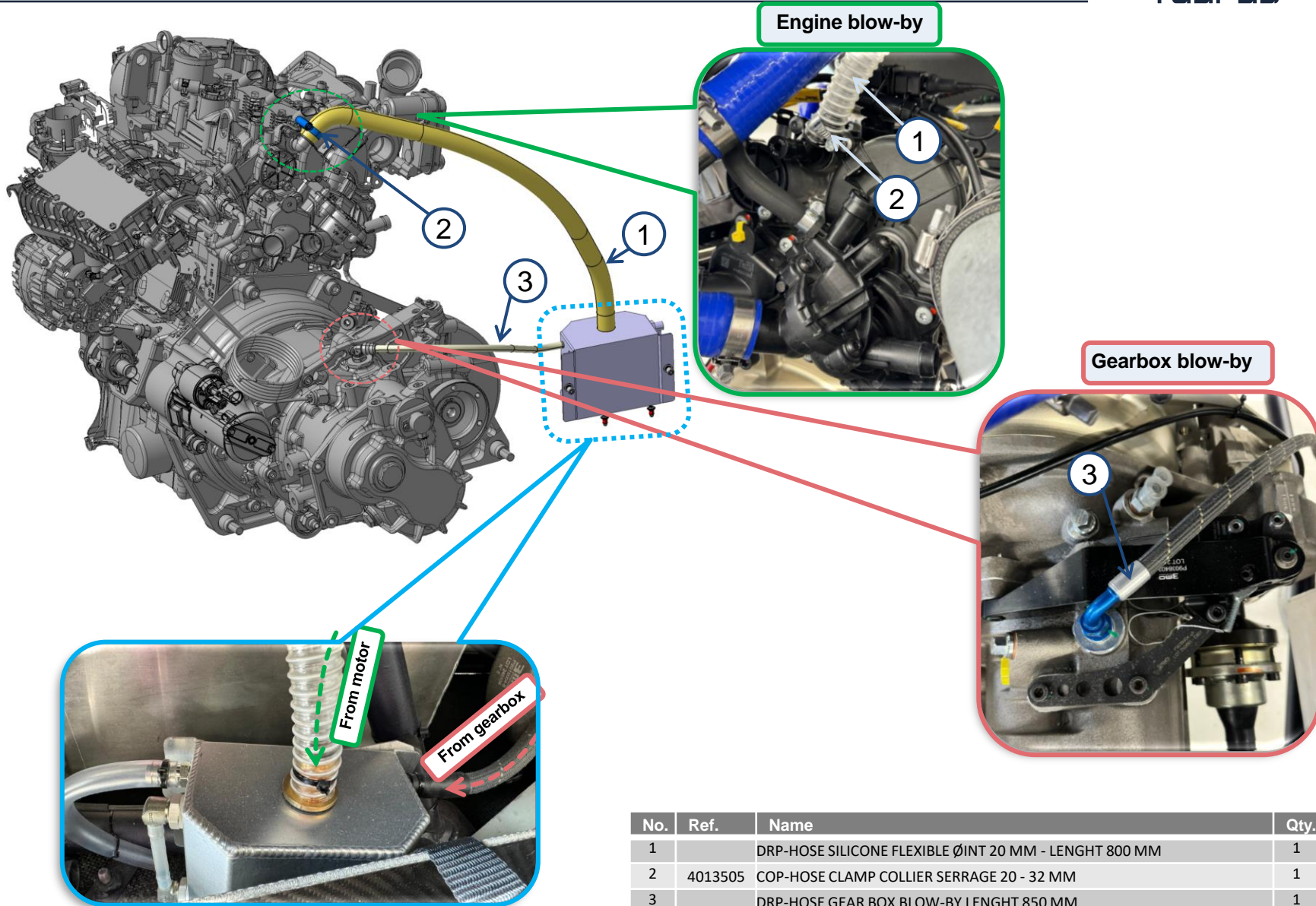

No.	Ref.	Name	Qty.
1		DRP-HOSE SILICONE FLEXIBLE ØINT 20 MM - LENGHT 800 MM	1
2	4013505	COP-HOSE CLAMP COLLIER SERRAGE 20 - 32 MM	1
3		DRP-HOSE GEAR BOX BLOW-BY LENGHT 850 MM	1

## 5.19.2 POWERTRAIN – Decanter – Preparation

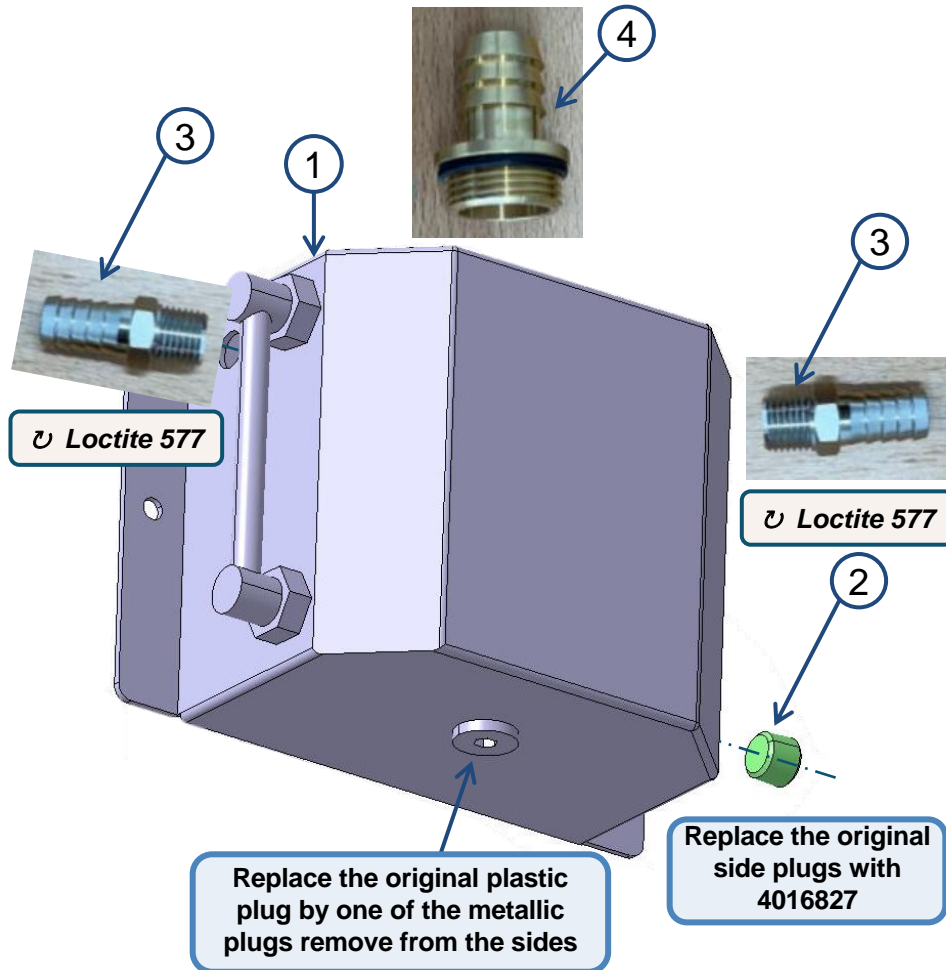

**To be updated**

“Gardena kit”:  
Reference to identify



No.²	Ref.	Name	Qty.
1	4013721	COP- BLOW BYE TANK 1LITER	1
2	4016827	COP-PLUG G 1/4 STEEL LEGRIS 02061300	1
3			2
4			1

## 5.19.3 POWERTRAIN– Fixing to Chassis

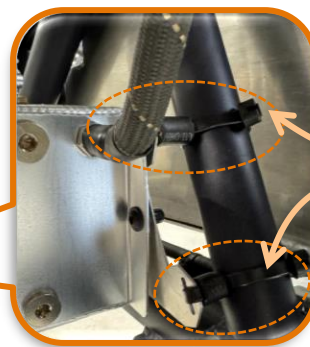
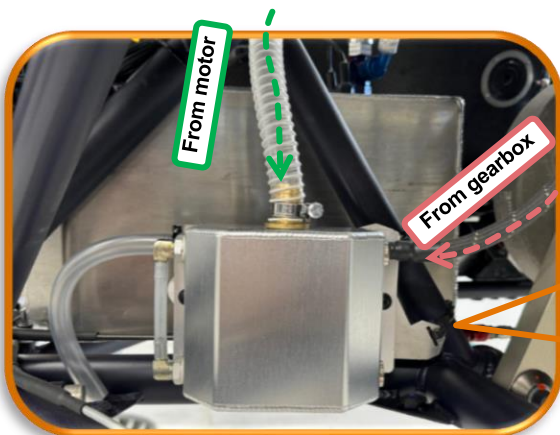
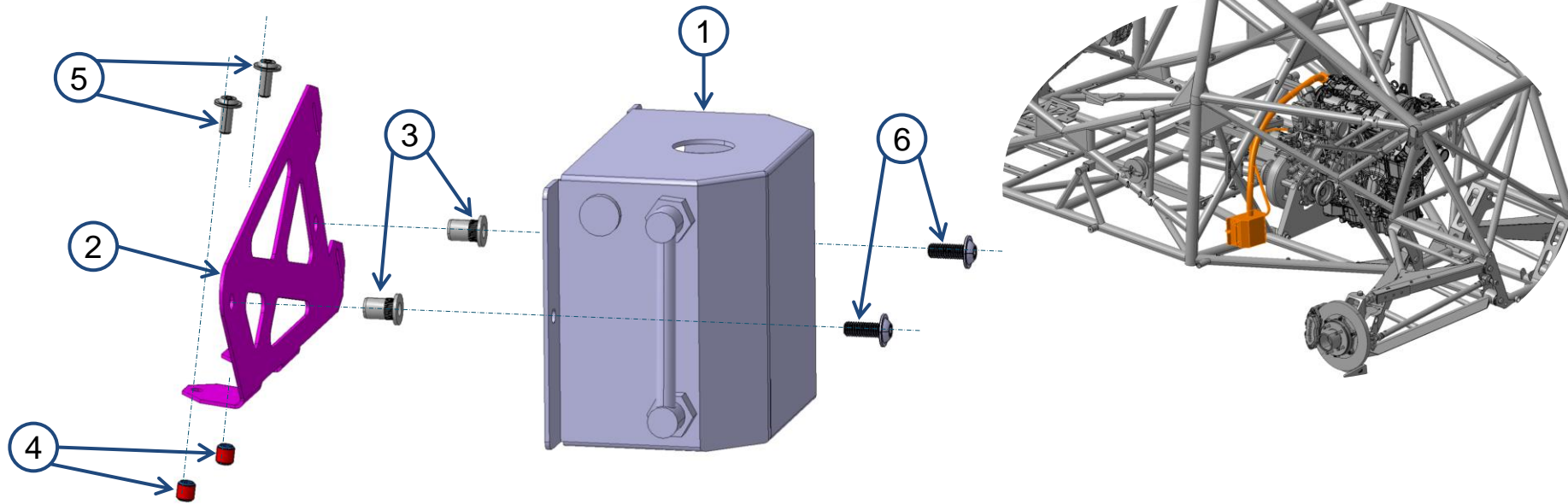

Use plastic collars to secure the tank to the chassis

No.	Ref.	Name	Qty.
1	4013721	COP- BLOW BYE TANK 1LITER	1
2	4013757	DRP TOLE SUPPORT DE BLOW BY	1
3	4014808	COP-INSERT TAPPED M6 - ROUND SHAPE	2
4	4015179	COP-HELICAL THREAD INSERT M5	2
5	4013851	COP-SCREW VIS A EMBASE TETE BASSE	2
6	4013372	COP-SCREW TBHC	2

## 5.20.1 POWERTRAIN – Exhaust line – 2023

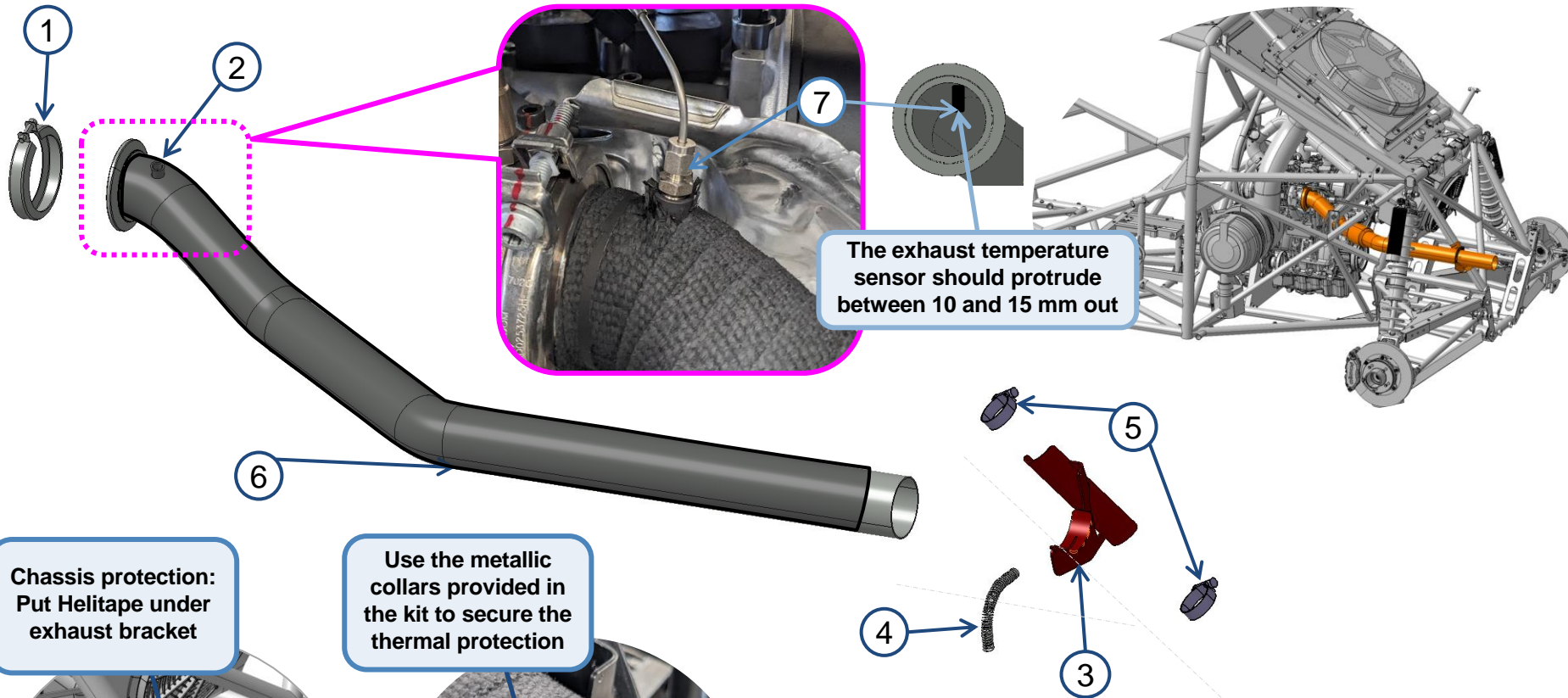

**Chassis protection:**  
Put Helitape under exhaust bracket

Use the metallic collars provided in the kit to secure the thermal protection

No.	Ref.	Name	Qty.
1	4013861	COP-HOSE CLAMP TURBOCHARGER – EXHAUST	1
2	4013737	SASS-EXHAUST PIPE – WELDED	1
3	4013875	SASS-BRACKET EXHAUST – WELDED	1
4	4013855	COP-SPRING EXHAUST - LENGTH 80-120MM	1
5	4013878	COP-HOSE CLAMP	2
6	4014642	COP-EXHAUST LINE THERMAL PROTECTION KIT - DEI	1
7	4016592	SASS-WIRING EXHAUST T°C SENSOR AFTER TURBOCHARGER	1

## 5.20.2 POWERTRAIN – Exhaust line – 2024

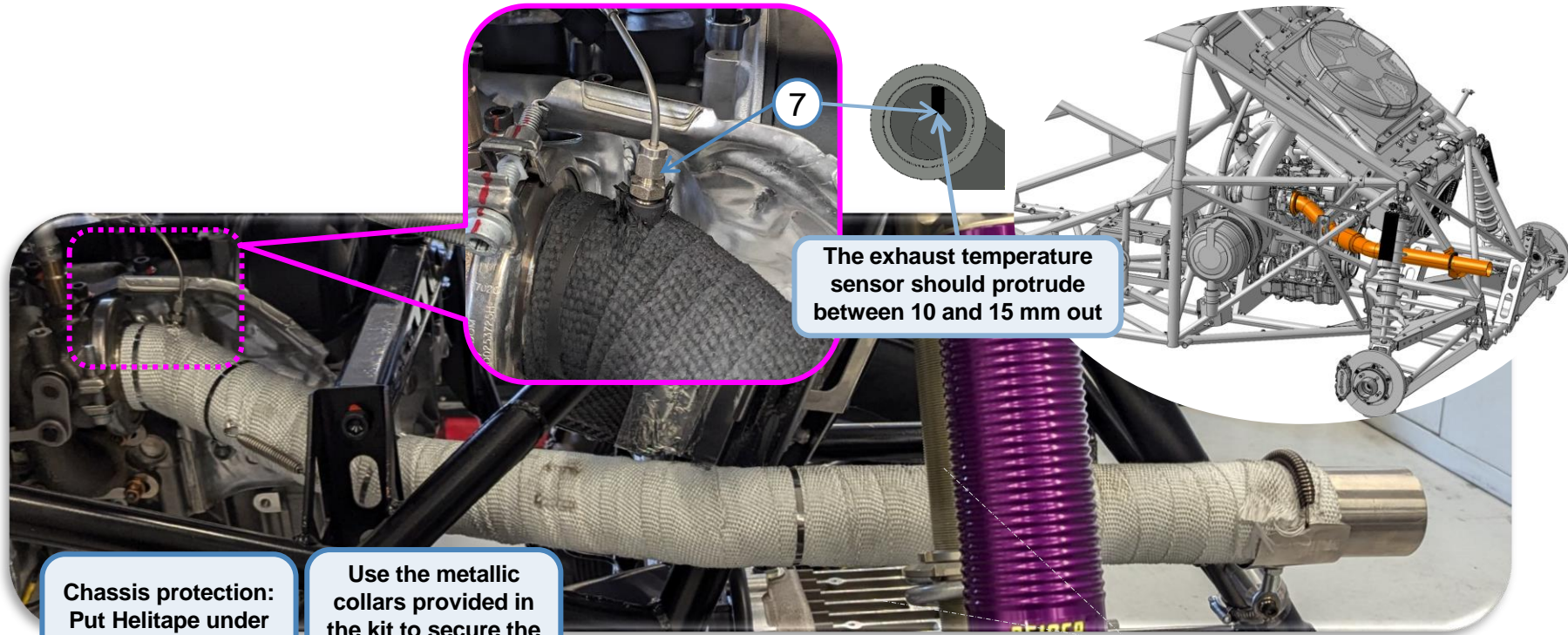

No.	Ref.	Name	Qty.
1	4013861	COP-HOSE CLAMP TURBOCHARGER – EXHAUST	1
2	4013737	SASS-EXHAUST PIPE – WELDED	1
3	4013875	SASS-BRACKET EXHAUST – WELDED	1
4	4013855	COP-SPRING EXHAUST - LENGTH 80-120MM	1
5	4013878	COP-HOSE CLAMP	2
6	4014642	COP-EXHAUST LINE THERMAL PROTECTION KIT – DEI	1
7	4016592	SASS-WIRING EXHAUST T°C SENSOR AFTER TURBOCHARGER	1



## 5.21 POWERTRAIN – Engine – Tools / Spare Parts

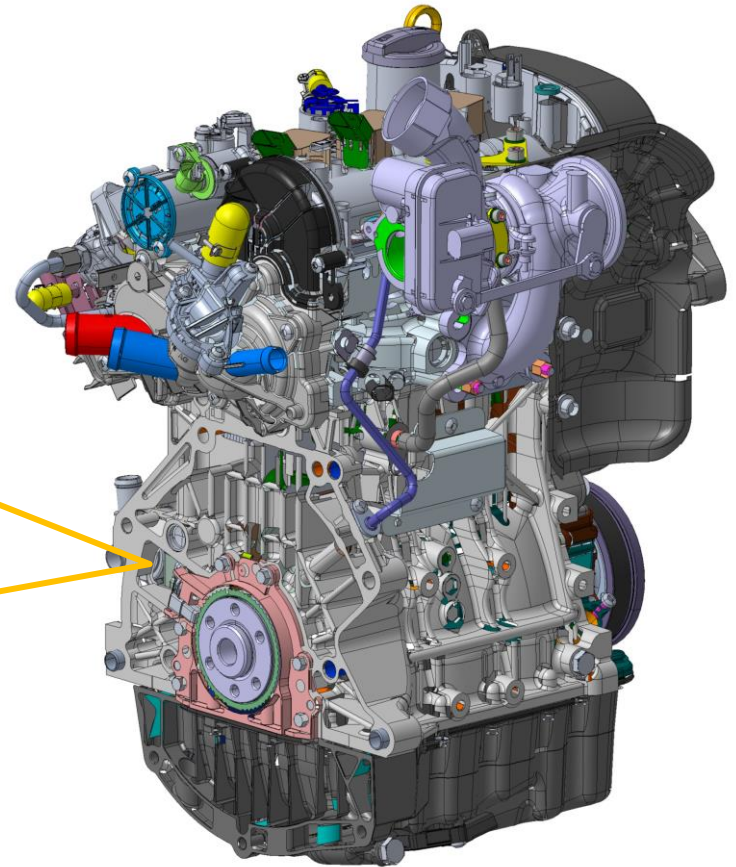
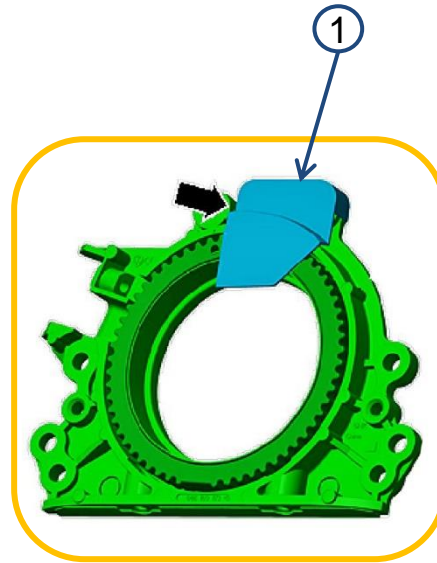
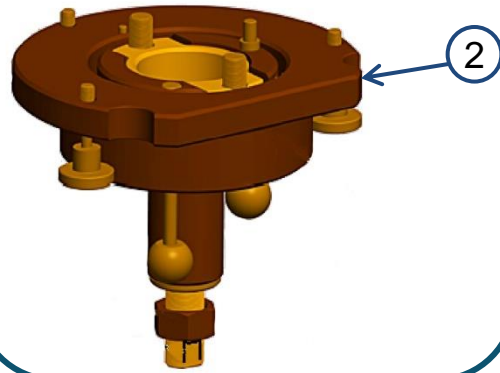

No.	Ref.	Number-Version-Name	Qty.
1	4016385	COP-SEALING FLANGE CRANKSHAFT	1
2	4016386	COP-SEALING FLANGE CRANKSHAFT MOUNTING TOOL	1

## Section 6

### Cooling system

# 6.1 COOLING – Air Vein Composite – Rear overview

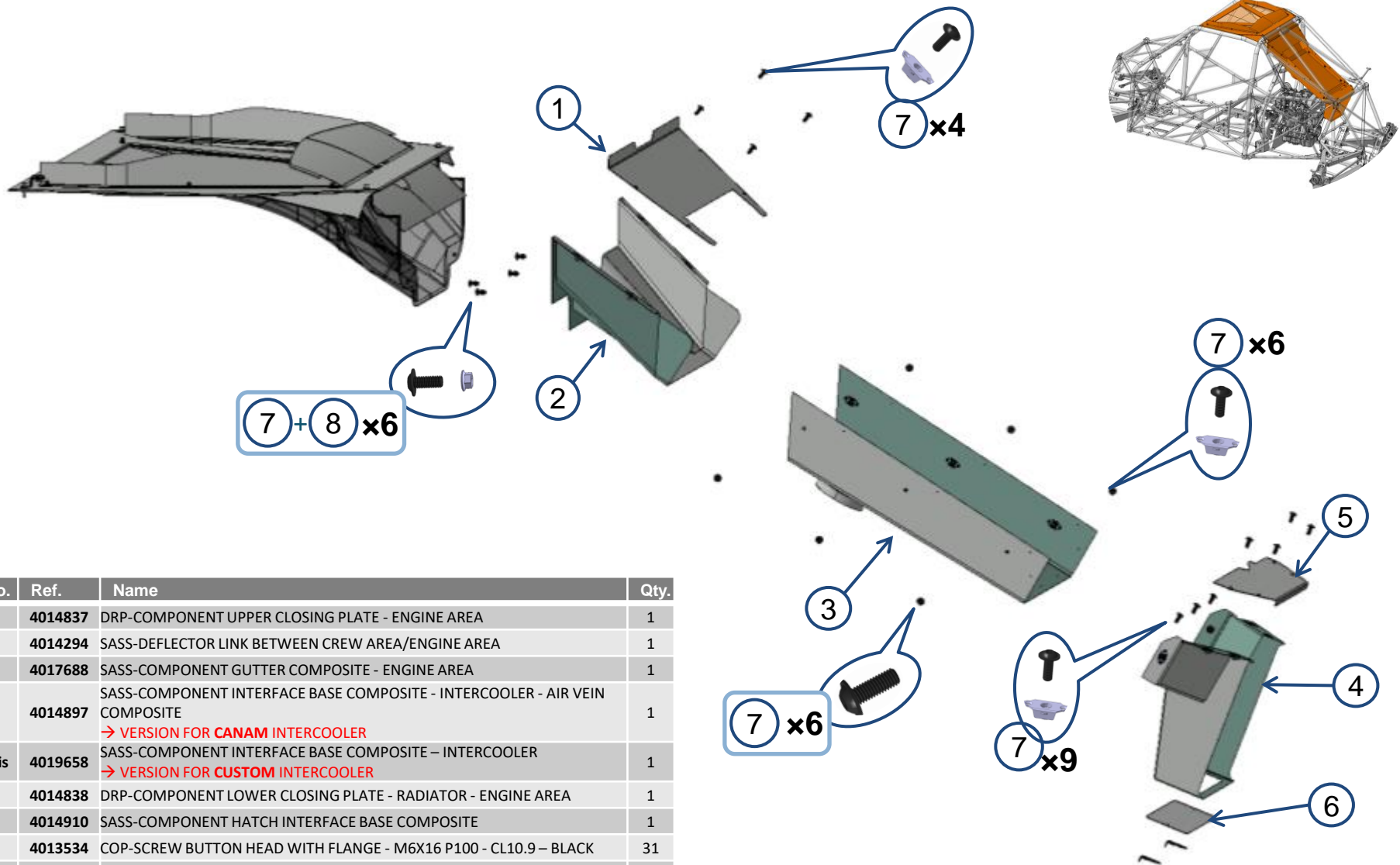

No.	Ref.	Name	Qty.
1	4014837	DRP-COMPONENT UPPER CLOSING PLATE - ENGINE AREA	1
2	4014294	SASS-DEFLECTOR LINK BETWEEN CREW AREA/ENGINE AREA	1
3	4017688	SASS-COMPONENT GUTTER COMPOSITE - ENGINE AREA	1
4	4014897	SASS-COMPONENT INTERFACE BASE COMPOSITE - INTERCOOLER - AIR VEIN COMPOSITE → VERSION FOR <b>CANAM</b> INTERCOOLER	1
4bis	4019658	SASS-COMPONENT INTERFACE BASE COMPOSITE – INTERCOOLER → VERSION FOR <b>CUSTOM</b> INTERCOOLER	1
5	4014838	DRP-COMPONENT LOWER CLOSING PLATE - RADIATOR - ENGINE AREA	1
6	4014910	SASS-COMPONENT HATCH INTERFACE BASE COMPOSITE	1
7	4013534	COP-SCREW BUTTON HEAD WITH FLANGE - M6X16 P100 - CL10.9 – BLACK	31
8	4013685	SUP-LOCKNUT WITH FLANGE - M6X1.00 - SIMMONDS	6

## 6.2.1 COOLING – Air Vein Composite – Rear details

**CAUTION : Make sure that the air flow hits no walls / steps.**

It is imperative for the transitions between air vein components to be as smooth as possible, as steps can drastically reduce the air flow. Adjust the height of the components accordingly.

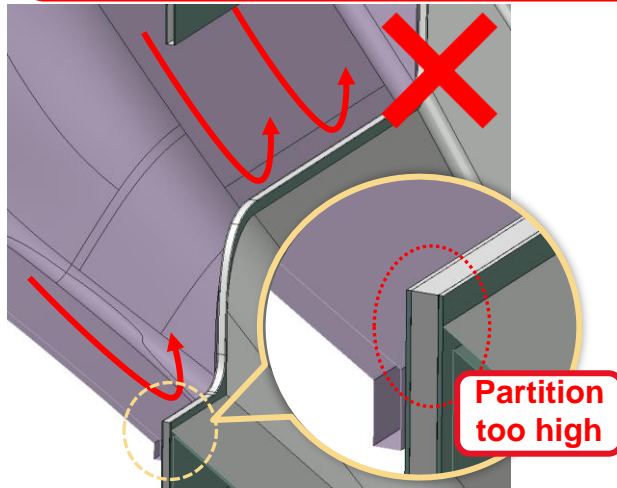

If the partition is too high and makes a step, rework the partition with a Dremel as show on picture bellow

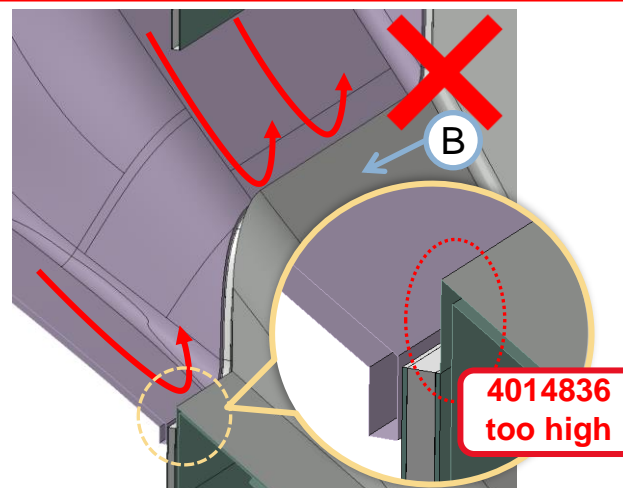

If 4014836 (B) is too high, adjust the position so that it is lower than the partition

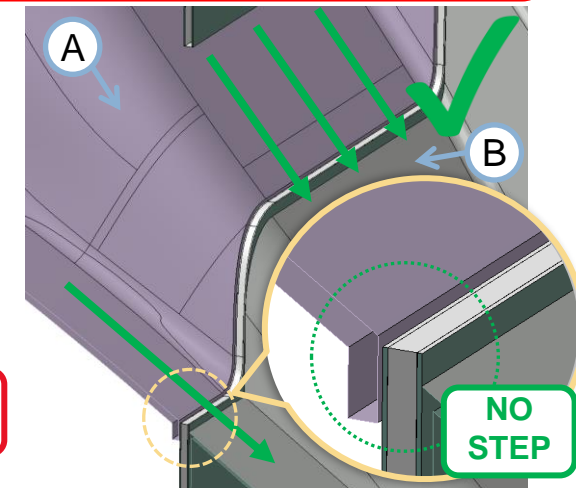

The partition must be slightly below 4013854 (A) and 4014836 (B) must be slightly below the partition.



## 6.2.2 COOLING – Air Vein Composite – Rear details

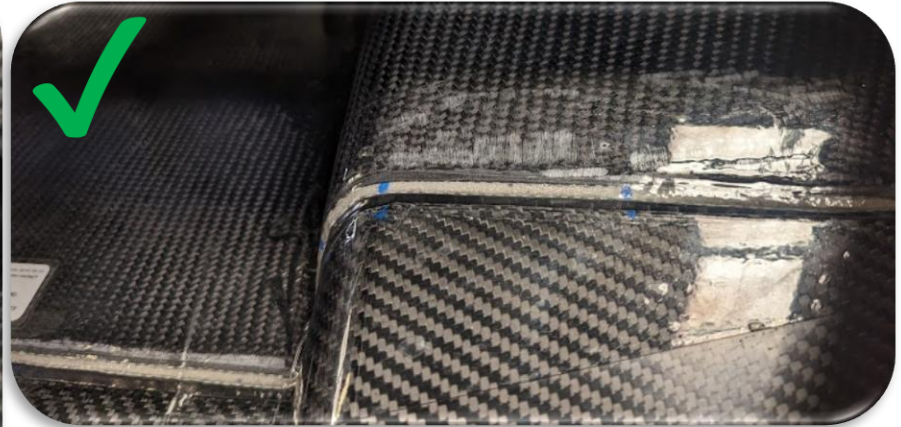
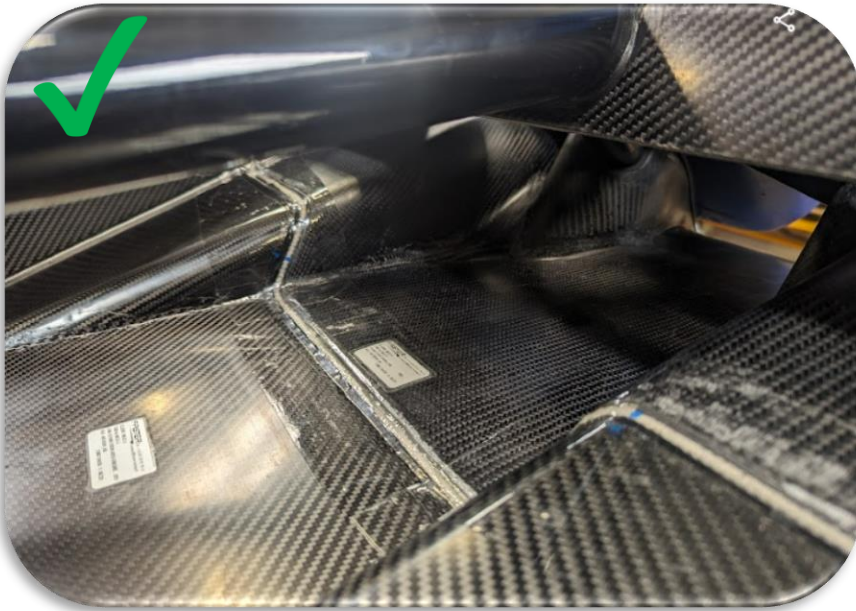

Parts #1 and #2 must be taped together with helitape  
**100mm width** to help improve the air flow.



## 6.2.3 COOLING – Air Vein Composite – Rear details

### DEFLECTOR BETWEEN CREW AREA/ENGINE AREA POSITIONNING

Grind the upper partition panel to improve air flow

x2

Parts #1 and #2 ending on the **bottom** face of the radiator:  
NO step allowed

No height reduction of the gutter allowed

7 + 8 x2

No.	Ref.	Name	Qty.
1	4014837	DRP-COMPONENT UPPER CLOSING PLATE - ENGINE AREA	1
2	4014294	SASS-DEFLECTOR LINK BETWEEN CREW AREA/ENGINE AREA	1
3	4017688	SASS-COMPONENT GUTTER COMPOSITE - ENGINE AREA	1
7	4013534	COP-SCREW BUTTON HEAD WITH FLANGE - M6X16 P100 - CL10.9 – BLACK	2
8	4013685	SUP-LOCKNUT WITH FLANGE - M6X1.00 - SIMMONDS	2

## 6.2.4 COOLING – Air Vein Composite – Bottom details 1/2

**Use tape [REF] to make sure the air vein is sealed.**



**4014837 must be taped to the radiator to ensure a good airflow and seal.**



**Use Aluminium tape to ensure that the air vein is well sealed - #ref**



**Hatch on the intercooler interface**

## 6.2.5 COOLING – Air Vein Composite – Bottom details 2/2

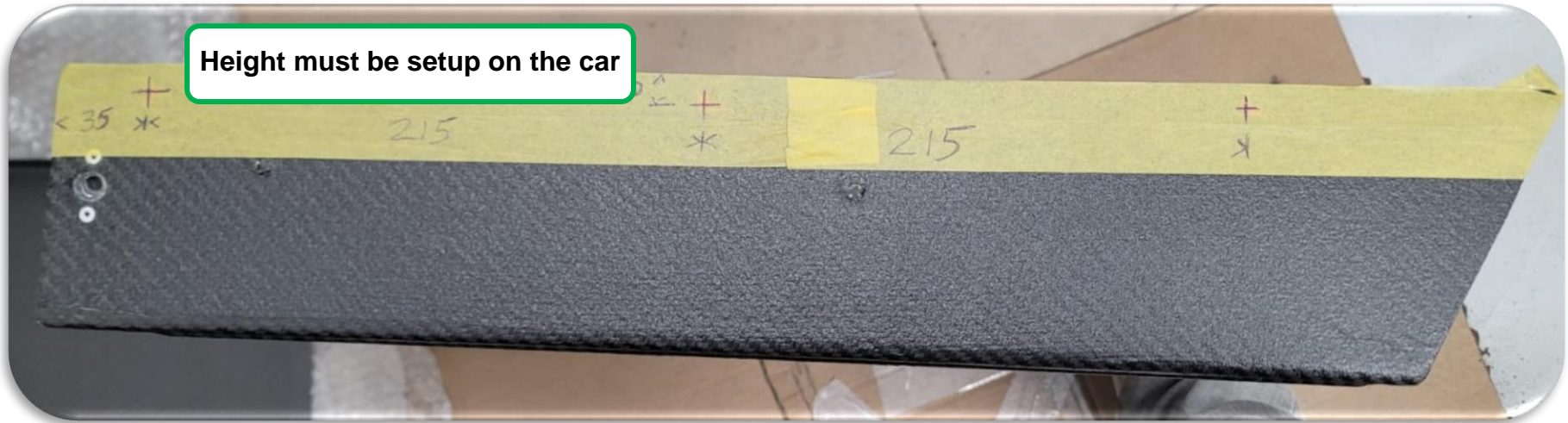

Height must be setup on the car

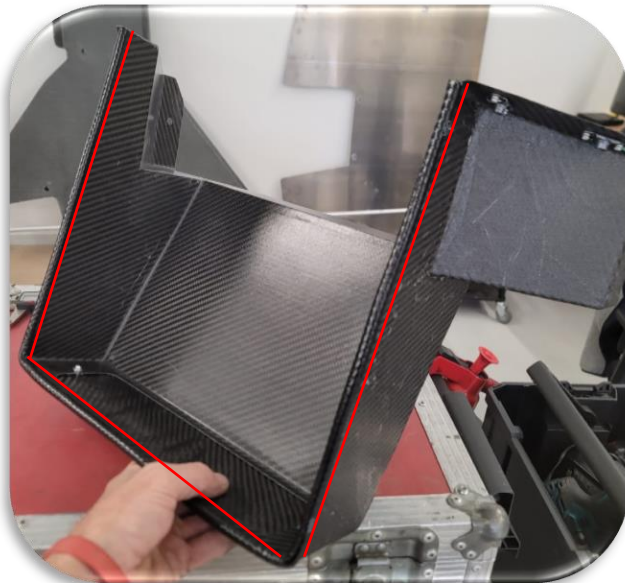

4014894 interface base, requiring some edging strip to prevent cutting the intercooler



# 6.3 COOLING – Overview

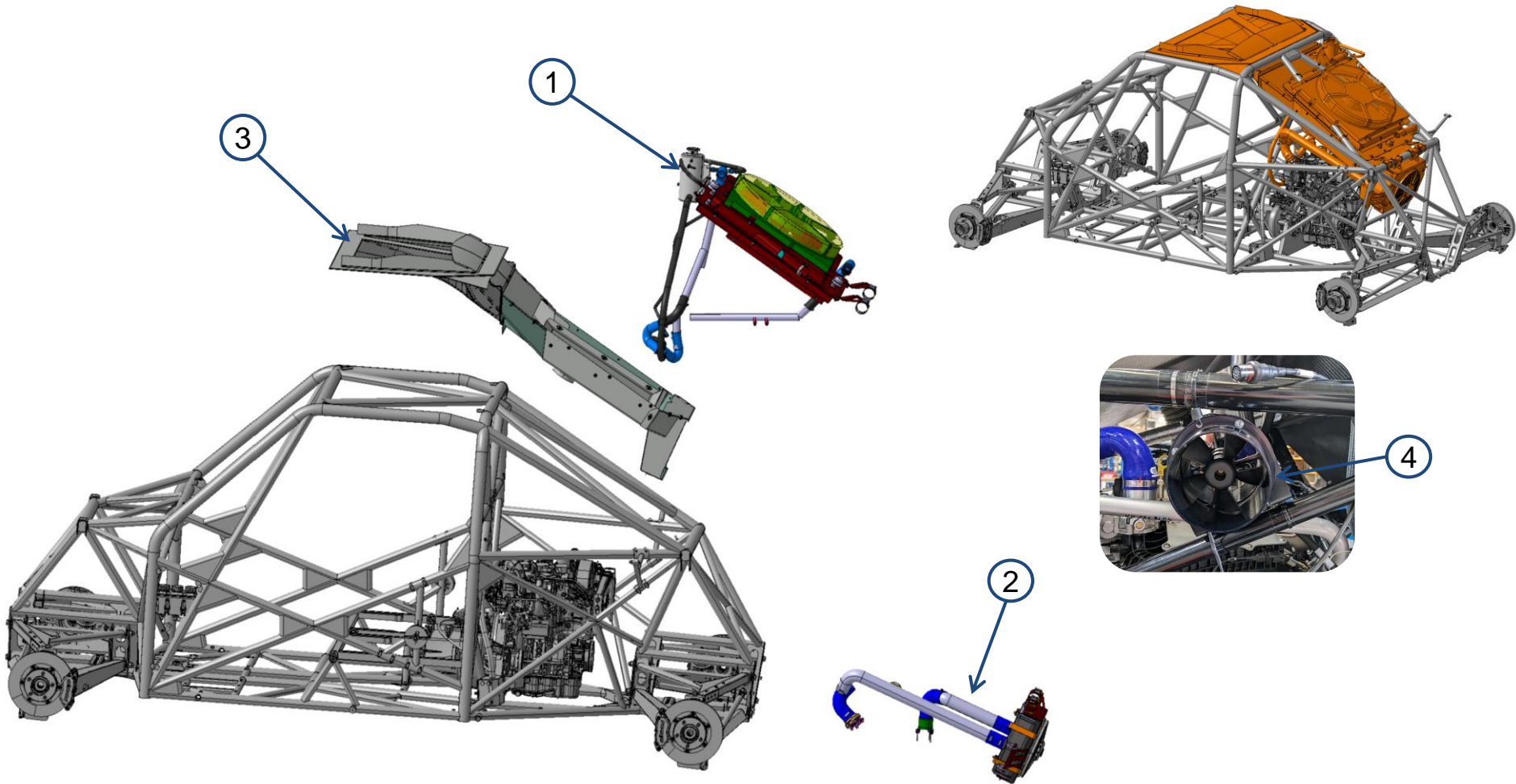

No.	Ref.	Name	Qty.
1	4012702	SASS-COOLING AIR / WATER	1
2	4013867	SASS-COOLING AIR /AIR	1
3	4013726	SASS-COMPONENT AIR VEIN COMPOSITE	1
4	4016545	SASS-COMPONENT GEARBOX FAN	1

## 6.3.1 COOLING – Air / Water – Bracket installation

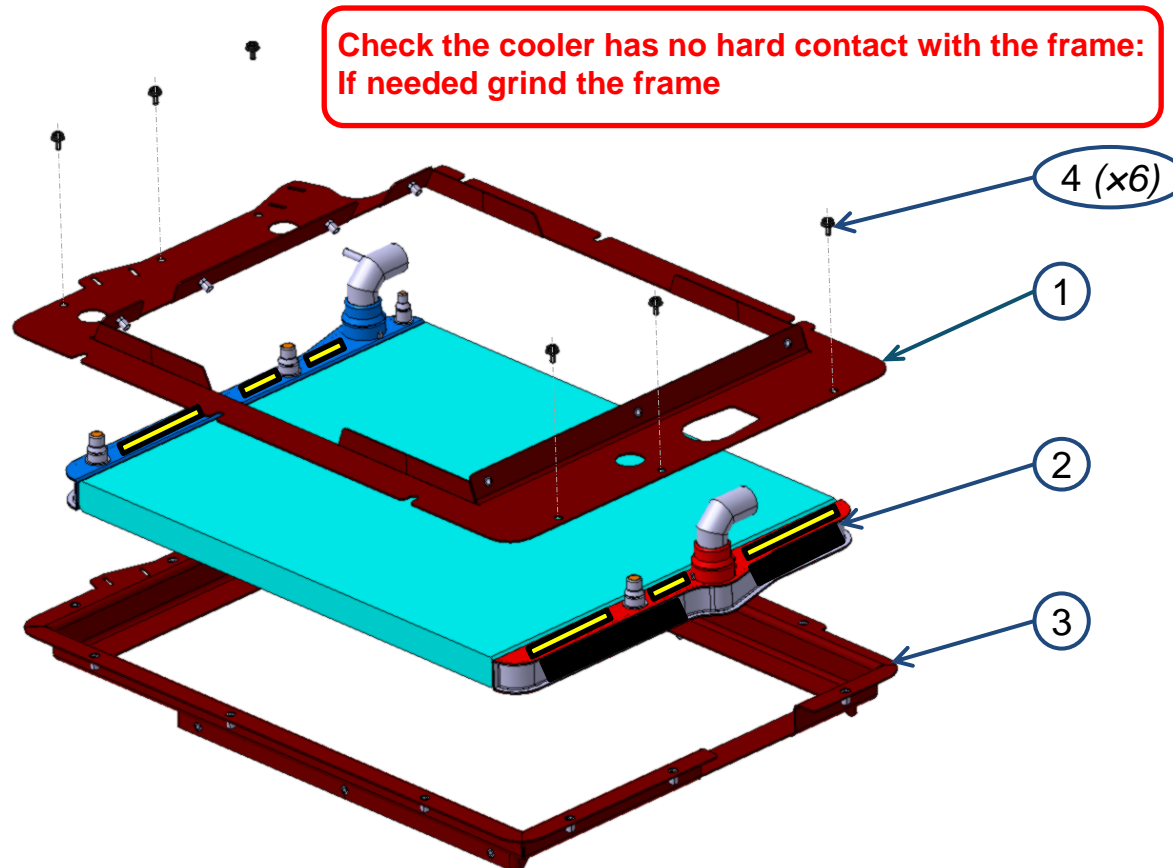

**Check the cooler has no hard contact with the frame:  
If needed grind the frame**

**Foam to protect the radiator:**

-  Add 2mm expanding foam (Wurtz KFZ) on both side of the radiator boxes
-  Add 25mm foam on the width on the radiator to close the gap with the frame

No.	Ref.	Name.	Qty.
1	4013581	SASS-COVER PLATE - BRACKET RADIATOR – WELDED	1
2	4016738	DRP-COMPONENT RADIATOR REWORKED	1
3	4013536	SASS-BRACKET RADIATOR – ASSEMBLY	1
4	4013690	COP-SCREW M6X12 HEX FLANGE HEAD RIBBED CL100 BLACK	6

## 6.3.2 COOLING – Air / Water – Bracket installation

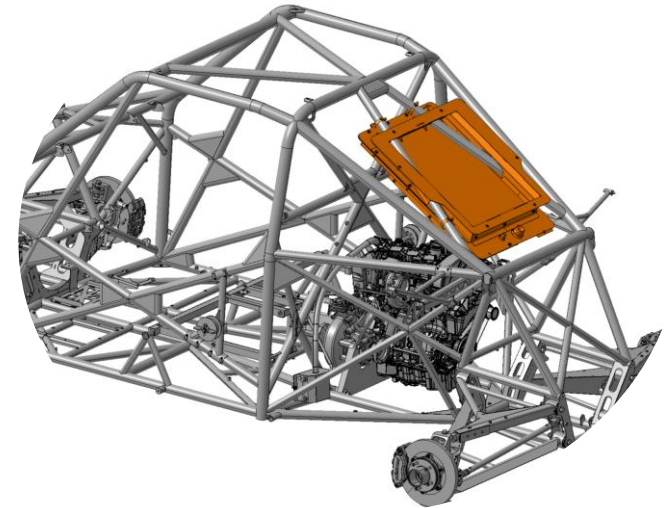
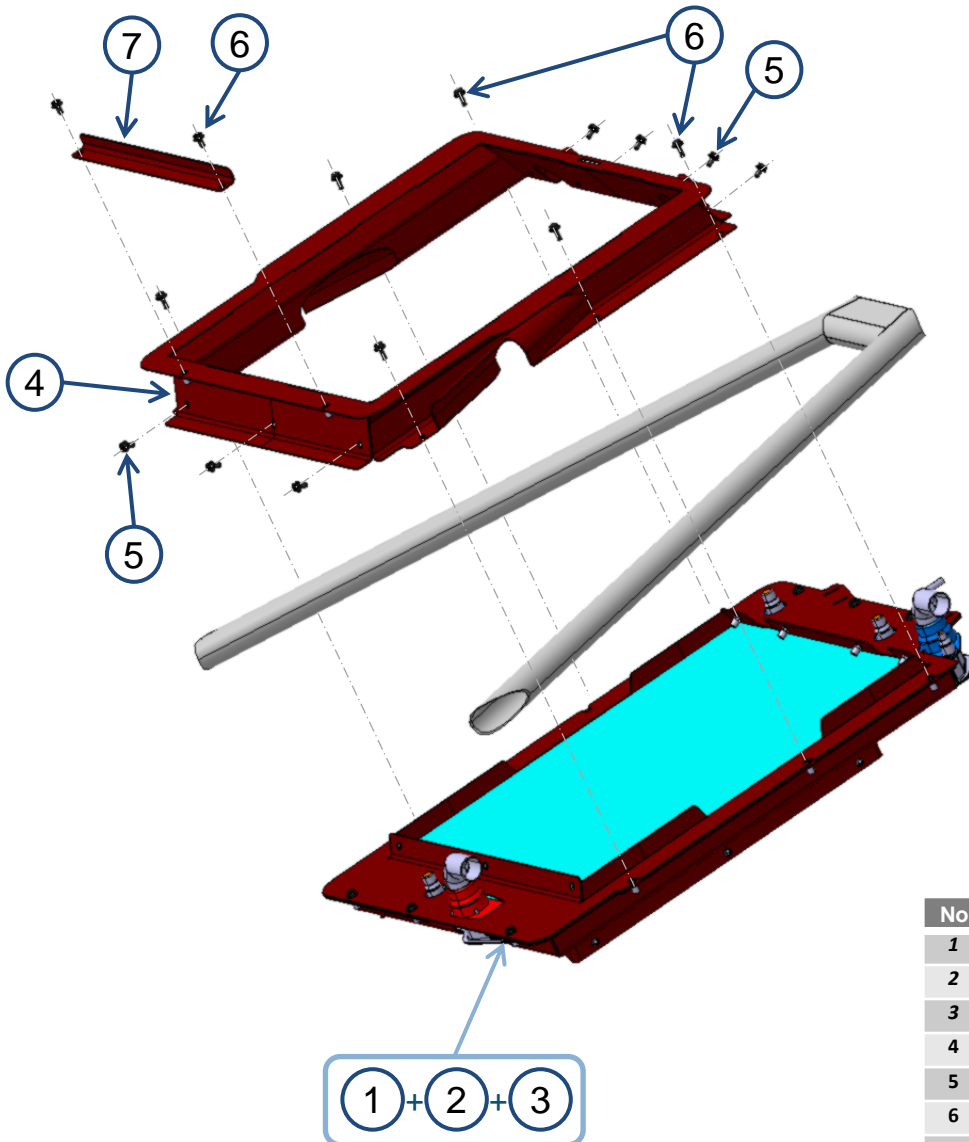

No.	Ref.	Name	Qty.
1	4013536	SASS-BRACKET RADIATOR	1
2	4012569	COP-RADIATOR	1
3	4013581	SASS-COVER PLATE - BRACKET RADIATOR	1
4	4013613	SASS-BRACKET FAN AND RADIATOR FIXING	1
5	4013690	COP-SCREW M6X12 HEX FLANGE HEAD RIBBED CL100 BLACK	9
6	4017102	COP-SCREW M6X16 HEX FLANGE HEAD RIBBED CL100 BLACK	6
7	4013511	DRP-SHEET BENDED – FAN FIXING – FAN BRACKET	1

# 6.3.4.1 COOLING – Air / Water – Fan installation

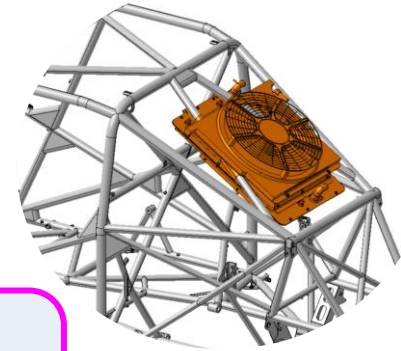
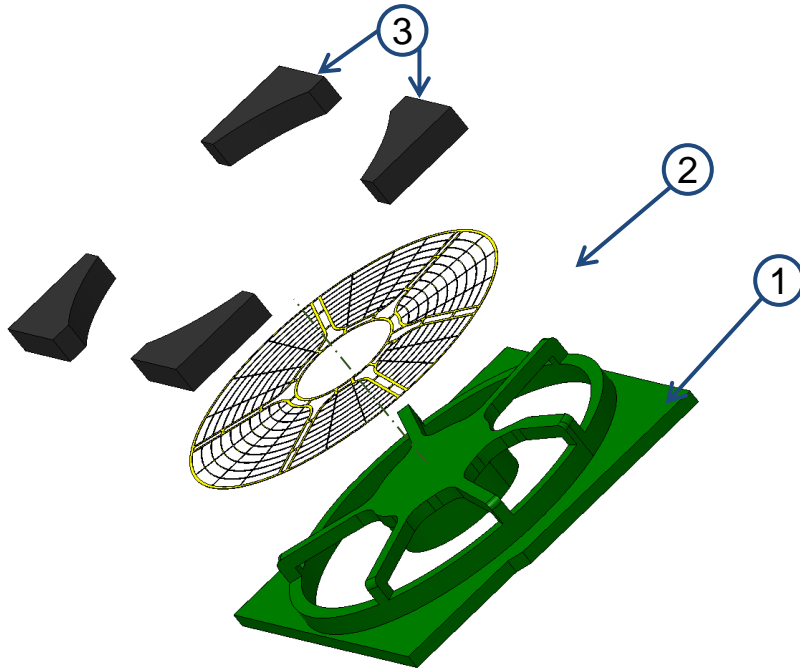

**Radiator fan assembly**

SECURE FOAM USING ZIP TIES, MAKE SURE THE FOAM IS WELL PRESSED AGAINST THE FAN (YOU MAY REWORK FOAM IF NEEDED)

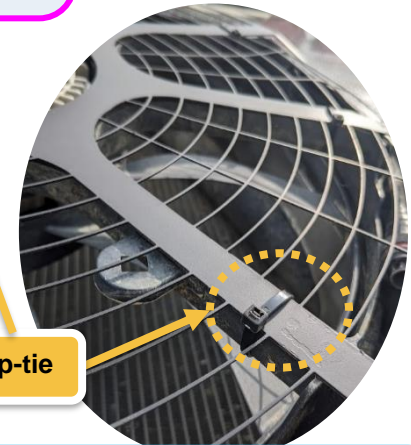
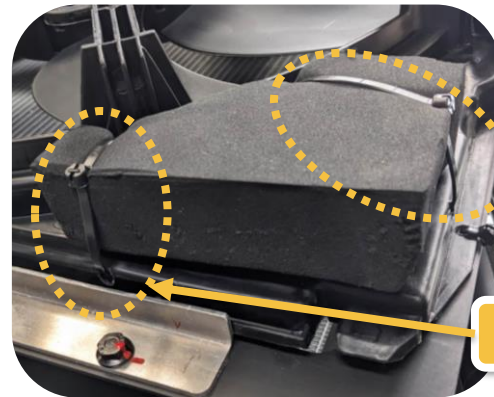

**Zip-tie**

**Radiator fan assembly**

SECURE FAN GUARD TO FAN USING ZIP TIES

No.	Ref.	Name	Qty.
1	4017874	SASS-COMPONENT WIRED WATER COOLING FAN	1
2	4017469	DRP-COMPONENT WATER FAN GUARD	1
3	4018009	DRP-FOAM WATER COOLING FAN	4

## 6.3.4.2 COOLING – Air / Water – Fan installation

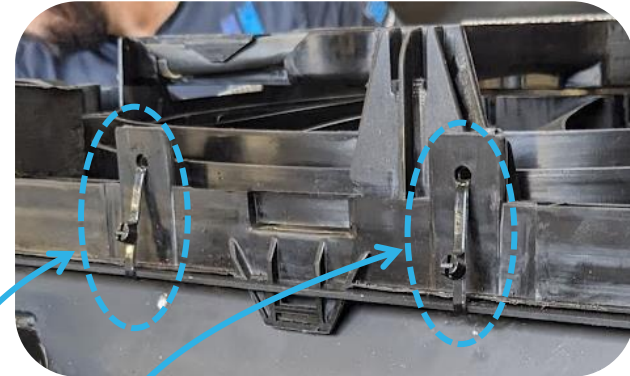
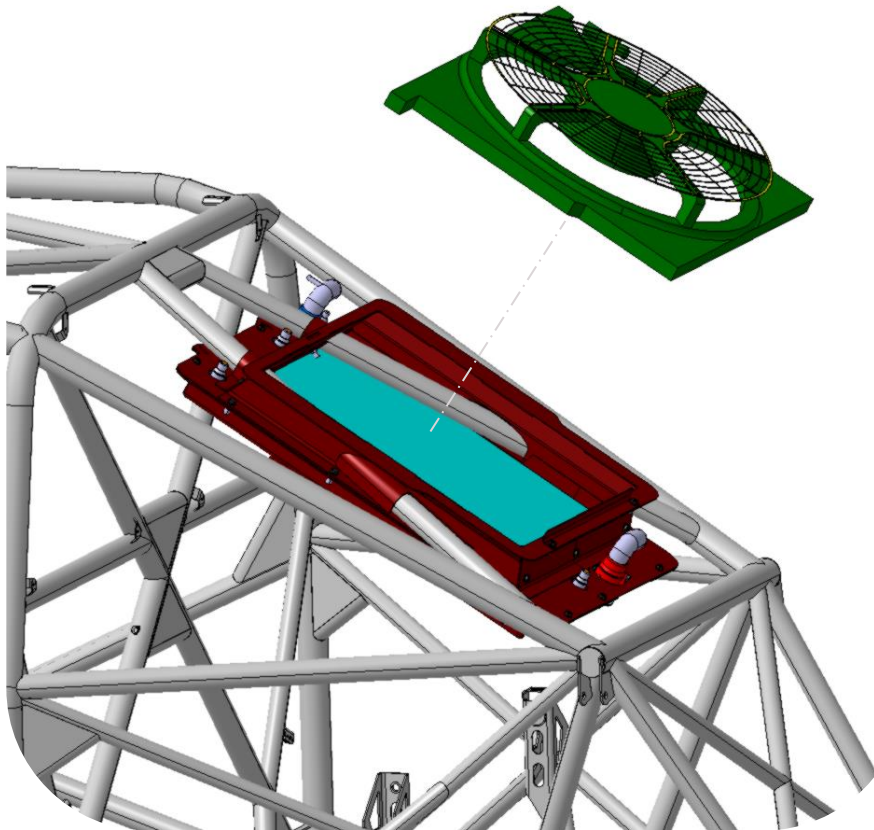
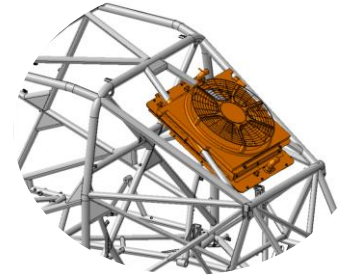

Radiator fan assembly

SECURE THE FAN ASSEMBLY TO THE RADIATOR ASSEMBLY USING ZIP TIES AND THE HOLES MADE PREVIOUSLY.



No.	Ref.	Name	Qty.
1	4017874	SASS-COMPONENT WIRED WATER COOLING FAN	1

## 6.3.4 COOLING – Air / Water – Expansion tank

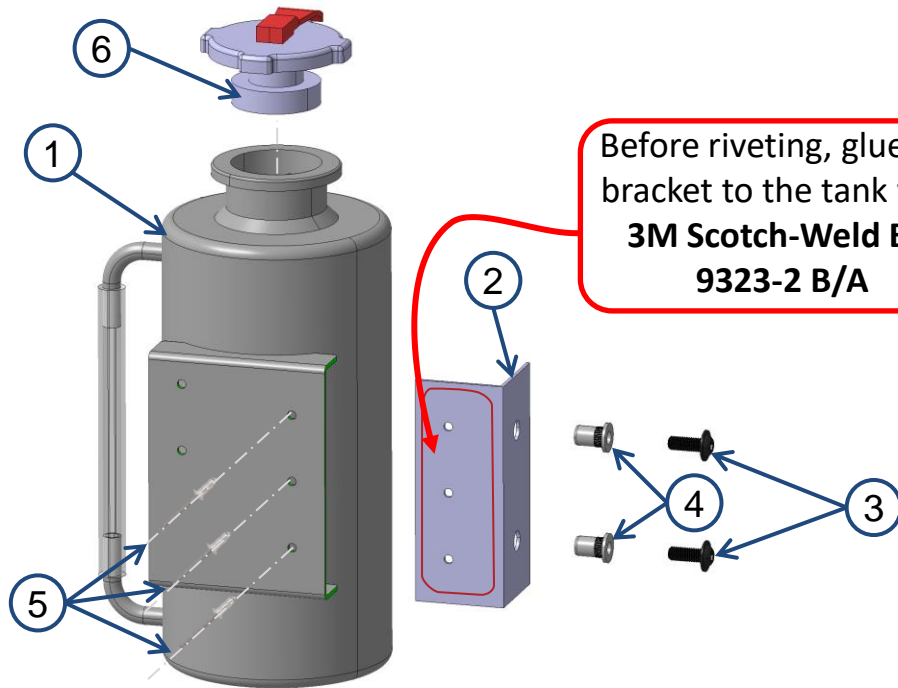

Before riveting, glue the bracket to the tank with **3M Scotch-Weld EC-9323-2 B/A**

When placing the expansion tank, make sure that the expansion tank's upper tube is above the radiators upper point.

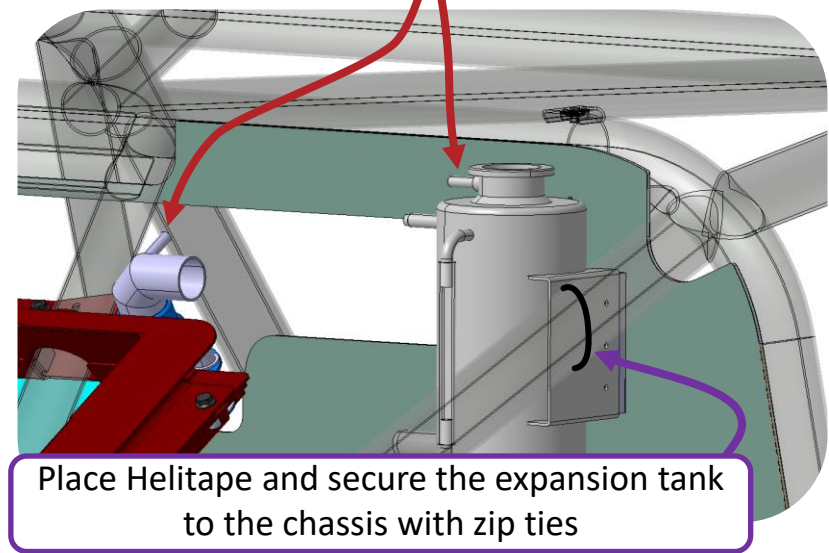

No.	Ref.	Name	Qty.
1	4014806	DRP-TANK COOLANT EXPANSION 1.5L – REWORKED	1
2	4017532	DRP-COMPONENT TANK BRACKET	1
3	4013372	COP-SCREW TBHC EMBASE M6×16 INOX A2	2
4	4014808	COP-INSERT TAPPED M6 – ROUND SHAPE	2
5	4013908	COP-RIVETS ALUMINIUM Ø4×10	3
6	4014103	COP-PLUG VASE EXPANSION	1

## 6.3.6 COOLING – Air / Water – Cooling circuit – Expansion circuit details

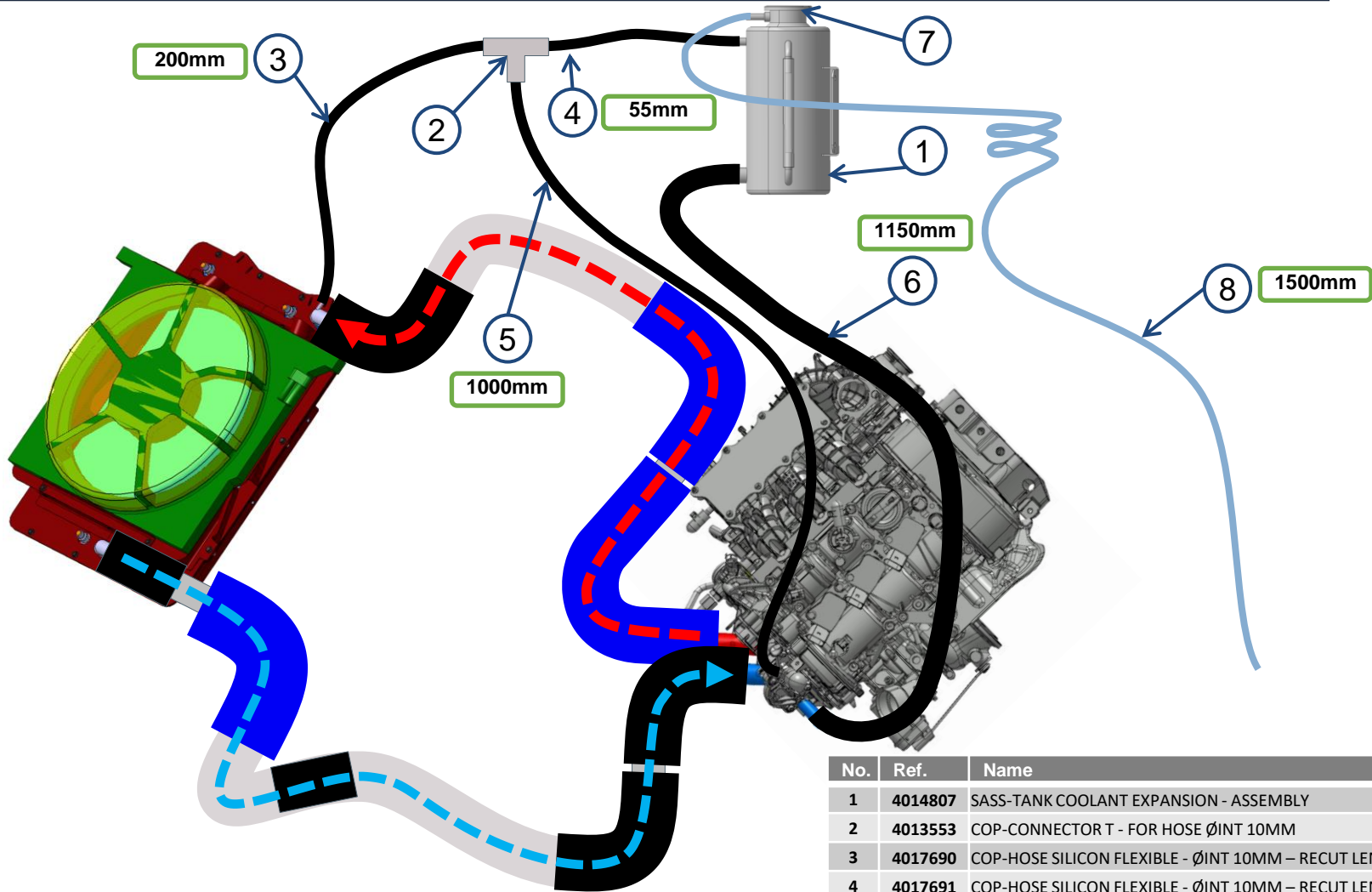

No.	Ref.	Name	Qty.
-	4013505	COP-HOSE CLAMP 20 - 32 MM	2
-	4013507	COP-HOSE CLAMP 12 - 22 MM	5
-	4014699	COP-HOSE CLAMP	1

No.	Ref.	Name	Qty.
1	4014807	SASS-TANK COOLANT EXPANSION - ASSEMBLY	1
2	4013553	COP-CONNECTOR T - FOR HOSE ØINT 10MM	1
3	4017690	COP-HOSE SILICON FLEXIBLE - ØINT 10MM – RECUT LENGTH 200mm	1
4	4017691	COP-HOSE SILICON FLEXIBLE - ØINT 10MM – RECUT LENGTH 55mm	1
5	4017692	COP-HOSE SILICON FLEXIBLE - ØINT 10MM – RECUT LENGTH 1000mm	1
6	4017693	COP-HOSE SILICON FLEXIBLE - ØINT 20MM – RECUT LENGTH 1150mm	1
7	4014103	COP-PLUG VASE EXPANSION	1
8	4017694	COP-HOSE TRANSPARENT - ØINT 8MM – RECUT LENGTH 1500mm	1

# 6.3.7 COOLING – Air / Water – Cooling circuit – Cold and warm details

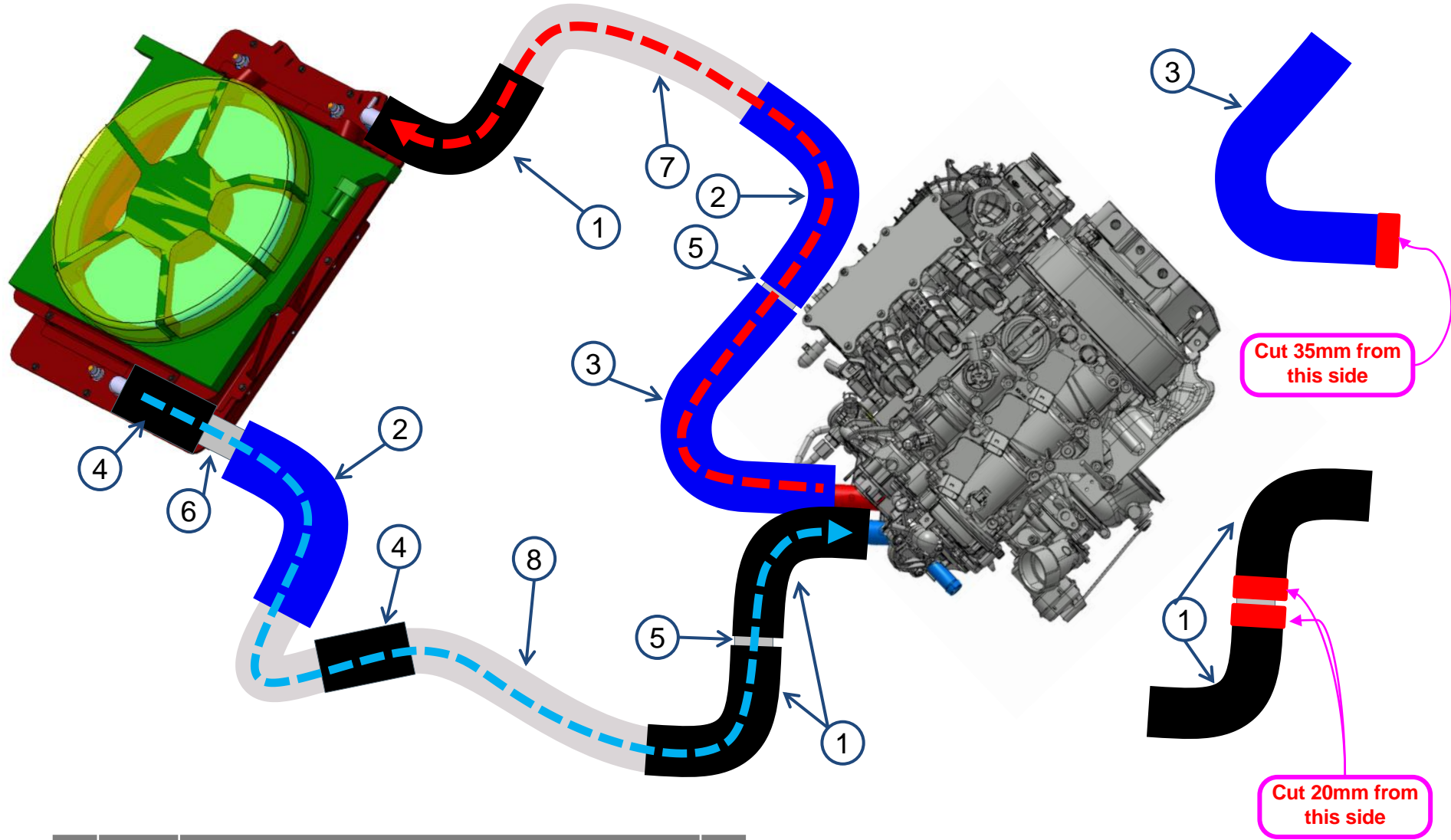

No.	Ref.	Name	Qty.
-	4015025	COP-HOSE CLAMP	14
-			



## 6.3.8 COOLING – Air / Water – Cooling circuit – Cold

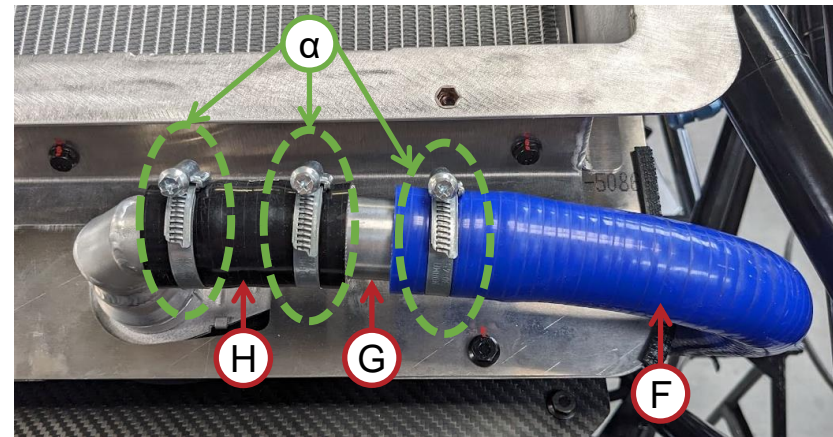
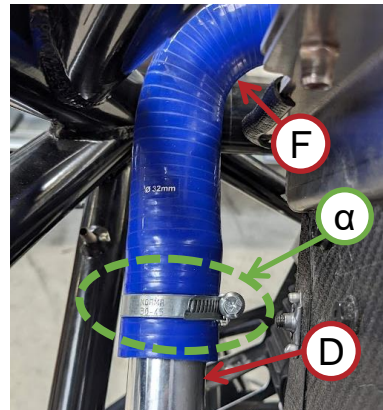
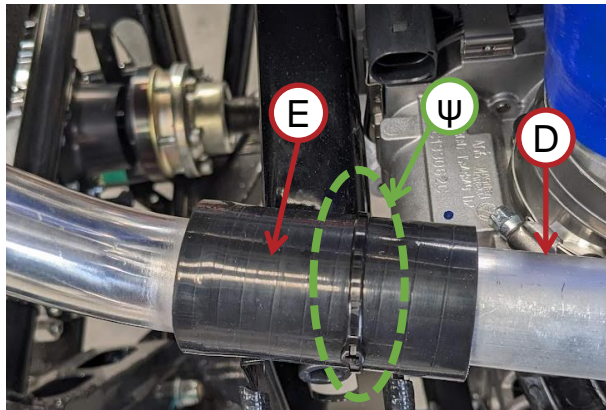
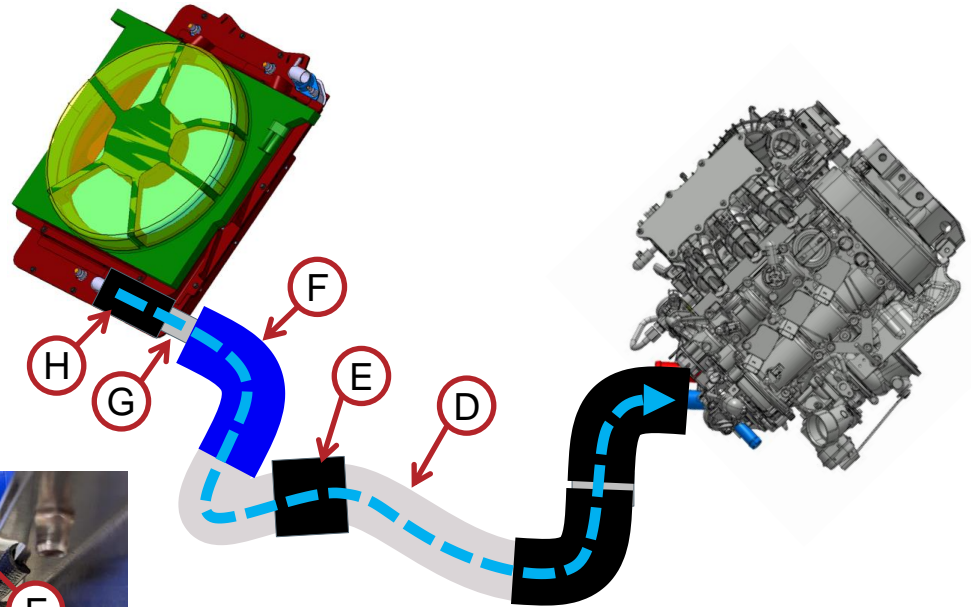
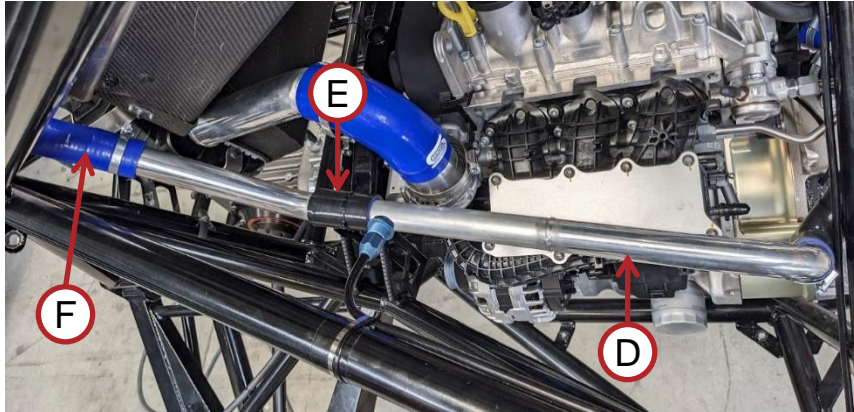

Ltr.	Ref.	Name
D	4016760	SASS-COMPONENT WARM WATER PIPE WELDED
E	4013497	COP-HOSE SILICON - ØINT 32MM - STRAIGHT L75MM - BLACK
F	4013905	COP-HOSE SILICON - ØINT 32MM - ELBOW 90° - ARM LENGTH 150MM
G	4016817	DRP-PIPE ALUMINIUM Ø32MM - L100
H	4013497	COP-HOSE SILICON - ØINT 32MM - STRAIGHT L75MM - BLACK
α	4015025	COP-HOSE CLAMP TORRO_9_ZINGUE_30-45MM
ψ		Zip-tie (TAILLE)

## 6.3.9 COOLING – Air / Water – Cooling circuit – Cold

Ltr.	Ref.	Name
A	4013495	COP-HOSE SILICON - ØINT 32 - ELBOW 90° - BLACK
B	4013495	COP-HOSE SILICON - ØINT 32 - ELBOW 90° - BLACK
C	4016818	DRP-PIPE ALUMINIUM Ø32MM - L50
D	4016760	SASS-COMPONENT WARM WATER PIPE WELDED
p	-	Cravatte
α	4015025	COP-HOSE CLAMP

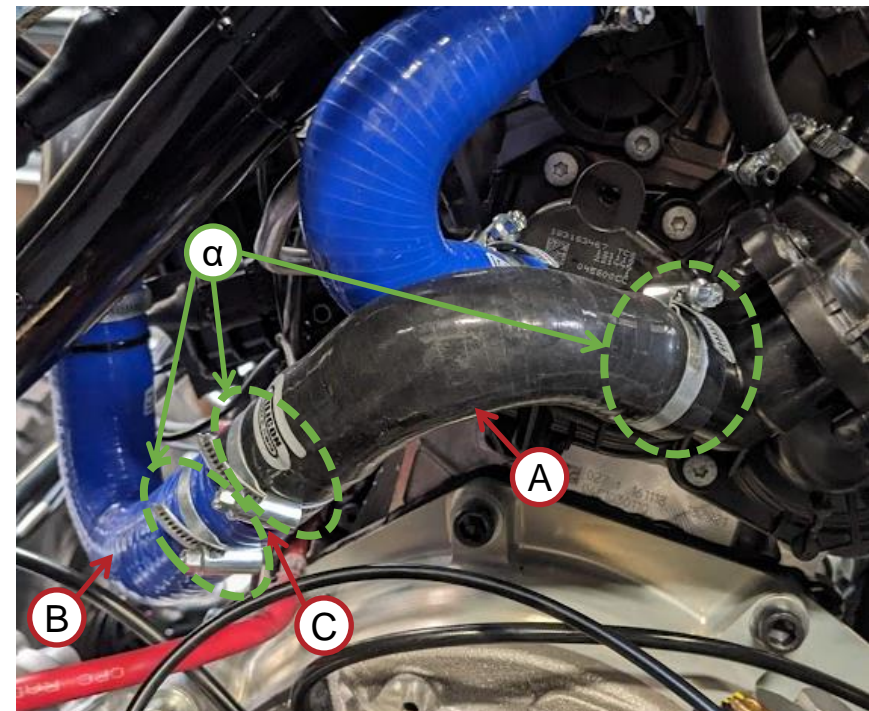
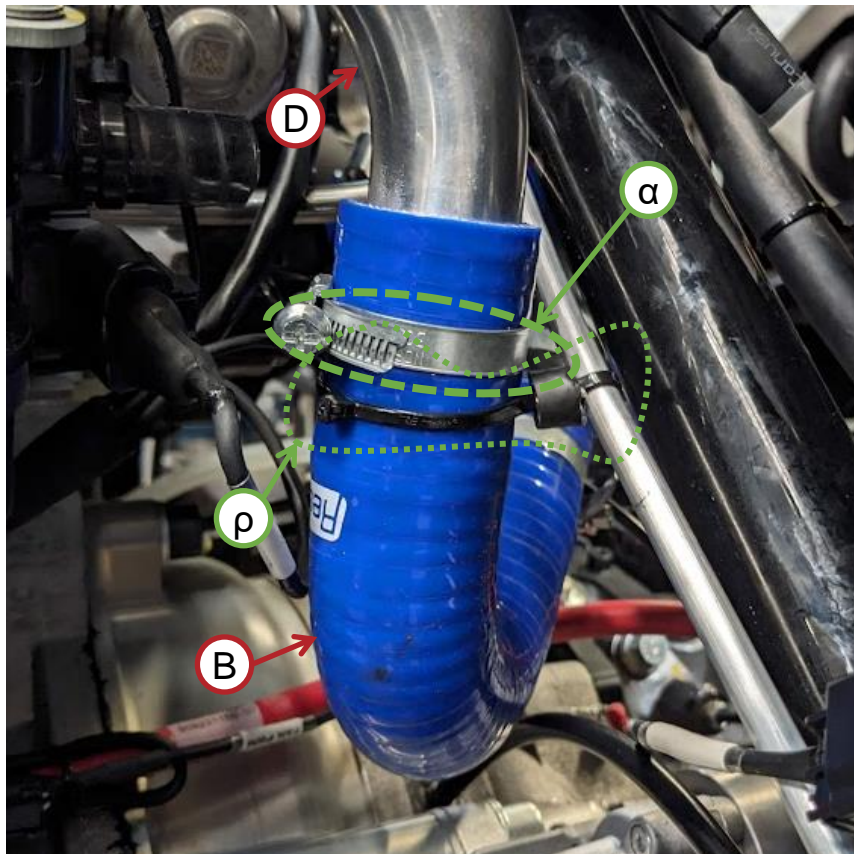
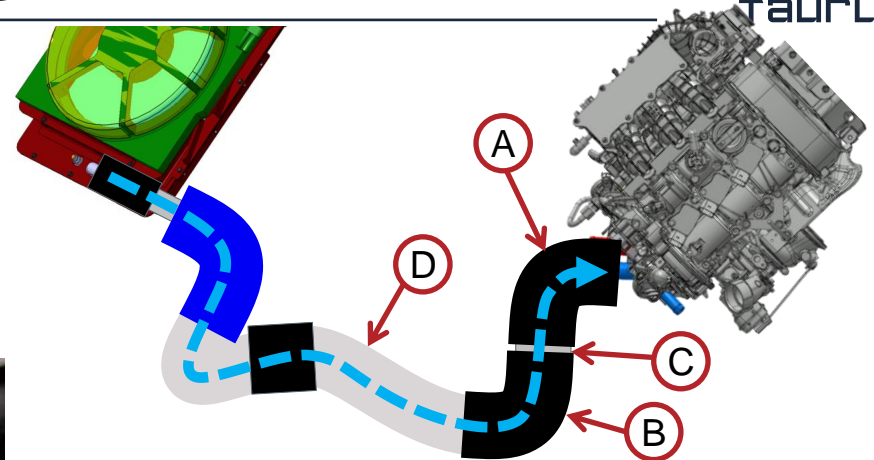

## 6.3.10 COOLING – Air / Water – Cooling circuit – Hot

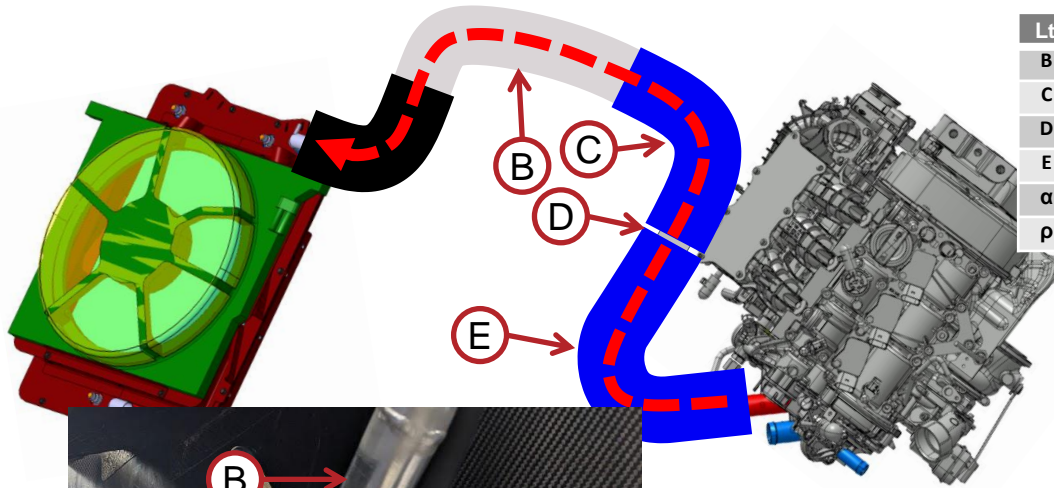

Ltr.	Ref.	Name
B	4016759	SASS-COMPONENT FRESH WATER PIPE WELDED
C	4013905	COP-HOSE SILICON - ØINT 32MM - ELBOW 90° - ARM LENGTH 150MM
D	4016818	DRP-PIPE ALUMINIUM Ø32MM - L50
E	4013907	COP-HOSE SILICON - ØINT 32MM - ELBOW 135°
α	4015025	COP-HOSE CLAMP TORRO_9_ZINGUE_30-45MM
ρ		Cravate

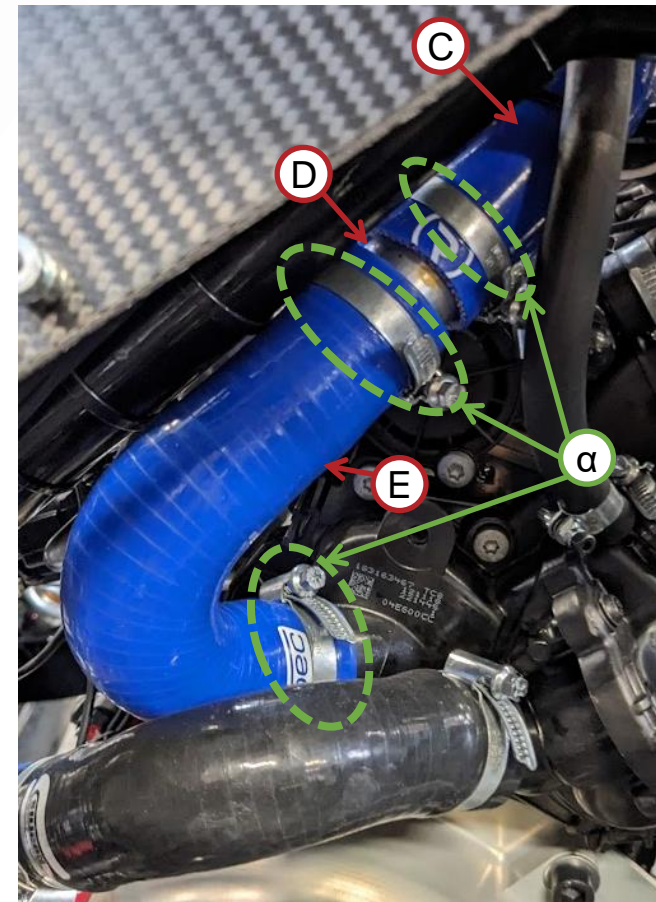
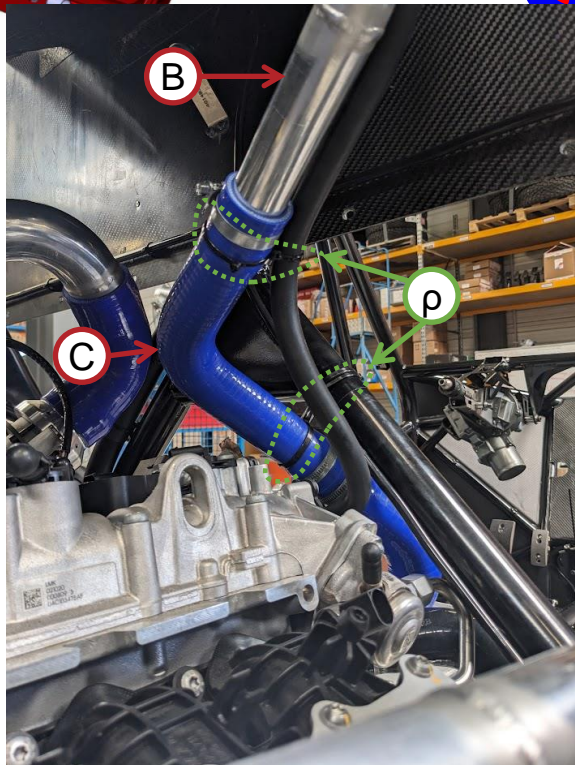

## 6.3.11 COOLING – Air / Water – Cooling circuit – Hot

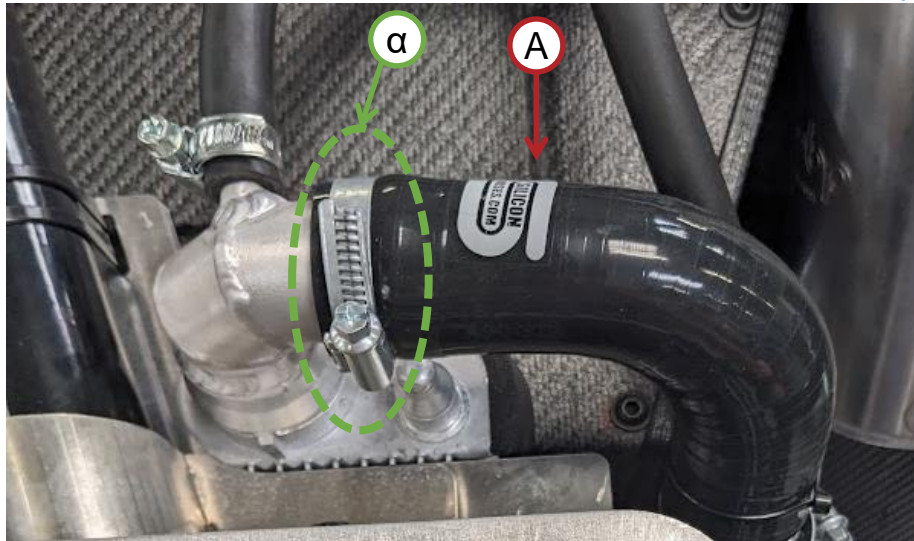
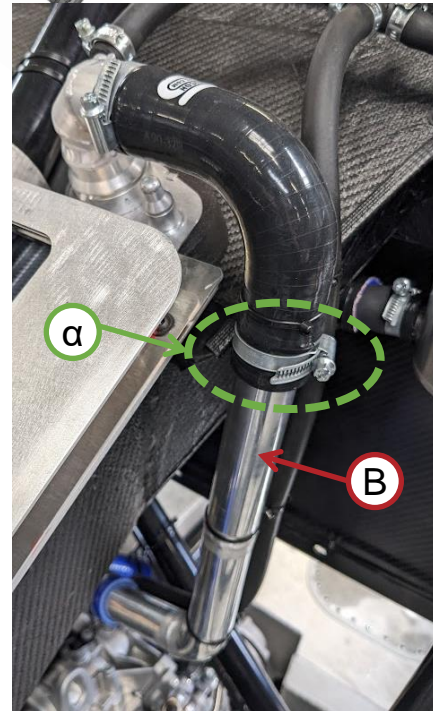
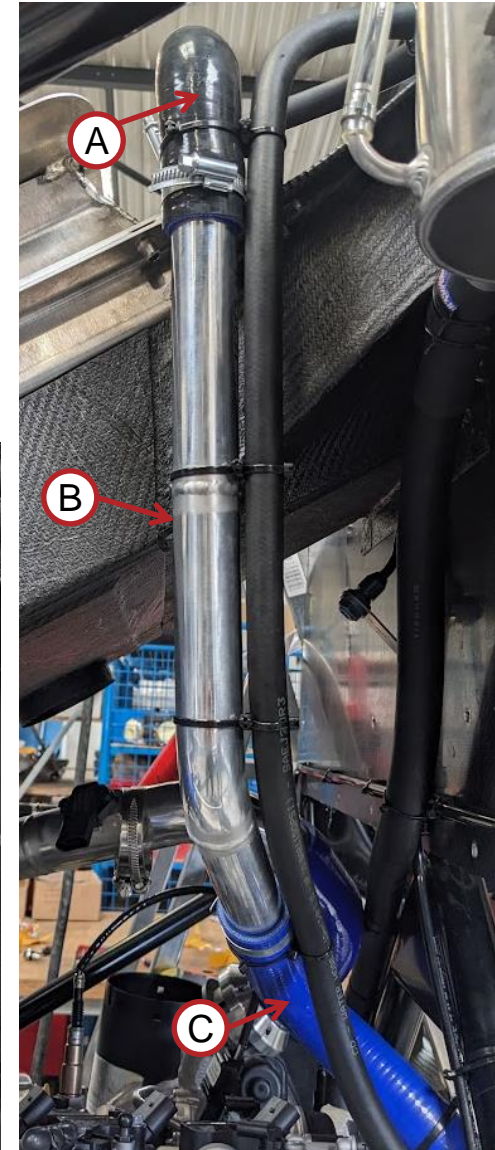
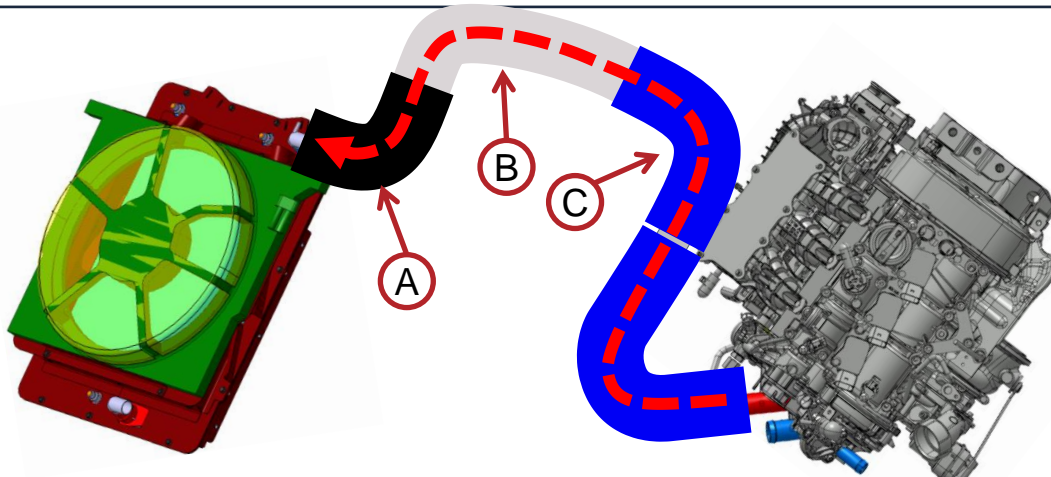

Ltr.	Ref.	Name
A	4013495	COP-HOSE SILICON - ØINT 32 - ELBOW 90° - BLACK
B	4016759	SASS-COMPONENT FRESH WATER PIPE WELDED
C	4013905	COP-HOSE SILICON - ØINT 32MM - ELBOW 90° - ARM LENGTH 150MM
α	4015025	COP-HOSE CLAMP TORRO_9_ZINGUE_30-45MM

## 6.3.12 COOLING – Air / Water – Cooling circuit – Expansion

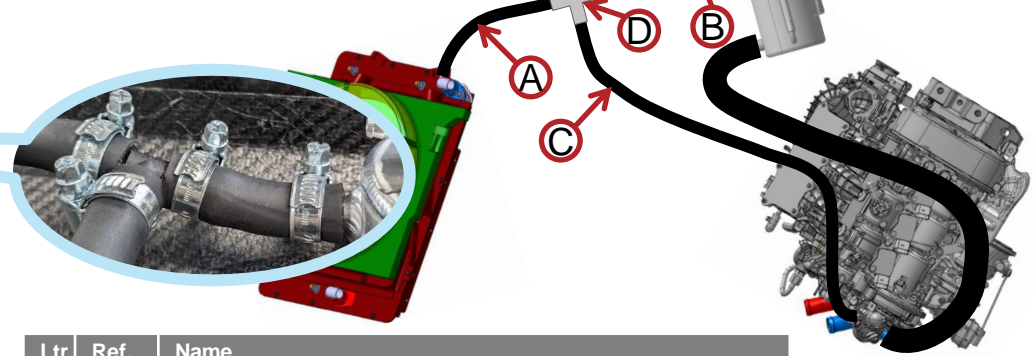
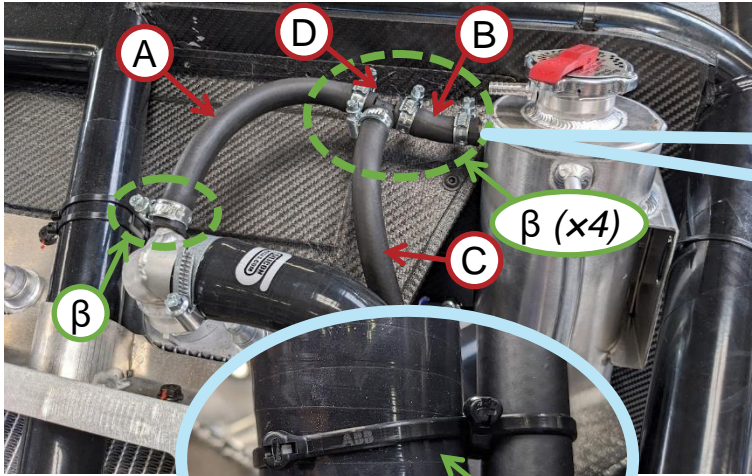

Ltr.	Ref.	Name
A	4017690	COP-HOSE SILICON FLEXIBLE - ØINT 10MM – RECUT LENGTH 200mm
B	4017691	COP-HOSE SILICON FLEXIBLE - ØINT 10MM – RECUT LENGTH 55mm
C	4017692	COP-HOSE SILICON FLEXIBLE - ØINT 10MM – RECUT LENGTH 1000mm
D	4013553	COP-CONNECTOR T - FOR HOSE ØINT 10MM
ψ	-	Zip-tie
β	4013507	COP-HOSE CLAMP
ε	4014699	COP-HOSE CLAMP

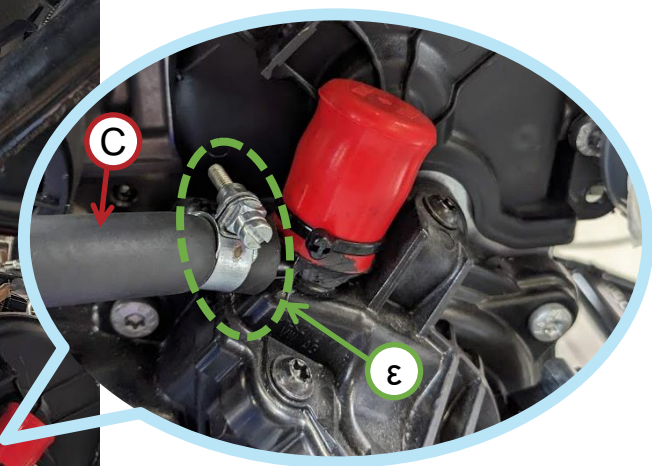
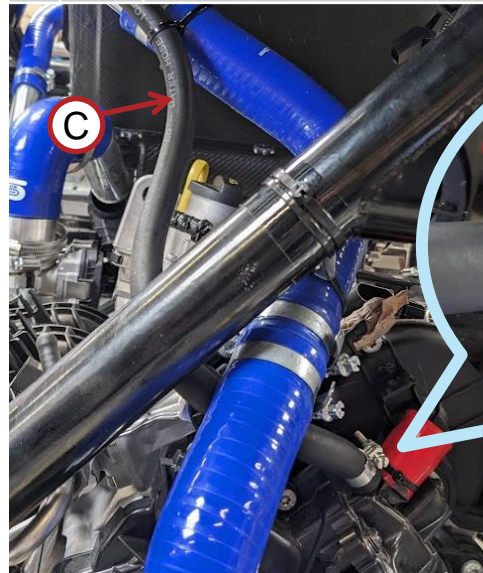
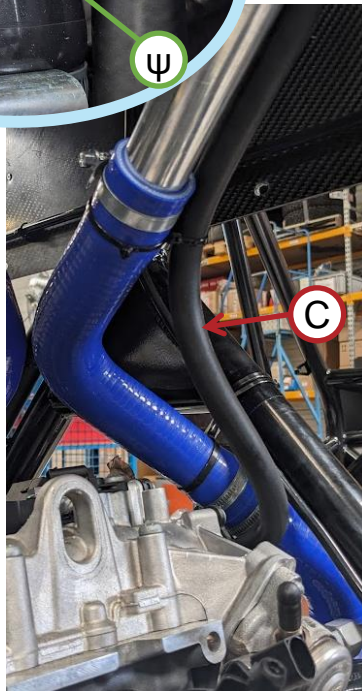
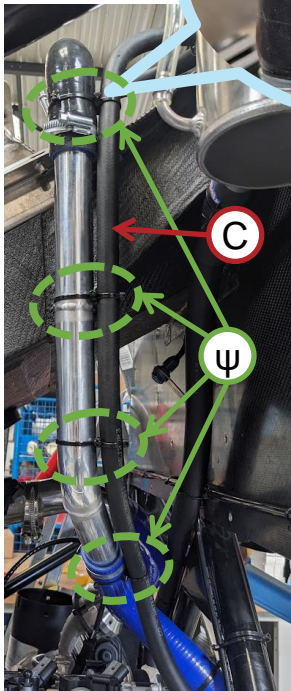

## 6.3.13 COOLING – Air / Water – Cooling circuit – Expansion

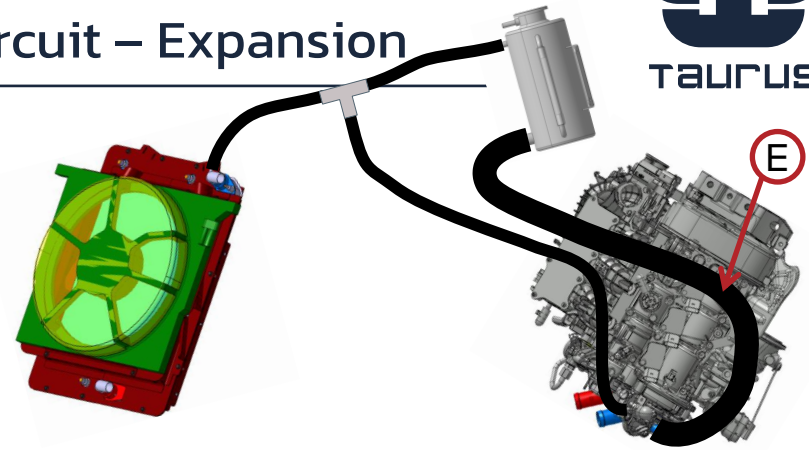
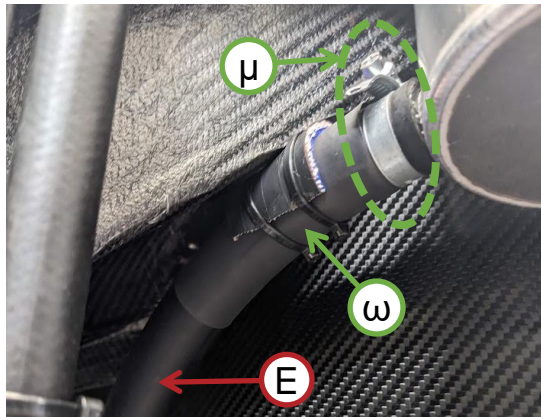

Ltr.	Ref.	Name
E	4017693	COP-HOSE SILICON FLEXIBLE - ØINT 20MM – RECUT LENGTH 1150mm
φ	-	Gain thermo + 2 Zip-ties
μ	4013505	COP-HOSE CLAMP 20 - 32 MM
ω	-	Gain thermo + 2 Zip-ties

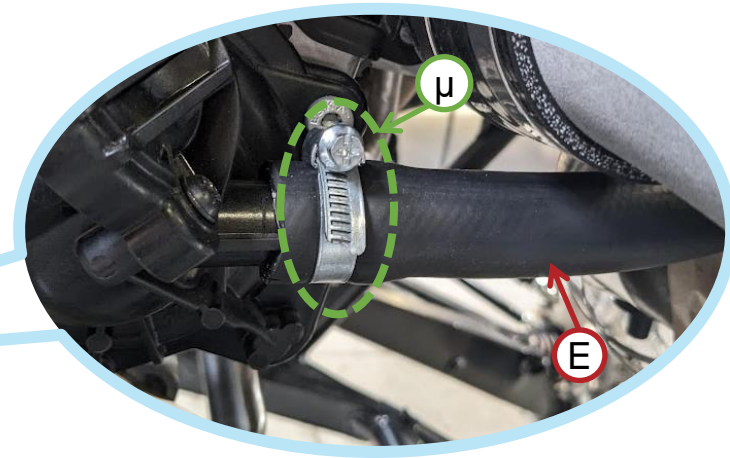
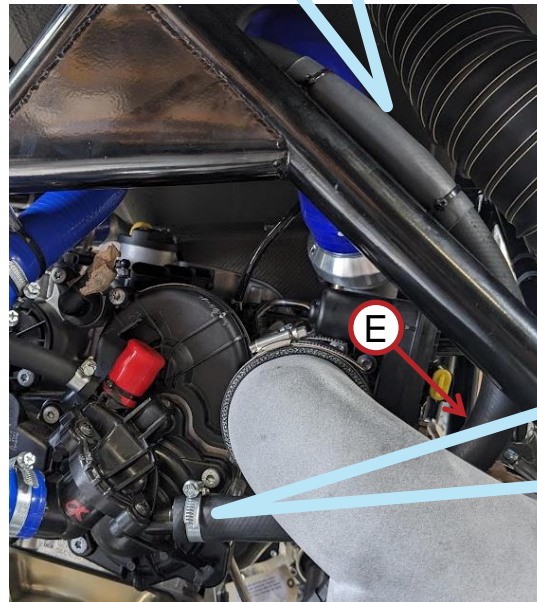
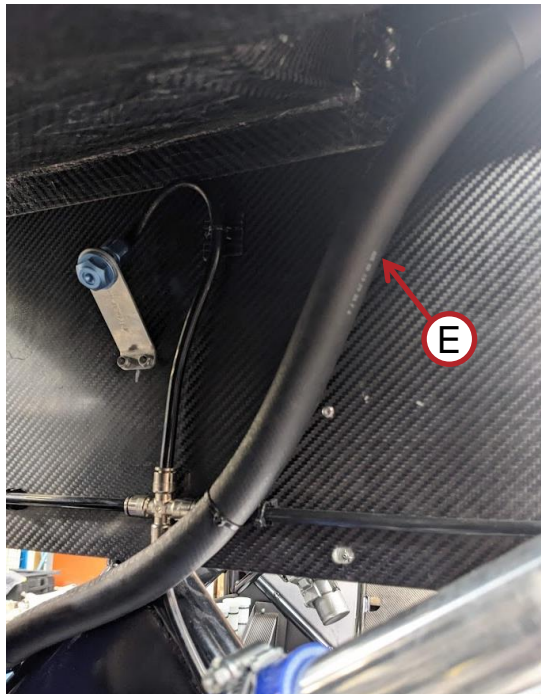

# 6.3.14 COOLING – Air / Water – Cooling circuit – Expansion

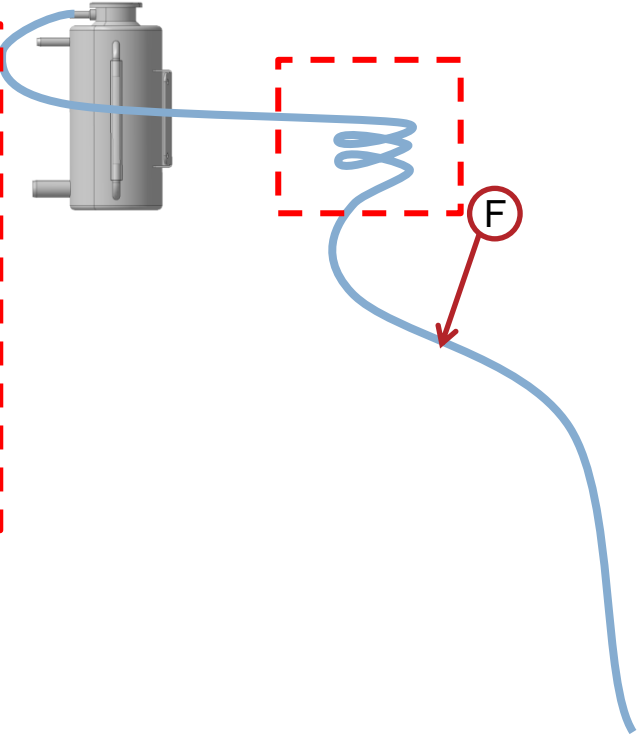
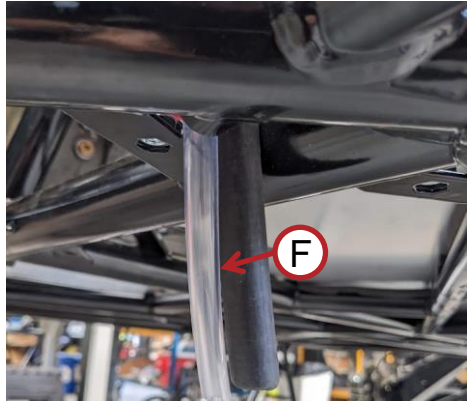
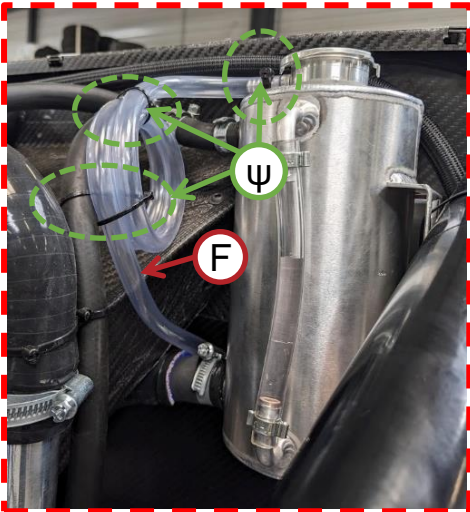
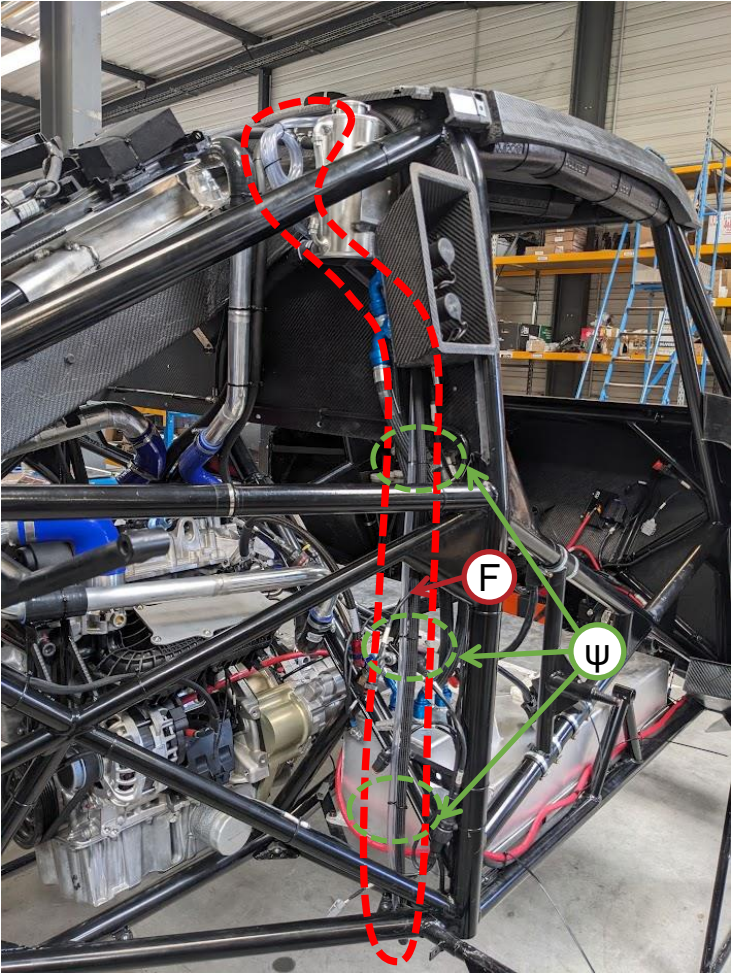

Ltr.	Ref.	Name
F	4017694	COP-HOSE TRANSPARENT - ØINT 8MM – RECUT LENGTH 1500mm
Ψ	-	Zip-tie

# 6.5.1 COOLING – Air / Air – Overview

CANAM intercooler

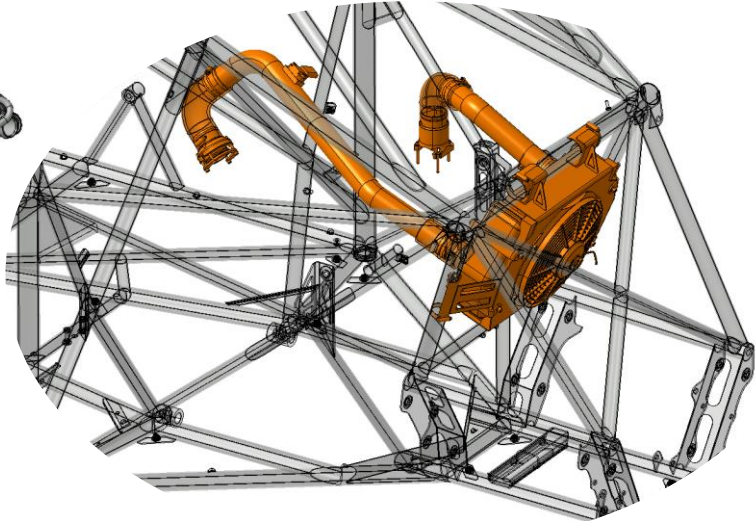
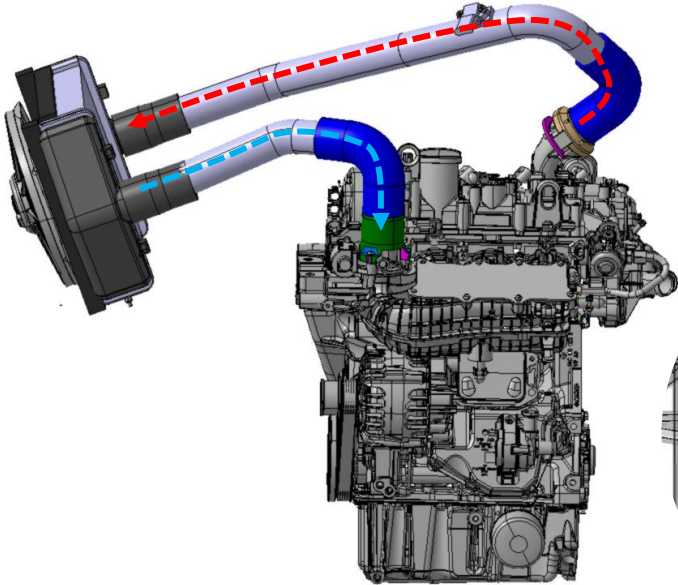
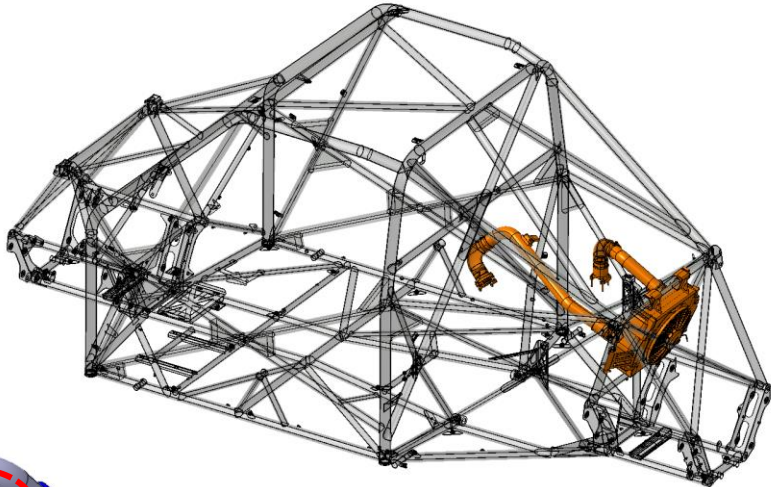
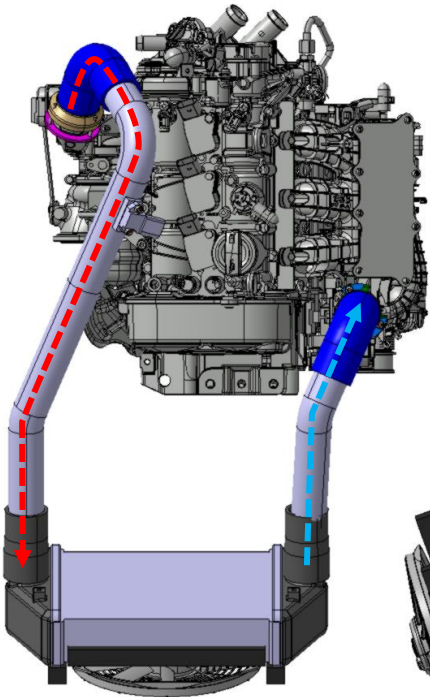



## 6.5.2 COOLING – Air /Air – Fixing to chassis

CANAM intercooler

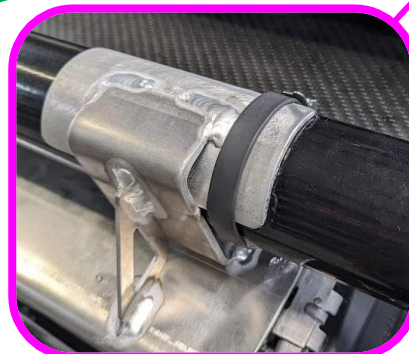
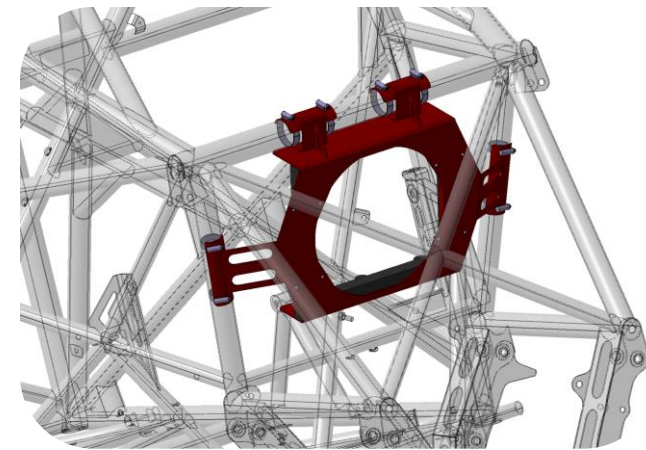
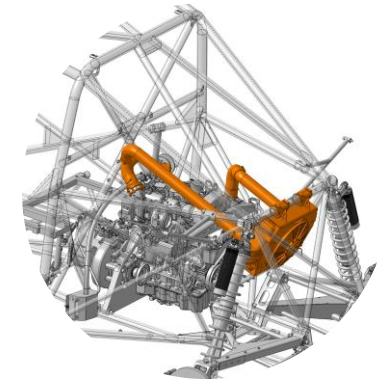
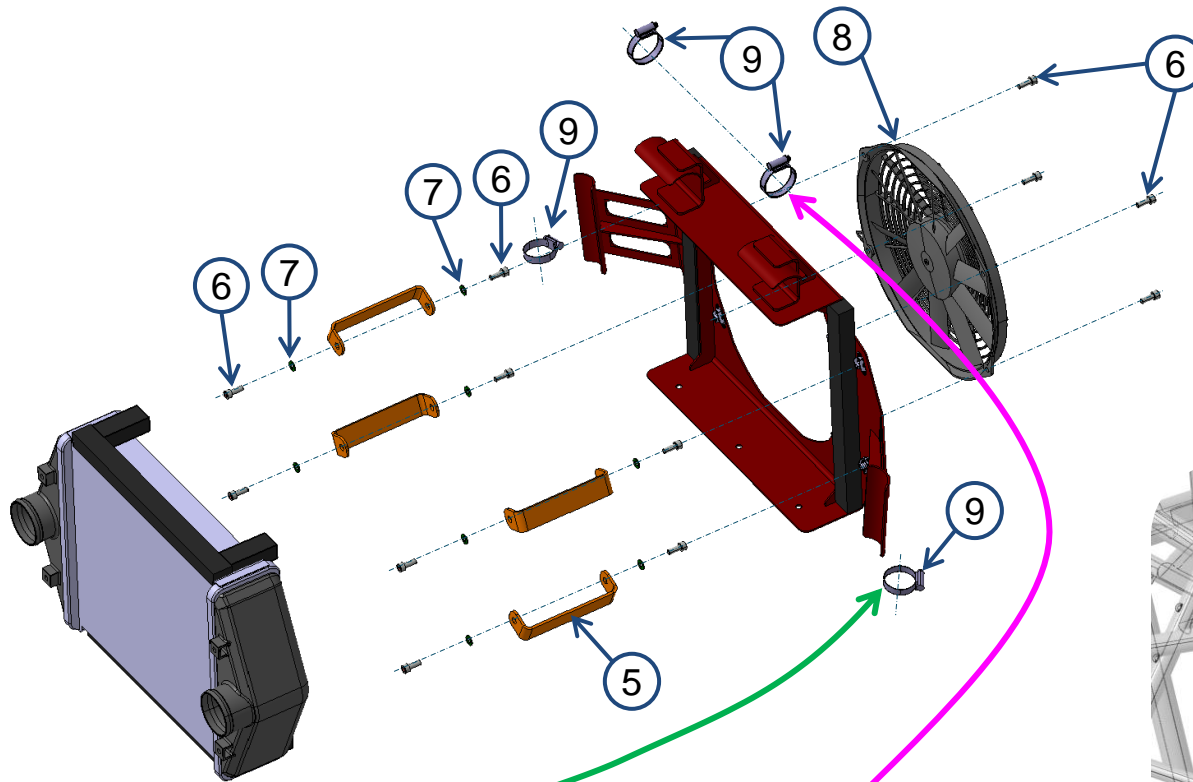

No.	Ref.	Name	Qty.
5	4013985	DRP-SHEET RADIATOR INTERFACE - BRACKET AIR / AIR EXCHANGER	4
6	4000584	SUP-HEXAGONAL SOCKET CAP SCREW	12
7	4009150	SUP-PLAIN WASHER	8
8	4017593	DRP-WIRED RAS FAN Ø 255MM	1
9	4021800	COP-HOSE CLAMP	4

## 6.5.3 COOLING – Air / Air– Foam installation

### CANAM intercooler

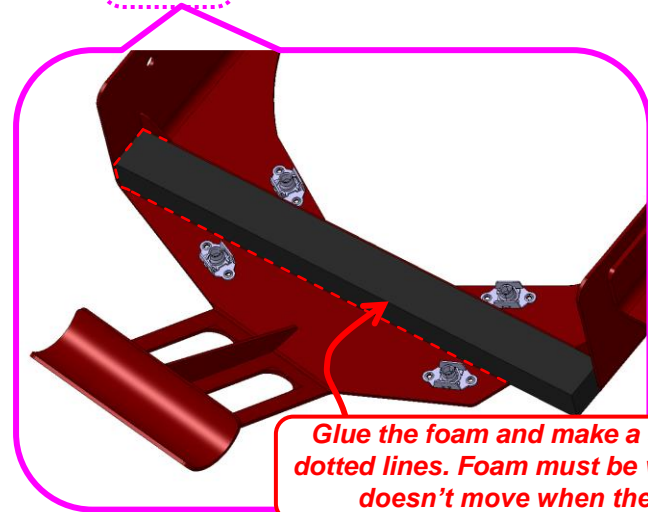
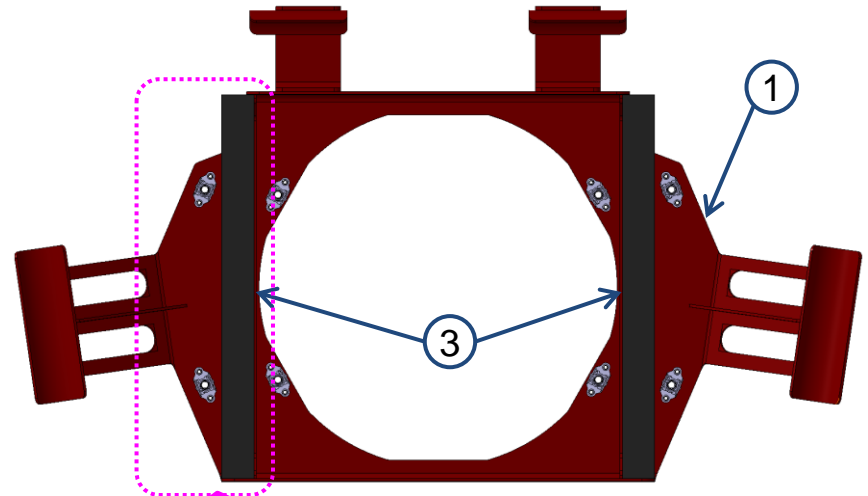
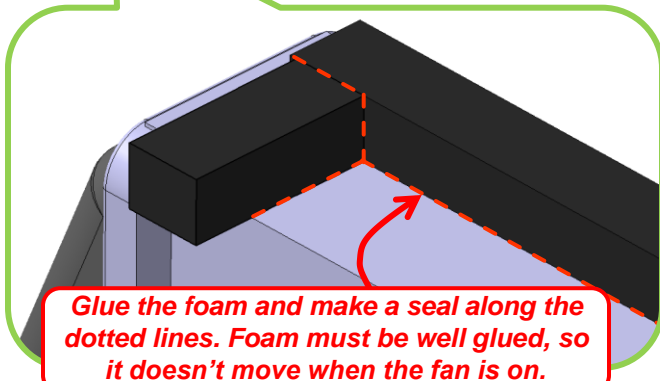
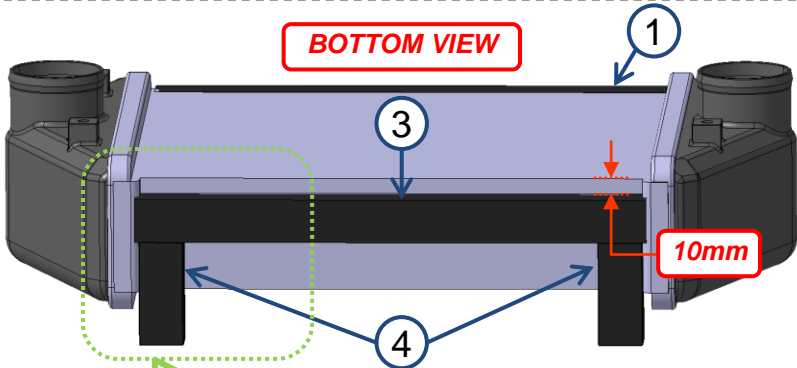
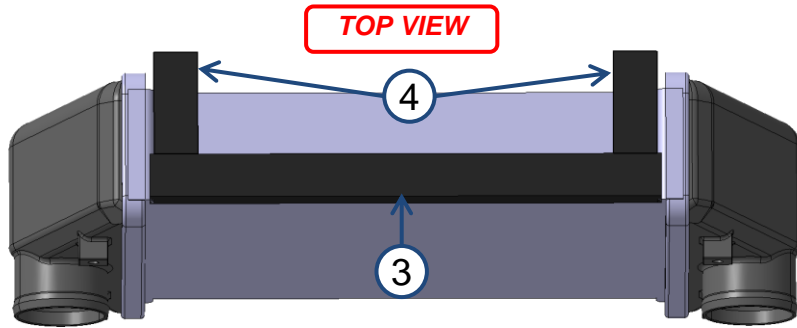

No.	Ref.	Name	Qty.
1	4014429	SASS-BRACKET AIR / AIR EXHANGER - ASSEMBLY	1
2	4013637	COP-HEAT EXCHANGER CANAM MAVERICK X3 TURBO RR	1
3	4018524	DRP-FOAM EPDM 20×25MM LENGTH 295MM	4
4	4018525	DRP-FOAM EPDM 20×25MM LENGTH 60MM	4

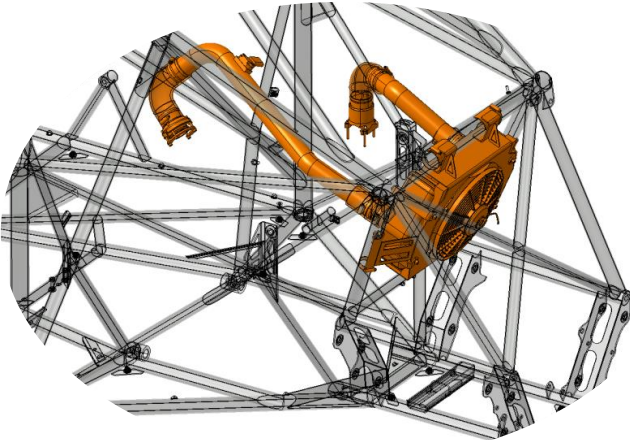
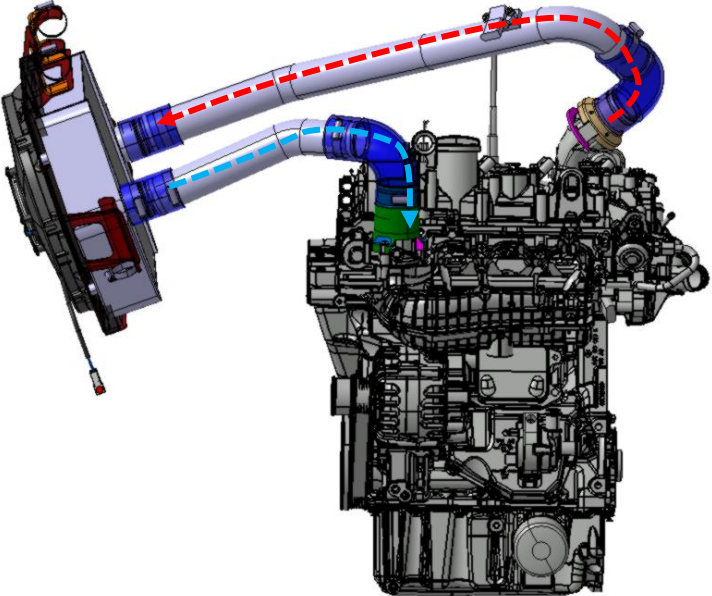
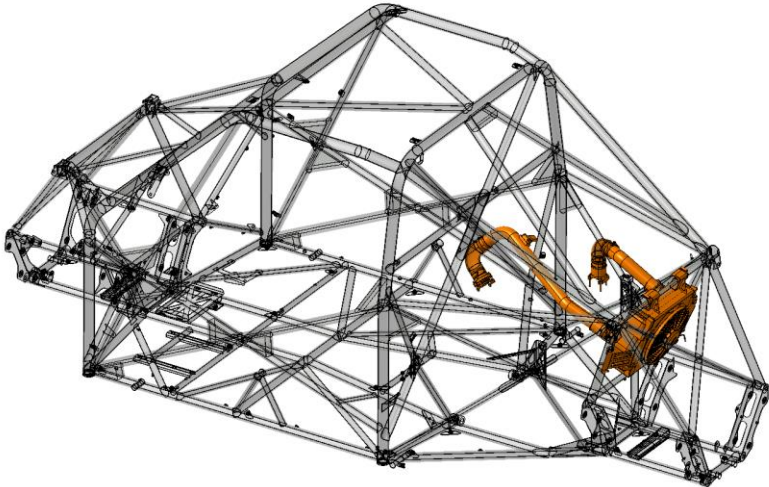
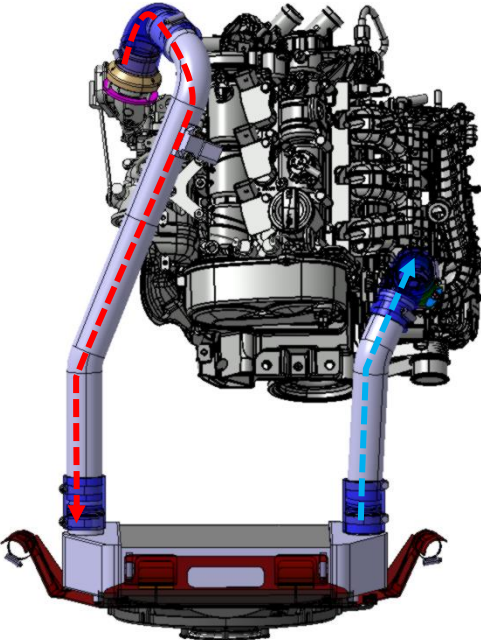

# 6.5.5 COOLING – Air /Air – Fixing to chassis

**Custom intercooler**

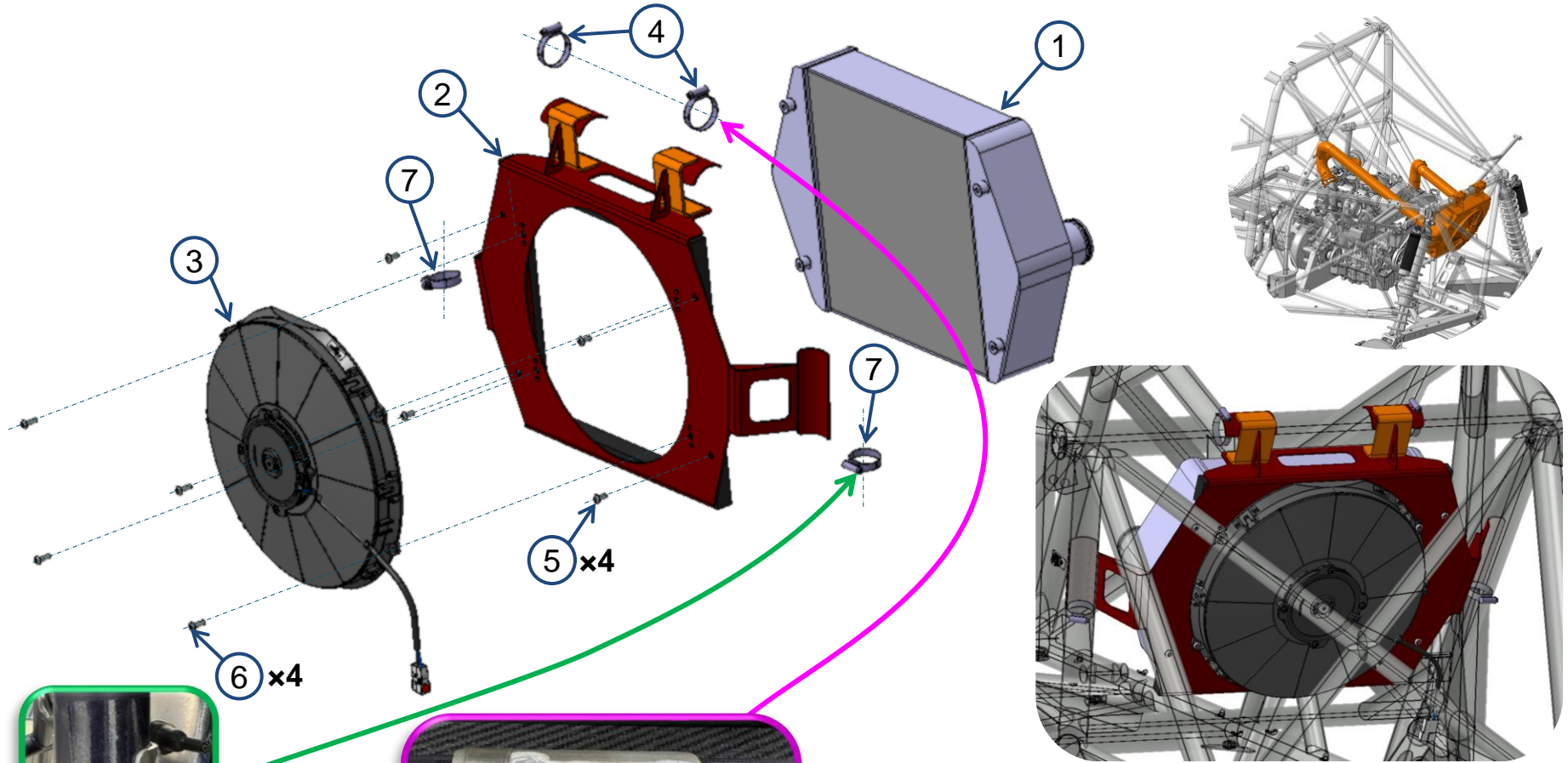

No.	Ref.	Name	Qty.
1	4019932	DRP-COOLING INTERCOOLER PWR CUSTOM	1
2	4019547	SASS-BRACKET EQUIPED – AIR/AIR INTERCOOLER CUSTOM	1
3	4020138	DRP-WIRING FAN	1
4	4021800	COP-HOSE CLAMP	2
5	4008191	SUP-BUTTON HEAD SCREW	4
6	4008192	SUP-BUTTON HEAD SCREW	4
7	4021854	COP – HOSE CLAMP	2

## 6.5.6 COOLING – Air / Air – Foam installation

### Custom intercooler

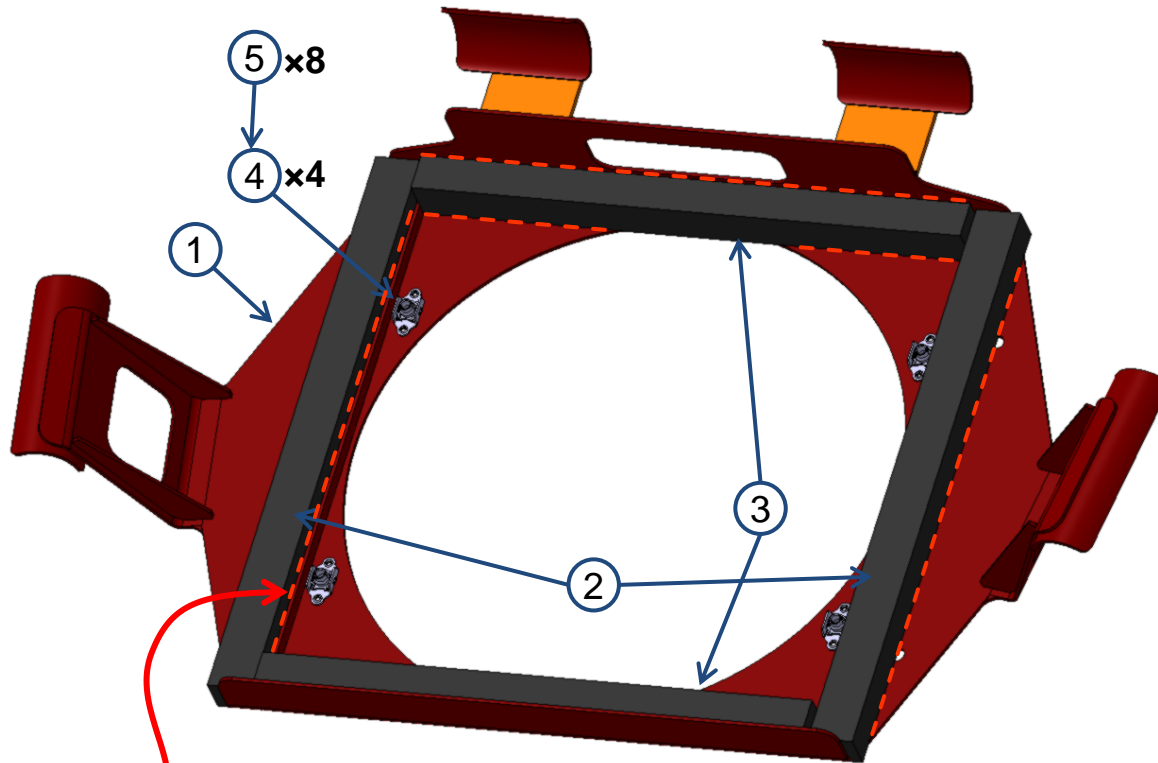

**Glue the foam and make a seal along the dotted lines on both sides.  
Foam must be well glued, so it doesn't move when the fan is on.**

**Foam may be recut if needed to allow better air flow and hardware fitting.**

No.	Ref.	Name	Qty.
1	4019535	SASS-BRACKET INTERCOOLER AIR / AIR – WELDED	1
2	4019559	DRP-FOAM EPDM 20×25MM LENGTH 330MM	2
3	4019558	DRP-FOAM EPDM 20×25MM LENGTH 310MM	2
4	4013820	COP-NUT FLOATING NUT	4
5	4016996	COP-RIVET	8

## 6.5.7 COOLING – Air / Air – Warm circuit

### All intercoolers



AIR Cooling circuit **WARM**

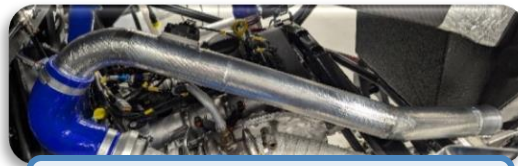

Wrap the pipe with Insulating Tape

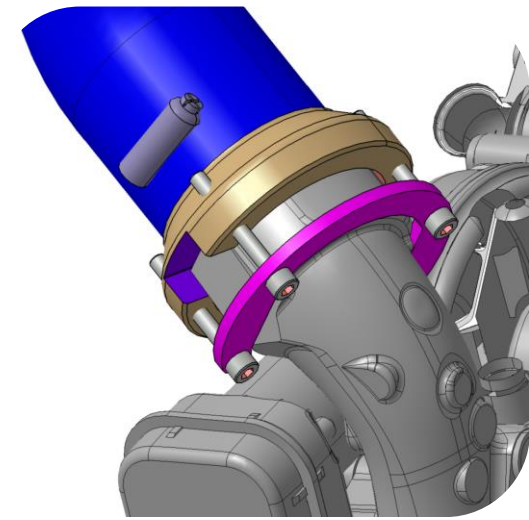
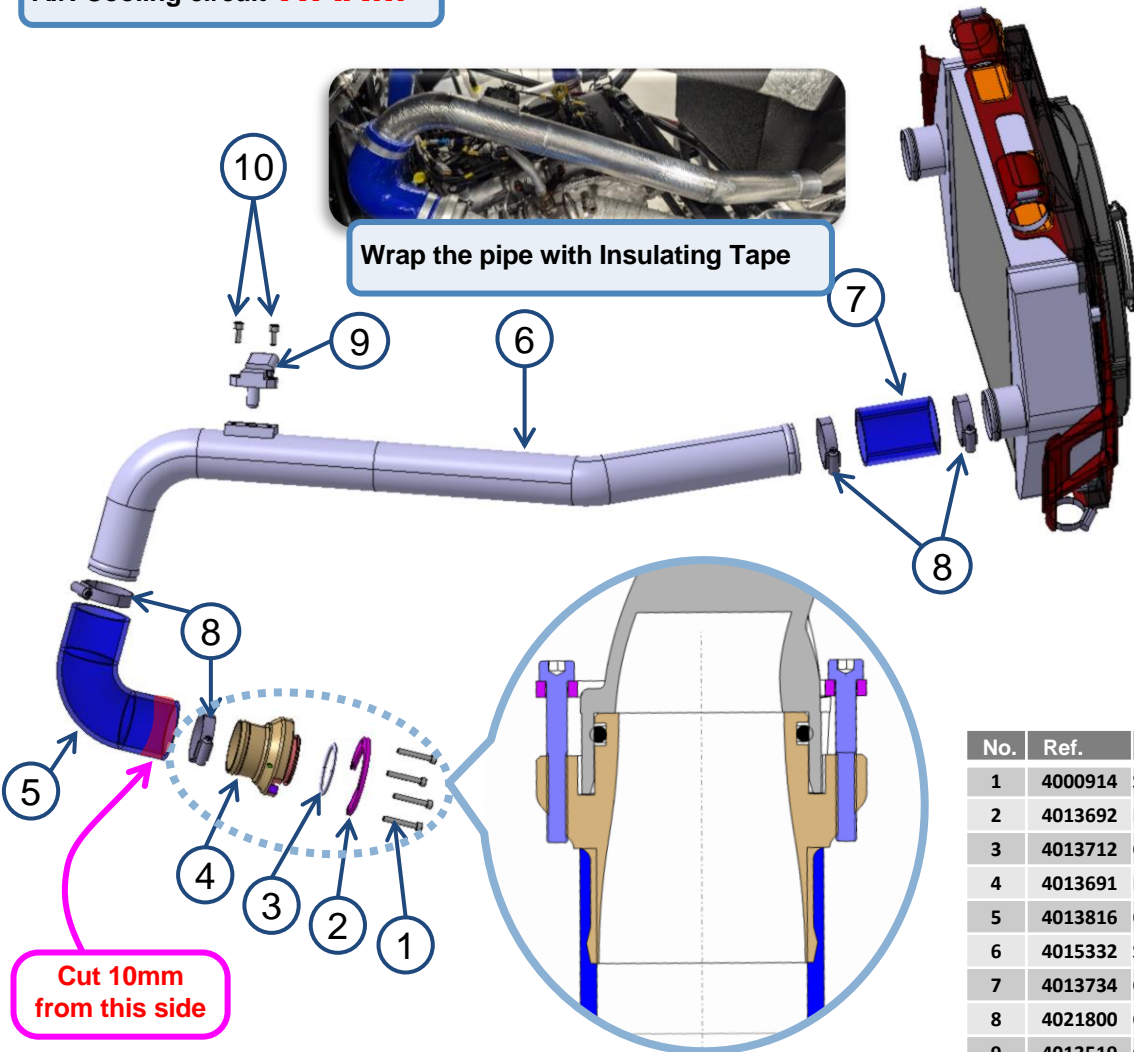

No.	Ref.	Name	Qty.
1	4000914	SUP-HEXAGONAL SOCKET CAP SCREW ISO 4762 M5X35-22 P80 CL12.9 A B	4
2	4013692	DRP-FLANGE ADAPTER TURBOCHARGER TO PIPE AIR CANAM	1
3	4013712	COP-O-RING 46X4	1
4	4013691	DRP-ADAPTER TURBOCHARGER TO PIPE AIR CANAM	1
5	4013816	COP-HOSE SILICON ØINT 51 - ELBOW 90°	1
6	4015332	SASS-COMPONENT BOOST PIPE WELDED	1
7	4013734	COP-HOSE SILICON -Ø51 – STRAIGHT L75MM	1
8	4021800	COP-HOSE CLAMP	4
9	4013519	COP-SENSOR TEMPERATURE & PRESSURE	1
10	4000585	SUP-HEXAGONAL SOCKET CAP SCREW	2

## 6.5.8 COOLING – Air / Air – Cold circuit

### All intercoolers

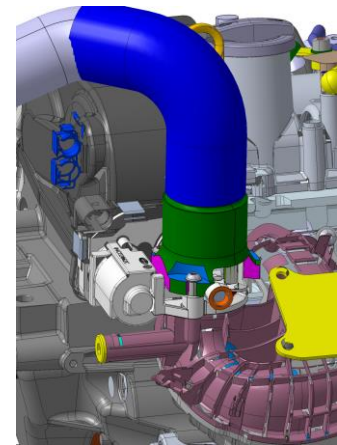

#### AIR Cooling circuit **COLD**



Wrap the pipe with Insulating Tape

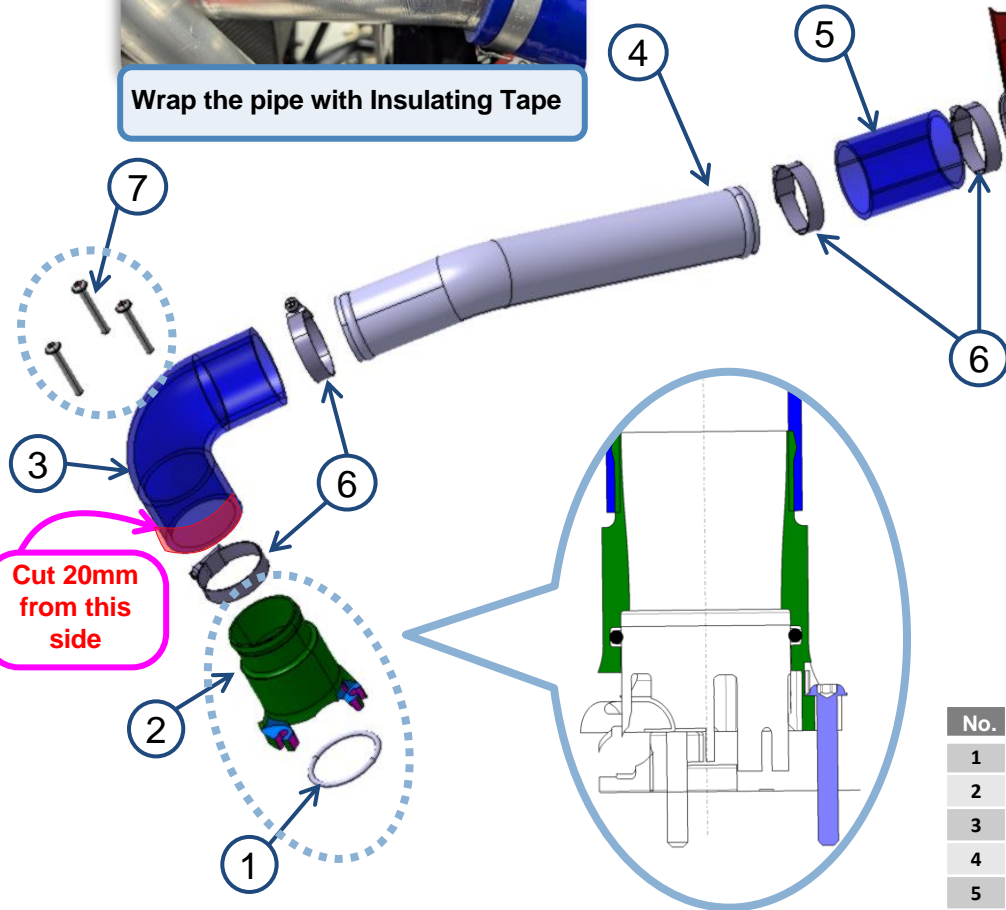

No.	Ref.	Name	Qty.
1	4013745	COP-O-RING 50X4	1
2	4013696	DRP-ADAPTER PIPE AIR TO INTAKE THROTTLE CANAM	1
3	4013816	COP-HOSE SILICON ØINT 51 - ELBOW 90°	1
4	4015335	SASS-COMPONENT CHARGE PIPE WELDED	1
5	4013734	COP-HOSE SILICON -Ø51 - STRAIGHT L75MM	1
6	4021800	COP-HOSE CLAMP WURTZ 14,3MM 40-60 MM	4
7	4013817	COP-SCREW THERMOPLASTIQUE Ø6.1X45	3

## Section 7

### INTAKE LINE



## 7.1 INTAKE LINE – Turbo Charger – Plugs

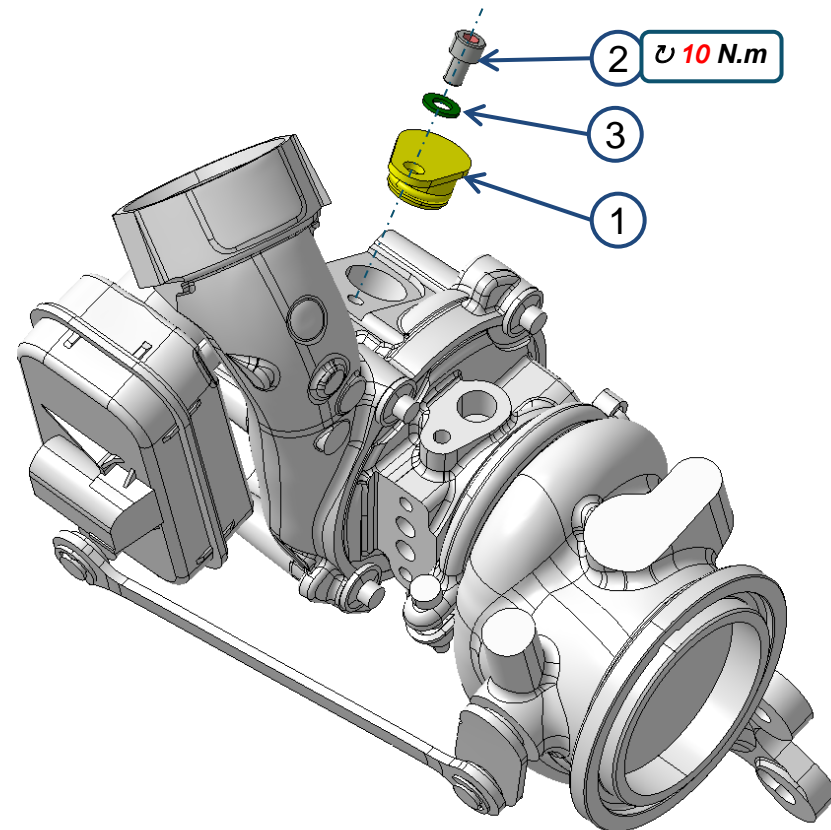

No.	Ref.	Name	Qty.
1	4013356	DRP-COMPONENT PLUG BLOW BY ON TURBO CHARGER	1
2	4000931	SUP-HEXAGONAL SOCKET CAP SCREW ISO 4762 M6X10-10 P100 CL12.9 A B	1
3	4009150	SUP-PLAIN WASHER D6XD12X1.2 TYPE Z NFE25-514 A EZ	1

## 7.3 INTAKE LINE – Turbo Charger – FIA Restrictor

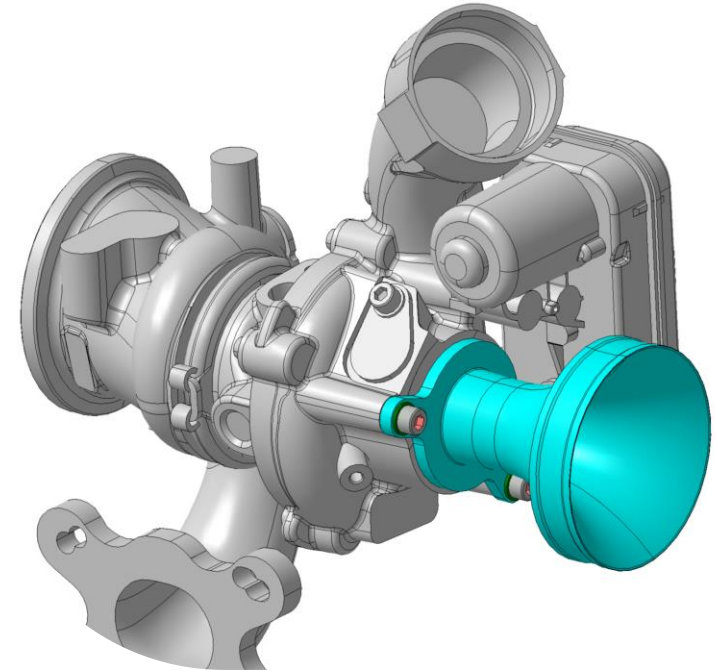
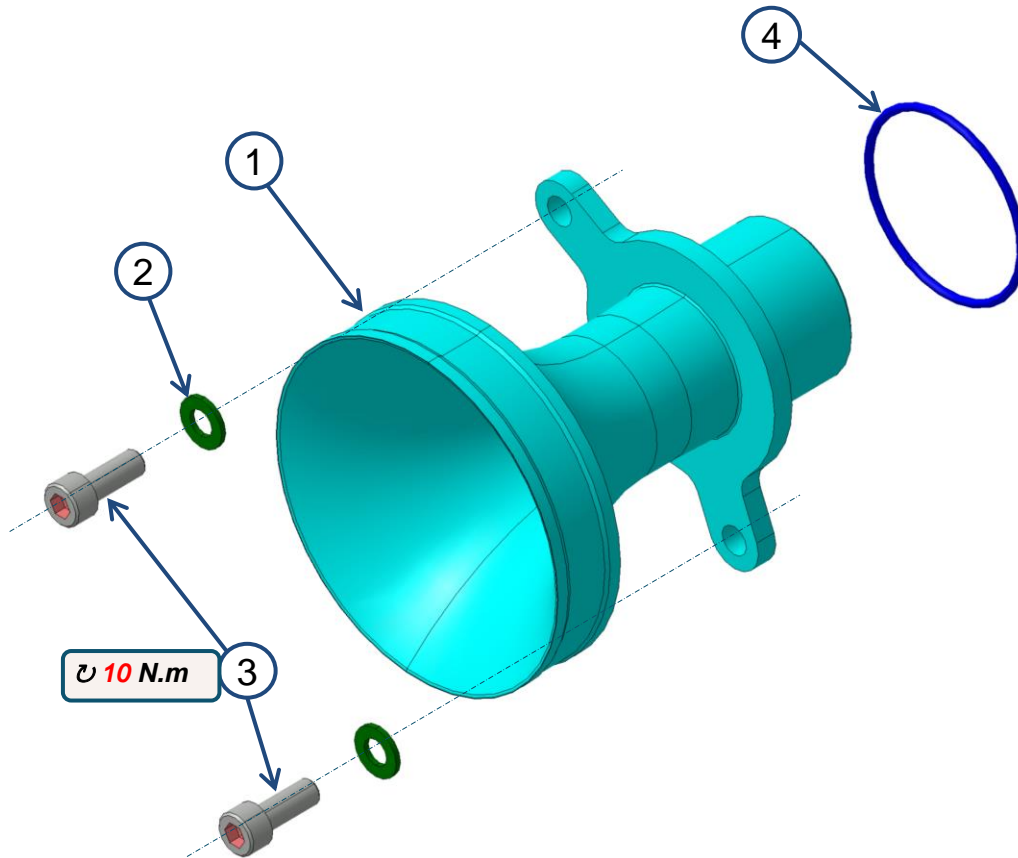

Assembly tips ???

No.	Ref.	Name	Qty.
1	4013450	DRP-RESTRICTOR AIR INTAKE Ø27 NON-INSTRUMENTED	1
2	4009150	SUP-PLAIN WASHER D6XD12X1.2 TYPE Z NFE25-514 A EZ	2
3	4000934	SUP-HEXAGONAL SOCKET CAP SCREW ISO 4762 M6X16-16 P100 CL12.9 A B	2
4	4014667	SUP-O-RING ID 42-TORE 2 - FKM 70 SHORE A	1

# 7.5 INTAKE LINE – TURBO CHARGER – Fixing to motor

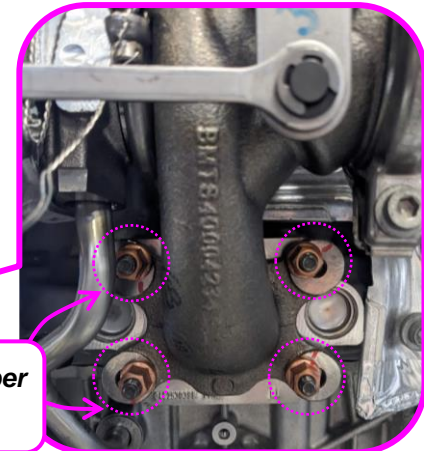
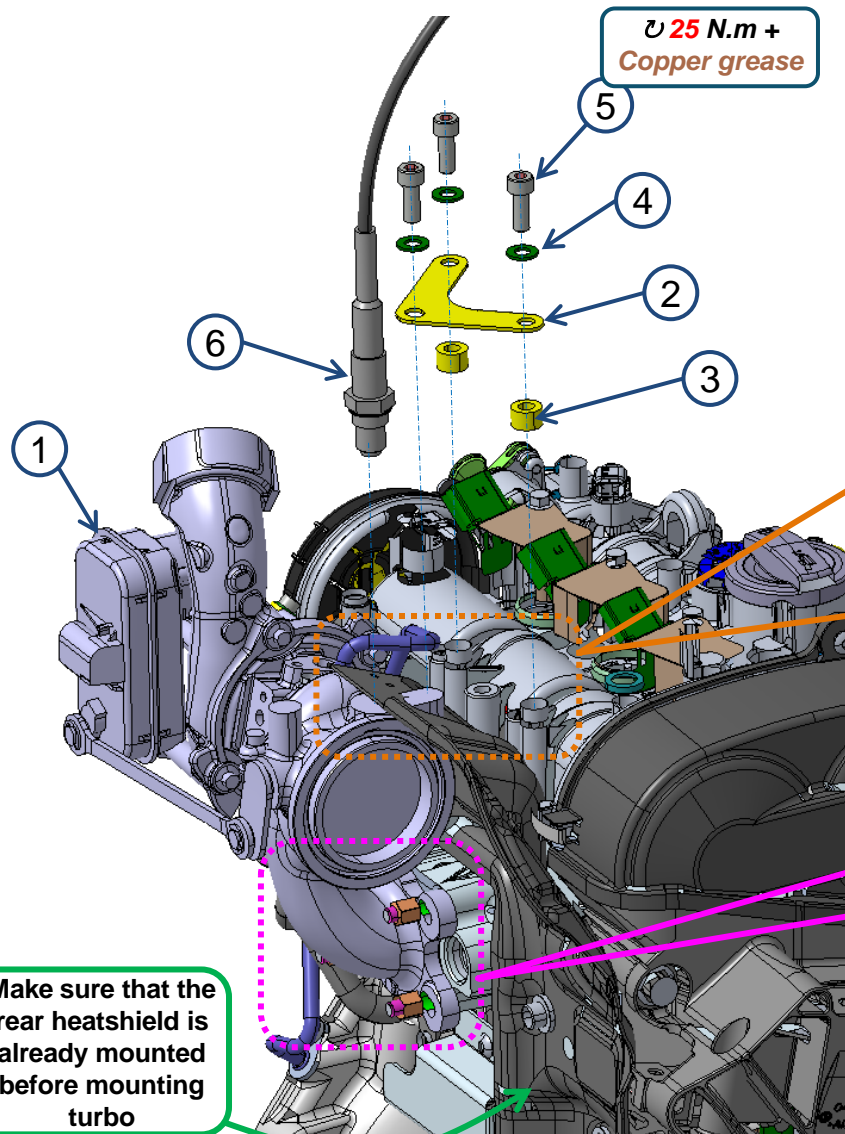

No.	Ref.	Number-Version-Name	Qty.
1	4013453	DRP-TURBOCHARGER VW REWORKED	1
2	4014150	DRP-COMPONENT BRACKET TURBO	1
3	4014662	DRP-SPACER	2
4	4009151	SUP-PLAIN WASHER	3
5	4000964	SUP-HEXAGONAL SOCKET CAP SCREW	3
6	4012689	COP-SENSOR LAMBDA	1

# 7.6 INTAKE– Turbocharger – Heatshield

Locknut / Floating nut is inside the airbox

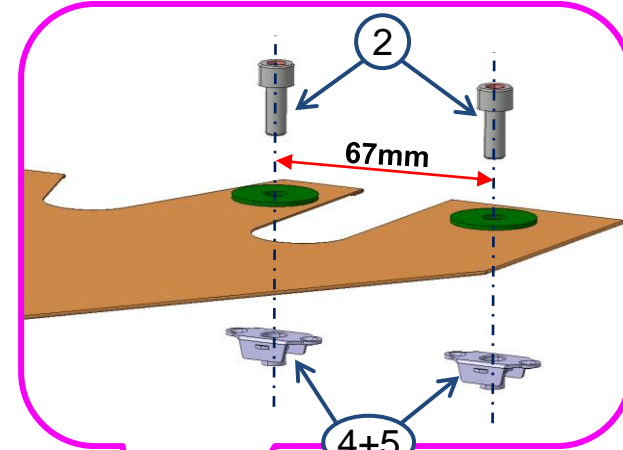
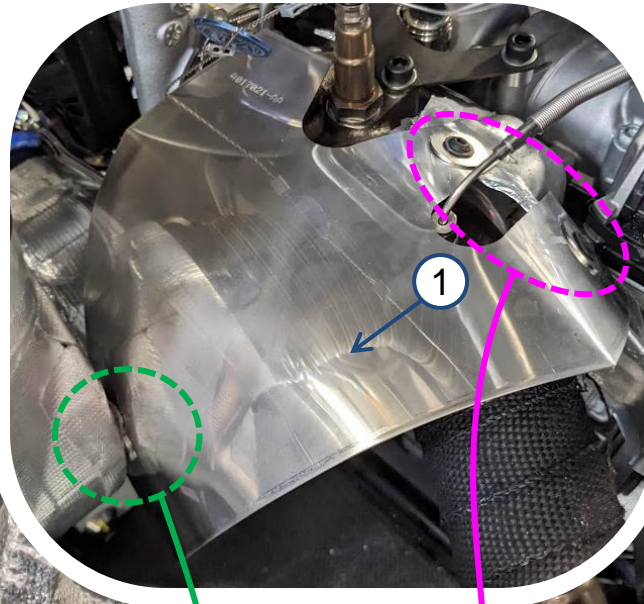
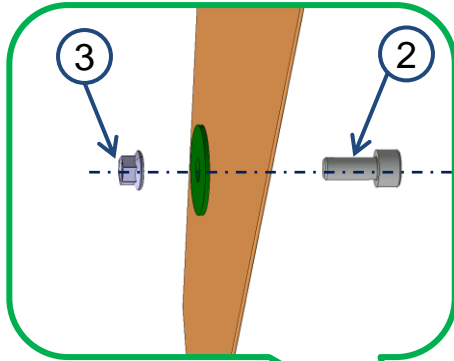

Floating nuts fixed on motor heatshield with rivets

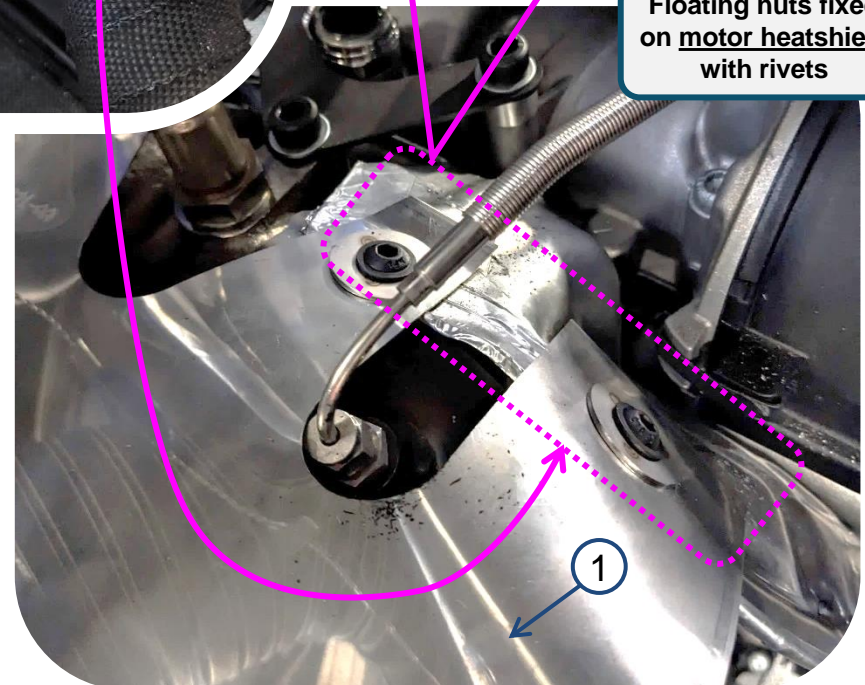
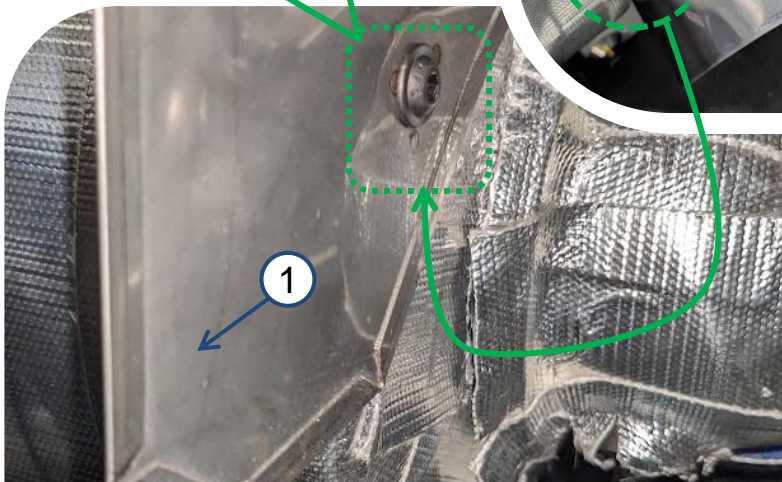

No.	Ref.	Number-Version-Name	Qty.
1	4017021	SASS-HEAT SHIELD TURBOCHARGER WELDED	1
2	4000933	SUP-HEXAGONAL SOCKET CAP SCREW	3
3	4013685	SUP-LOCKNUT WITH FLANGE	1
4	4013820	COP-NUT FLOATING NUT M6	2
5	4016996	COP-RIVET	4

## 7.7.1 INTAKE LINE – Air cartridge

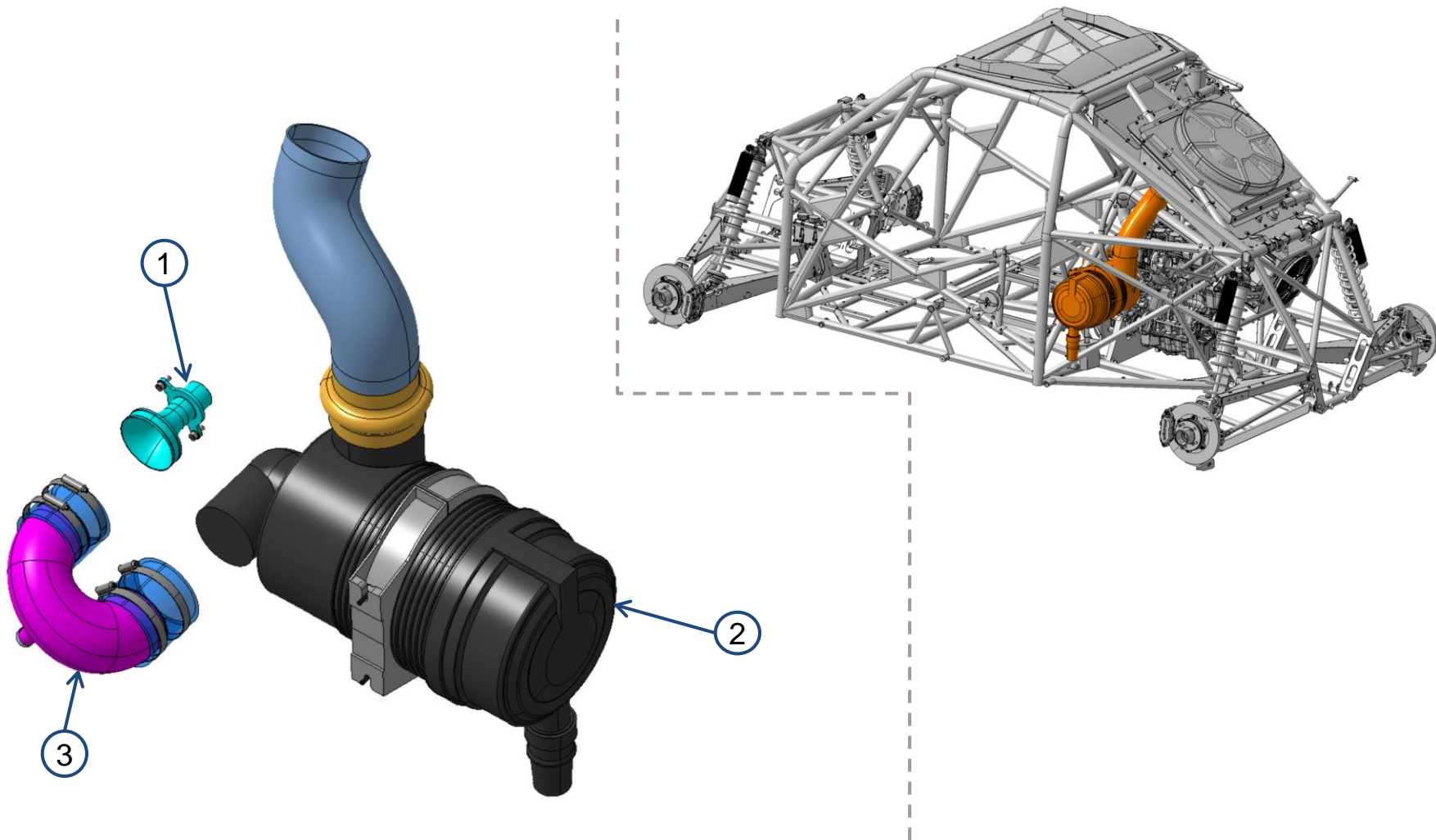

No.	Ref.	Name	Qty.
1	4014664	SASS - RESTRICTOR AIR INTAKE Ø27 NON INSTRUMENTED	1
2	4014510	SASS - COMPONENT AIR FILTER COMPLETE	1
3	4014511	SASS - COMPONENT INTAKE PIPE	1

## 7.7.2 INTAKE LINE - Air Filter

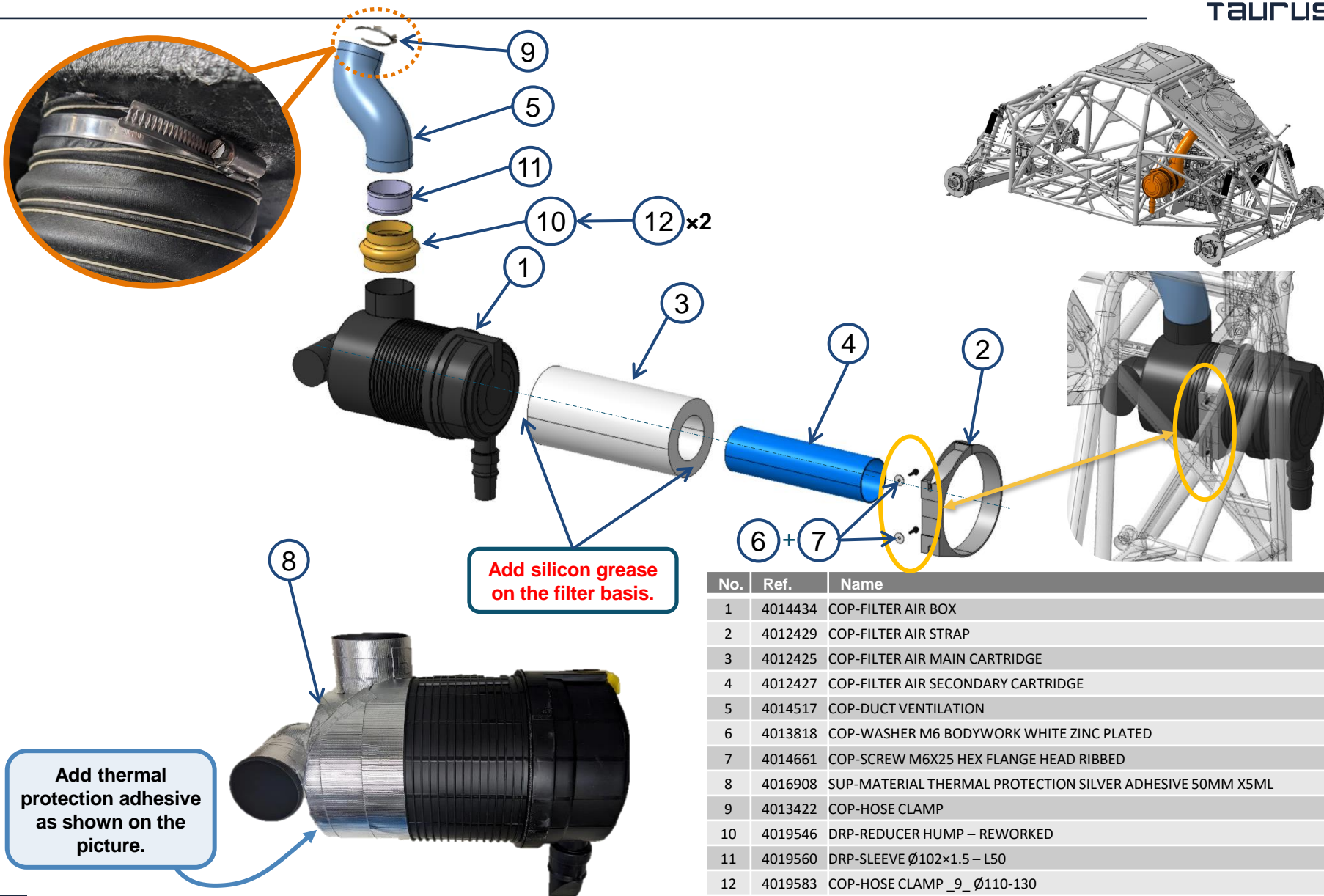

No.	Ref.	Name	Qty.
1	4014434	COP-FILTER AIR BOX	1
2	4012429	COP-FILTER AIR STRAP	1
3	4012425	COP-FILTER AIR MAIN CARTRIDGE	1
4	4012427	COP-FILTER AIR SECONDARY CARTRIDGE	1
5	4014517	COP-DUCT VENTILATION	1
6	4013818	COP-WASHER M6 BODYWORK WHITE ZINC PLATED	2
7	4014661	COP-SCREW M6X25 HEX FLANGE HEAD RIBBED	2
8	4016908	SUP-MATERIAL THERMAL PROTECTION SILVER ADHESIVE 50MM X5ML	1
9	4013422	COP-HOSE CLAMP	1
10	4019546	DRP-REDUCER HUMP – REWORKED	1
11	4019560	DRP-SLEEVE Ø102×1.5 – L50	1
12	4019583	COP-HOSE CLAMP _9_ Ø110-130	2

## 7.8 INTAKE LINE - Intake Pipe

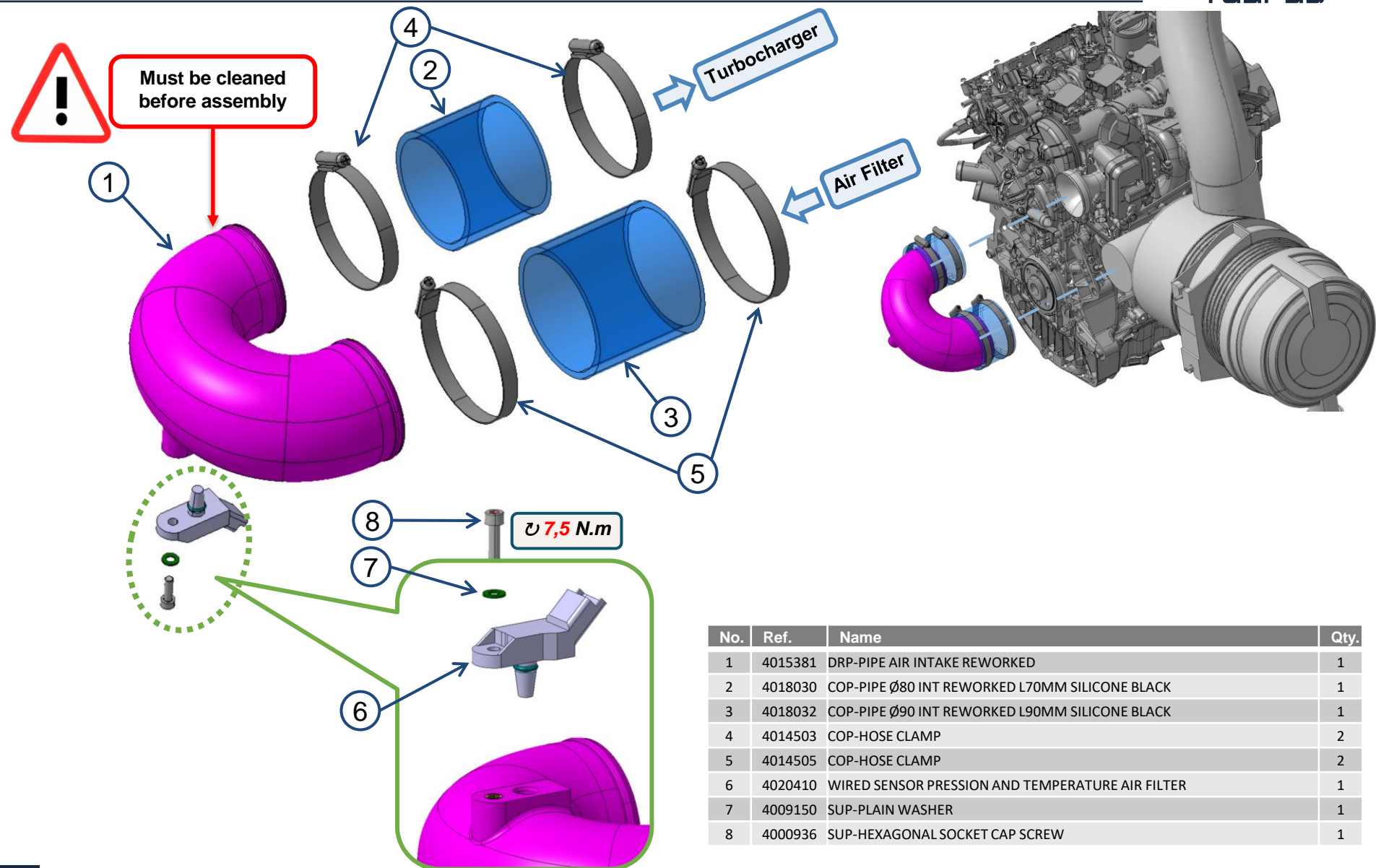

## Section 8

### FRONT & REAR DRIVE



## 8 – TOOL NEEDED :

### ■ Specific tool needed

- ▶ **4018513 – Rose joint tool**

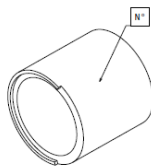

- ▶ **4018514 – Rose joint tool**

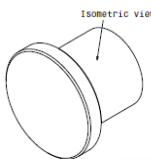

- ▶ **4018044 – Rose Joint removal tool**



- ▶ **Torque wrench : 40 → 200 Nm**

### ■ Specific sealing needed:

- ▶ **Loctite 271**
- ▶ **Loctite 648**
- ▶ **Copper grease**

#### Assembly tips:

- Put the rose joints at **-18°C** during 2 hours

# 8.1 FRONT AND REAR DRIVE – Overview

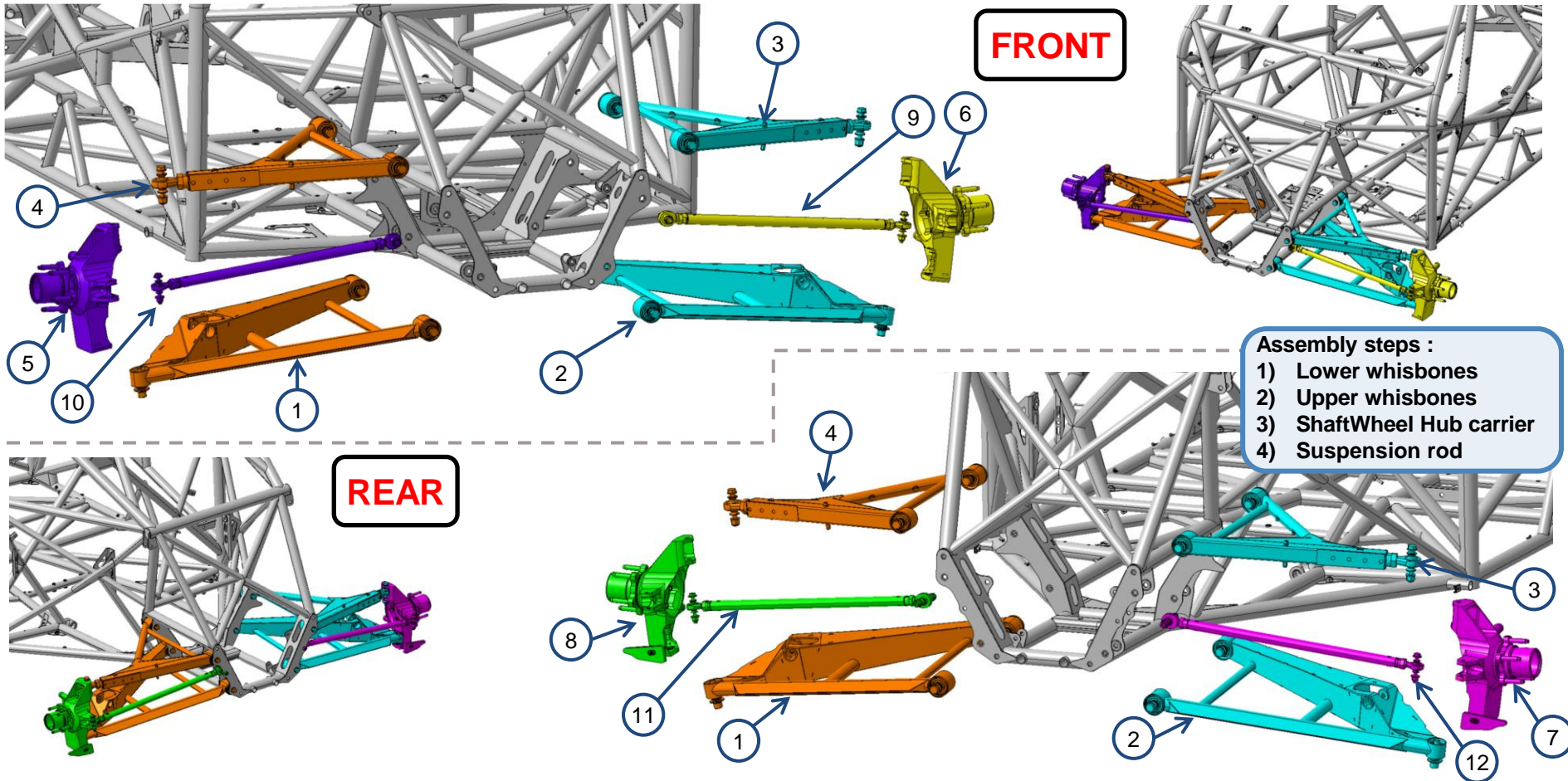

No.	Ref.	Name	Qty.	No.	Ref.	Number-Version-Name	Qty.
1	4012646	SASS-COMPONENT LOWER WISHBONE EQUIPPED FR/RL	2	7	4012634	ASS-ASSEMBLY WHEEL HUB CARRIER RR	1
2	4012648	SASS-COMPONENT LOWER WISHBONE EQUIPPED FL/RR	2	8	4012632	ASS-ASSEMBLY WHEEL HUB CARRIER RL	1
3	4012948	SASS-COMPONENT UPPER WISHBONE EQUIPPED FL/RR	2	9	4012710	SASS-COMPONENT FRONT LEFT SUSPENSION ROD EQUIPPED	1
4	4012949	SASS-COMPONENT UPPER WISHBONE EQUIPPED FR/RL	2	10	4012733	SASS-COMPONENT FRONT RIGHT SUSPENSION ROD EQUIPPED	1
5	4016984	ASS-ASSEMBLY WHEEL HUB CARRIER FR	1	11	4012721	SASS-COMPONENT REAR LEFT SUSPENSION ROD EQUIPPED	1
6	4016985	ASS-ASSEMBLY WHEEL HUB CARRIER FL	1	12	4012732	SASS-COMPONENT REAR RIGHT SUSPENSION ROD EQUIPPED	1

## 8.2 Wishbone protocol assembly - Upper / lower - Front / Rear

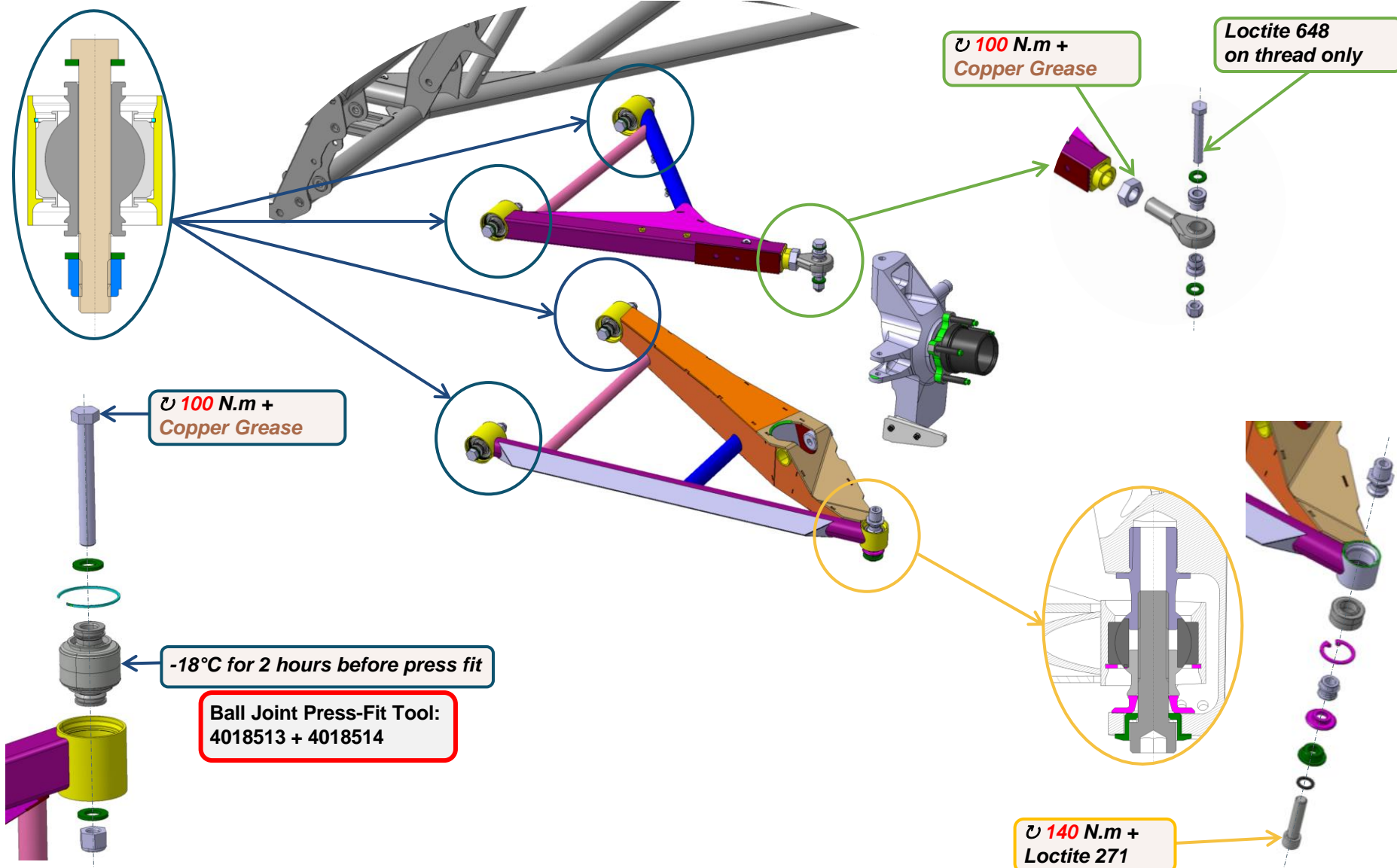

## 8.3.1 Lower wishbone – Front right, Rear Left.

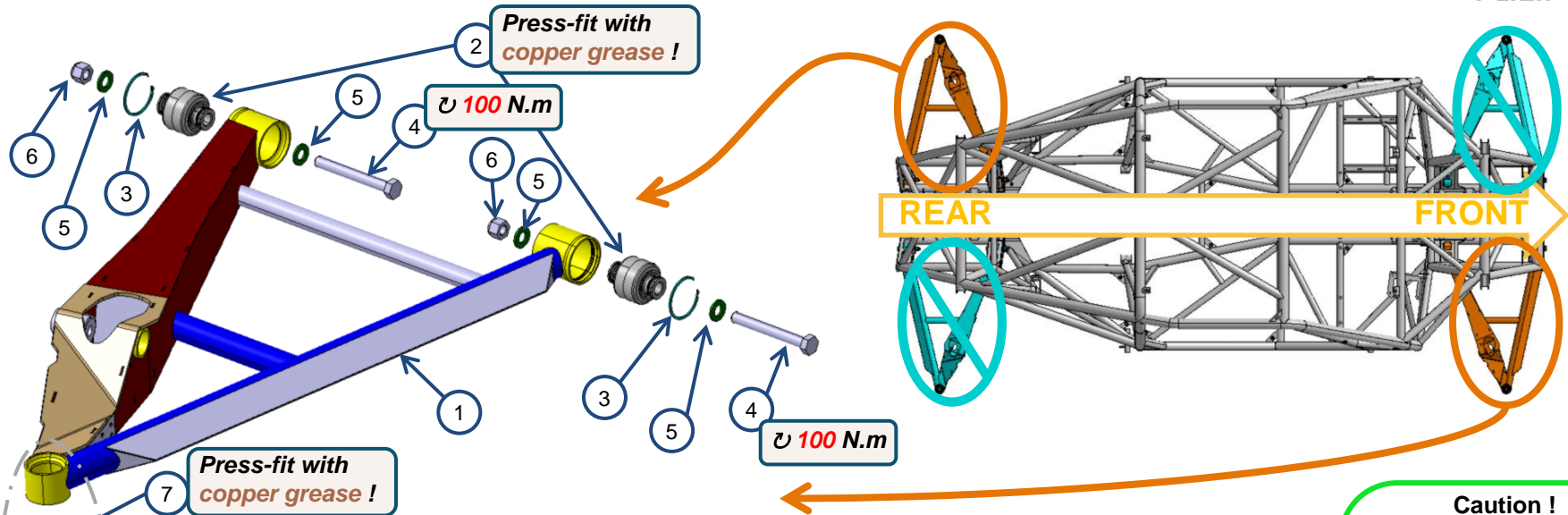

Press-fit with copper grease !

Press-fit with copper grease !

100 N.m

100 N.m

140 N.m + Loctite 290

These components are part of the wheel hub sub assembly

### Press-Fit Tooling protocol :

- Put the rose joints at -18°C during 2 hours

**Caution !**  
On previous chassis versions, screw 4016868 must be 103mm

This reinforcing metal sheet is present on previous chassis versions

No.	Ref.	Name	Qty.
1	4012516	SASS-COMPONENT LOWER WISHBONE RIGHT	1
2	4016538	COP-BALL JOINT STEERING TRIANGLE	2
3	4014289	DRP-CIRCLIP REWORKED	2
4	4016868	DRP-SCREW REWORKED L96MM	2
5	4009153	SUP-PLAIN WASHER	4
6	4012441	COP-NUT	2
7	4012445	COP-BALL JOINT	1
8	4012438	COP-CLIP	1
9	4001057	SUP-HEXAGONAL SOCKET CAP SCREW	1
10	4012658	DRP-SPACER LARGE ANGLE LOWER	1
11	4012659	DRP-WASHER	1
12	4014391	COP-WASHER SCHNORR	1

## 8.3.2 Lower wishbone – Front Left, Rear Right.

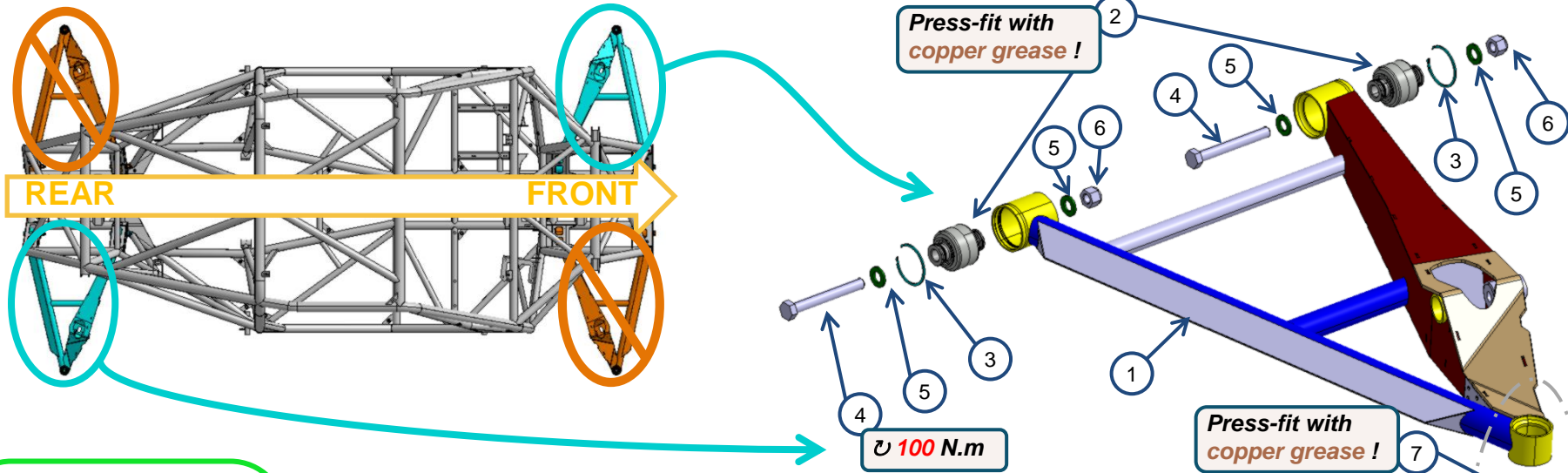

**Caution !**  
On previous chassis versions, screw 4016868 must be 103mm

This reinforcing metal sheet is present on previous chassis versions

**Press-Fit Tooling protocol :**  
• Put the rose joints at **-18°C** during 2 hours

No.	Ref.	Name	Qty.
1	4012536	SASS-COMPONENT LOWER WISHBONE LEFT	1
2	4016538	COP-BALL JOINT STEERING TRIANGLE	2
3	4014289	DRP-CIRCLIP REWORKED	2
4	4016868	DRP-SCREW REWORKED L96MM	2
5	4009153	SUP-PLAIN WASHER	4
6	4012441	COP-NUT	2
7	4012445	COP-BALL JOINT	1
8	4012438	COP-CLIP	1
9	4001057	SUP-HEXAGONAL SOCKET CAP SCREW	1
10	4012658	DRP-SPACER LARGE ANGLE LOWER	1
11	4012659	DRP-WASHER	1
12	4014391	COP-WASHER SCHNORR	1

# 8.4 UPPER WISHBONE – Left & Right, Front & Rear

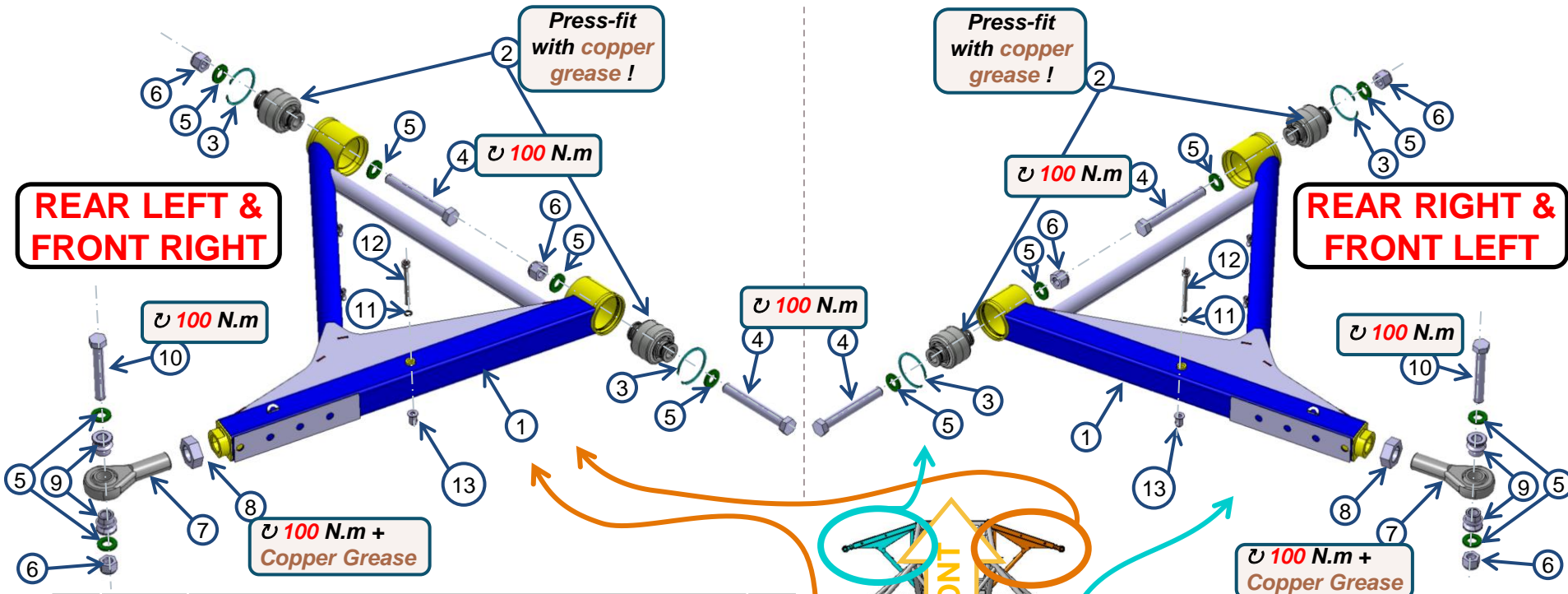

No.	Ref.	Name	Qty.
1	4012945	SASS-COMPONENT UPPER WISHBONE	1
2	4016538	COP-BALL JOINT STEERING TRIANGLE	2
3	4014289	DRP-CIRCLIP D47 INTERIOR REWORKED	2
4	4016868	DRP-SCREW TH REWORKED	2
5	4009153	SUP-PLAIN WASHER	6
6	4012441	COP-NUT	3
7	4012446	COP-BALL JOINT	1
8	4012485	SUP-JAM NUT	1
9	4012456	COP-SPACER WIDE ANGLE	2
10	4016869	DRP-SCREW TH REWORKED	1
11	4014024	COP-WASHER SCHNORR	1
12	4000945	SUP-HEXAGONAL SOCKET CAP SCREW	1
13	401826	COP-INSERT TAPPED M6	1

**Caution !**  
On previous chassis versions, screw 4016868 must be 103mm

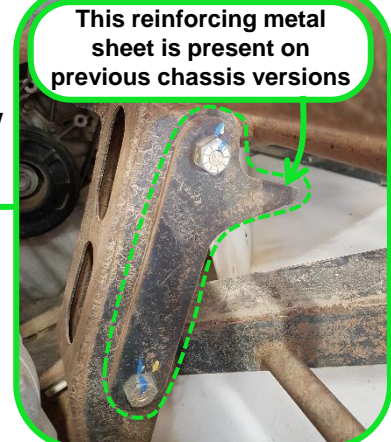

# 8.5.1 FRONT DRIVE - ASSEMBLY WHEEL HUB CARRIER RIGHT + LEFT

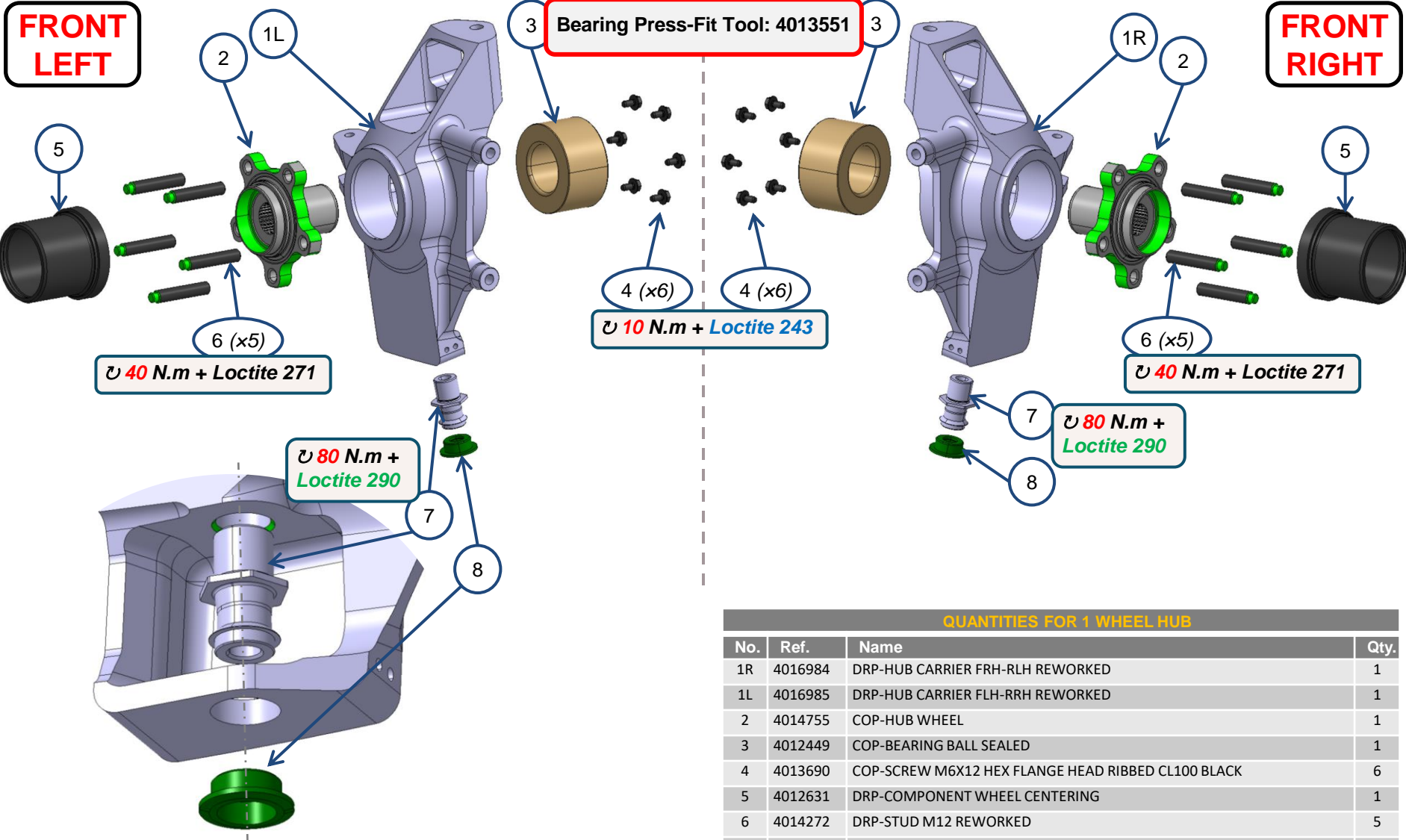

QUANTITIES FOR 1 WHEEL HUB				
No.	Ref.	Name		Qty.
1R	4016984	DRP-HUB CARRIER FRH-RLH REWORKED		1
1L	4016985	DRP-HUB CARRIER FLH-RRH REWORKED		1
2	4014755	COP-HUB WHEEL		1
3	4012449	COP-BEARING BALL SEALED		1
4	4013690	COP-SCREW M6X12 HEX FLANGE HEAD RIBBED CL100 BLACK		6
5	4012631	DRP-COMPONENT WHEEL CENTERING		1
6	4014272	DRP-STUD M12 REWORKED		5
7	4012657	DRP-SPACER LARGE ANGLE UPPER CAP		1
8	4012734	DRP-COMPONENT SOCKET		1

## 8.5.2 REAR DRIVE - ASSEMBLY WHEEL HUB CARRIER RIGHT + LEFT

**REAR LEFT**

**REAR RIGHT**

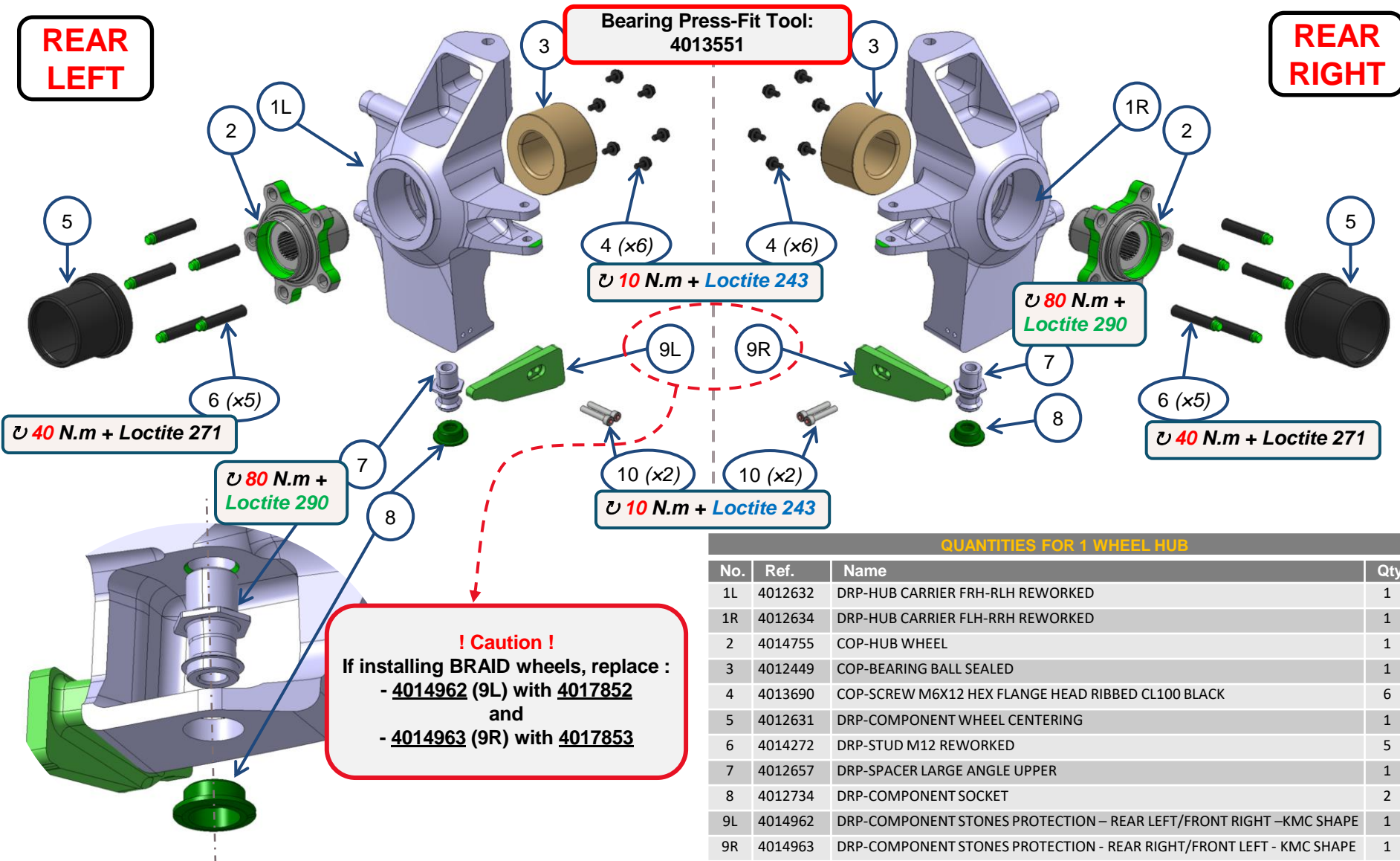

### QUANTITIES FOR 1 WHEEL HUB

No.	Ref.	Name	Qty.
1L	4012632	DRP-HUB CARRIER FRH-RLH REWORKED	1
1R	4012634	DRP-HUB CARRIER FLH-RRH REWORKED	1
2	4014755	COP-HUB WHEEL	1
3	4012449	COP-BEARING BALL SEALED	1
4	4013690	COP-SCREW M6X12 HEX FLANGE HEAD RIBBED CL100 BLACK	6
5	4012631	DRP-COMPONENT WHEEL CENTERING	1
6	4014272	DRP-STUD M12 REWORKED	5
7	4012657	DRP-SPACER LARGE ANGLE UPPER	1
8	4012734	DRP-COMPONENT SOCKET	2
9L	4014962	DRP-COMPONENT STONES PROTECTION - REAR LEFT/FRONT RIGHT -KMC SHAPE	1
9R	4014963	DRP-COMPONENT STONES PROTECTION - REAR RIGHT/FRONT LEFT - KMC SHAPE	1
10	4000940	SUP-HEXAGONAL SOCKET CAP SCREW	1



# 8.6.1 Front Drive – FRONT ROD EQUIPPED RIGHT

Right and left bar are the same



**FRONT  
RIGHT**

Length: 625 mm

**FRONT  
LEFT**

Length: 625 mm

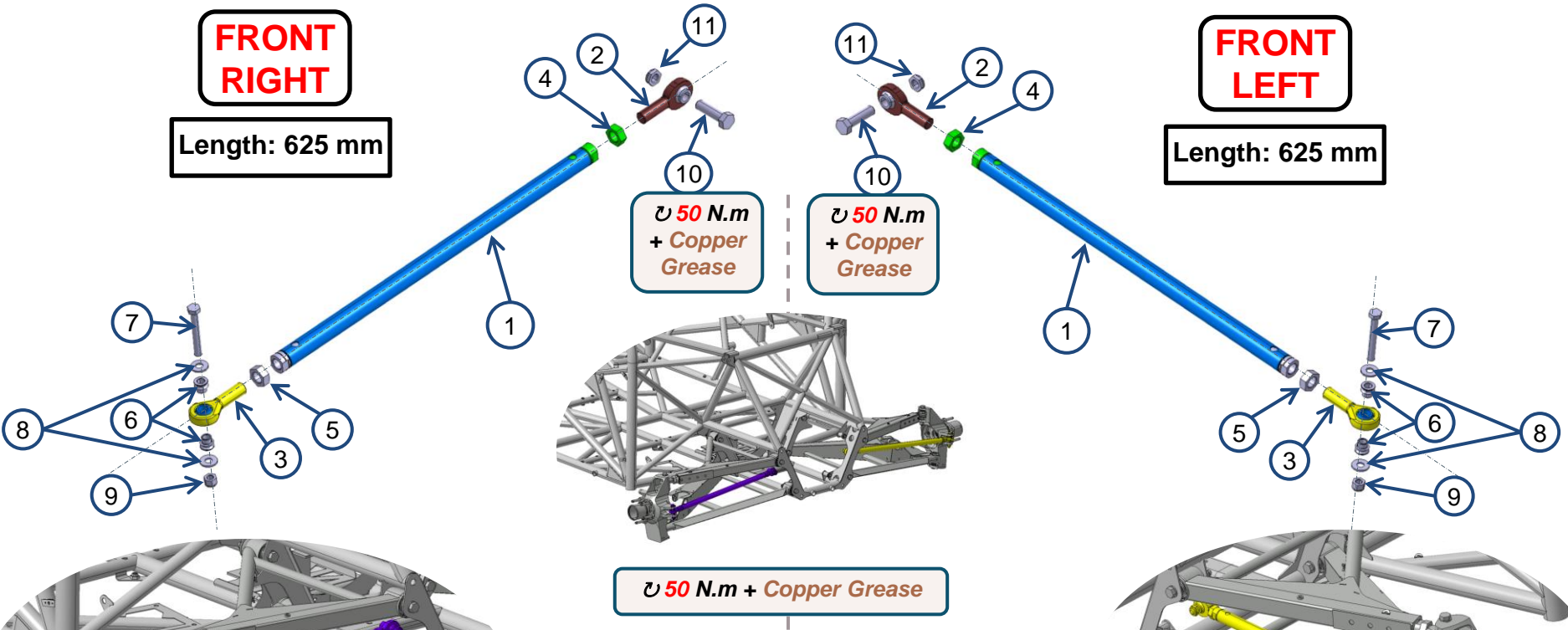

No.	Ref.	Name	Qty.
1	4012709	SASS-COMPONENT FRONT SUSPENSION ROD WELDED	1
2	4012565	COP-BALL JOINT – RIGHT	1
3	4012567	COP-BALL JOINT – LEFT	1
4	4012572	COP-NUT	1
5	4012573	COP-NUT LEFT	1
6	4012574	COP-HI-MISALIGNMENT SPACER	2
7	4012575	COP-SCREW	1
8	4012576	COP-WASHER	2
9	4012577	COP-LOCK NUT	1
10	4014998	DRP-SCREW TH REWORKED	1
11	4014996	COP-LOCK NUT HEX JAM NYLON INSERT ZINC PLATED STEEL	1

## 8.6.2 Rear Drive – REAR ROD EQUIPPED RIGHT

Right and left bar are the same



**REAR LEFT**

Length: 655 mm

**50 N.m + Copper Grease**

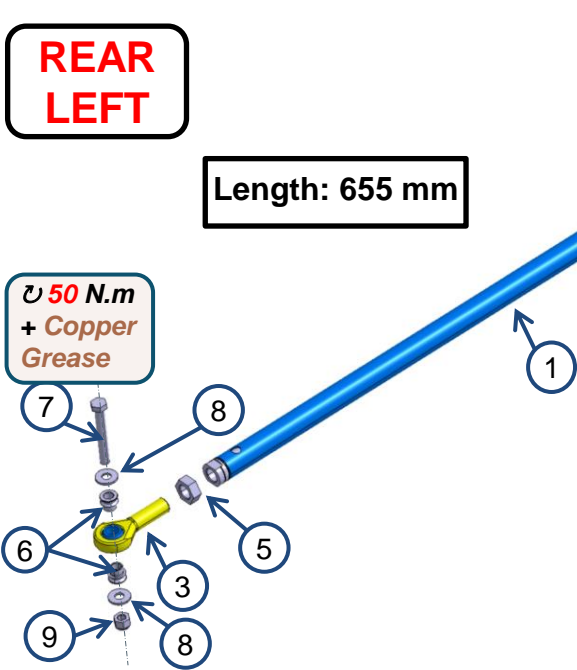

**50 N.m + Copper Grease**

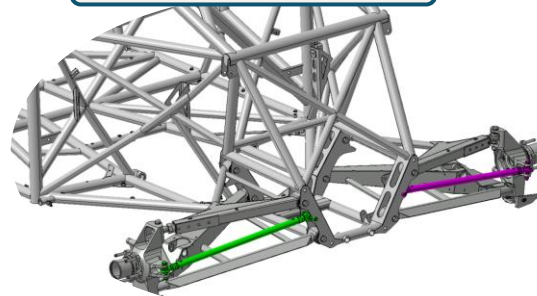

**REAR RIGHT**

Length: 655 mm

**50 N.m + Copper Grease**

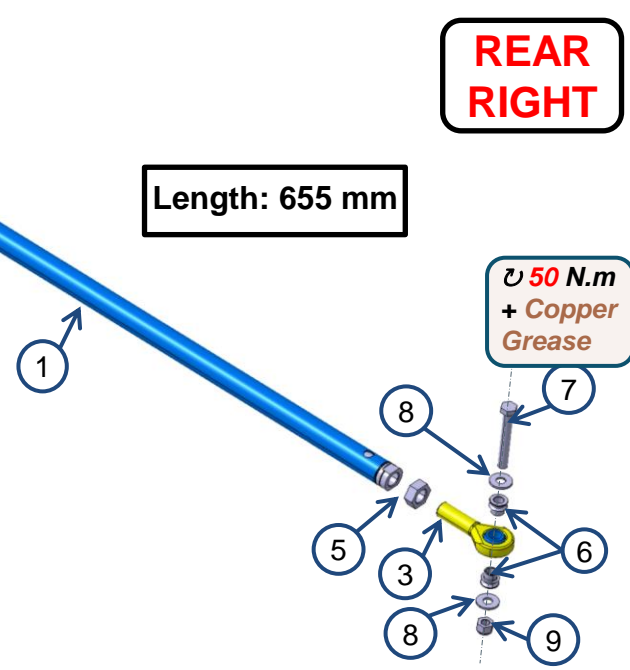

No.	Ref.	Name	Qty.
1	4012715	SASS-COMPONENT REAR SUSPENSION ROD WELDED	1
2	4012565	BALL JOINT – RIGHT	1
3	4012567	BALL JOINT – LEFT	1
4	4012572	NUT	1
5	4012573	NUT – LEFT	1
6	4012574	HI-MISALIGNMENT SPACER	2
7	4012575	SCREW	1
8	4012576	WASHER	2
9	4012577	LOCK NUT	1
10	4000654	SUP-HEXAGONAL SOCKET CAP SCREW	1
11	4012476	SUP-LOCKNUT	1
12	4012731	DRP-COMPONENT REAR SUSPENSION ROD BUSHING	2

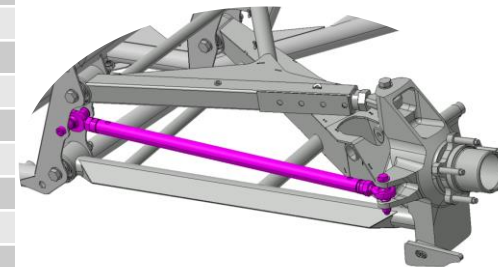
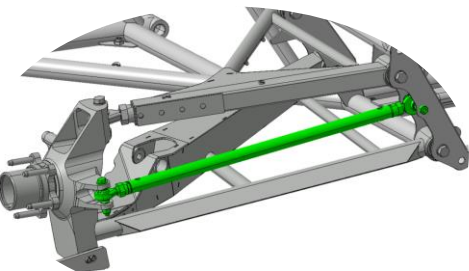

## Section 9

# SUSPENSION

- **Specific tool needed**

- **Damper clamps**

- **Specific sealing needed:**

# 9. SUSPENSION – Assembly

**REAR**

⌚ 100 N.m +  
Copper Grease

**FRONT**

⌚ 100 N.m +  
Copper Grease

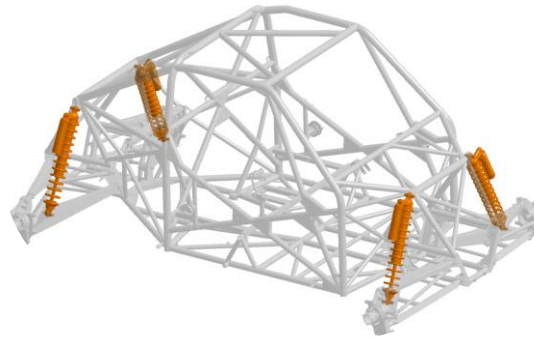

**⚠ CAUTION ⚠**  
Bottom screw is always in the middle of the triangle as shown on picture below

**Proximity to check**

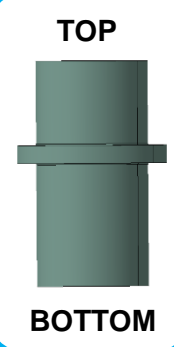
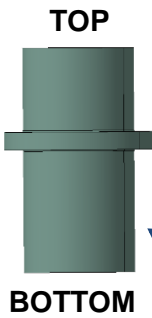

⌚ 100 N.m +  
Copper Grease

⌚ 100 N.m +  
Copper Grease

**⚠ CAUTION ⚠**  
Pay attention to the orientation of the screws and nuts.  
**REAR : Top and bottom screw heads on opposite sides**  
**FRONT : Top and bottom screw heads on the same side**

QUANTITIES FOR 1 SHOCK	No.	Ref.	Name	Qty.
	1		SASS DAMPER REIGER CUSTOM EIBACH - FRONT	2
	2		SASS DAMPER REIGER CUSTOM EIBACH - REAR	2
	3	4016941	DRP-SCREW M12 L75 REWORKED L60	8
	4	4009153	SUP-PLAIN WASHER D12XD24X2.5 TYPE Z NFE25-514 A EZ	6
	5	4014557	SUP-LOCKNUT WITH FLANGE - M12X1.75 - SIMMONDS	4
	6	4016522	COP-PLUG [A] 25.4MMx19.0MM CAPUCHON ROND VINYLE NOIR (A25.4S)	4
	7	4014964	DRP-WASHER SPRING CUP Ø76 - Ø100 - TH1	4
	8	4015040	DRP-SLEEVE SPRING TRANSITION	4

## Section 10

### Drive Train

### ■ Specific tool needed

- ▶ **Torque wrench : 40 – 400 Nm**

### ■ Specific sealing needed:

- ▶ **Loctite 270**
- ▶ **Loctite 5910 or Wurtz RTV**
- ▶ **NEO grease**

# 10.1 DRIVETRAIN – Overview

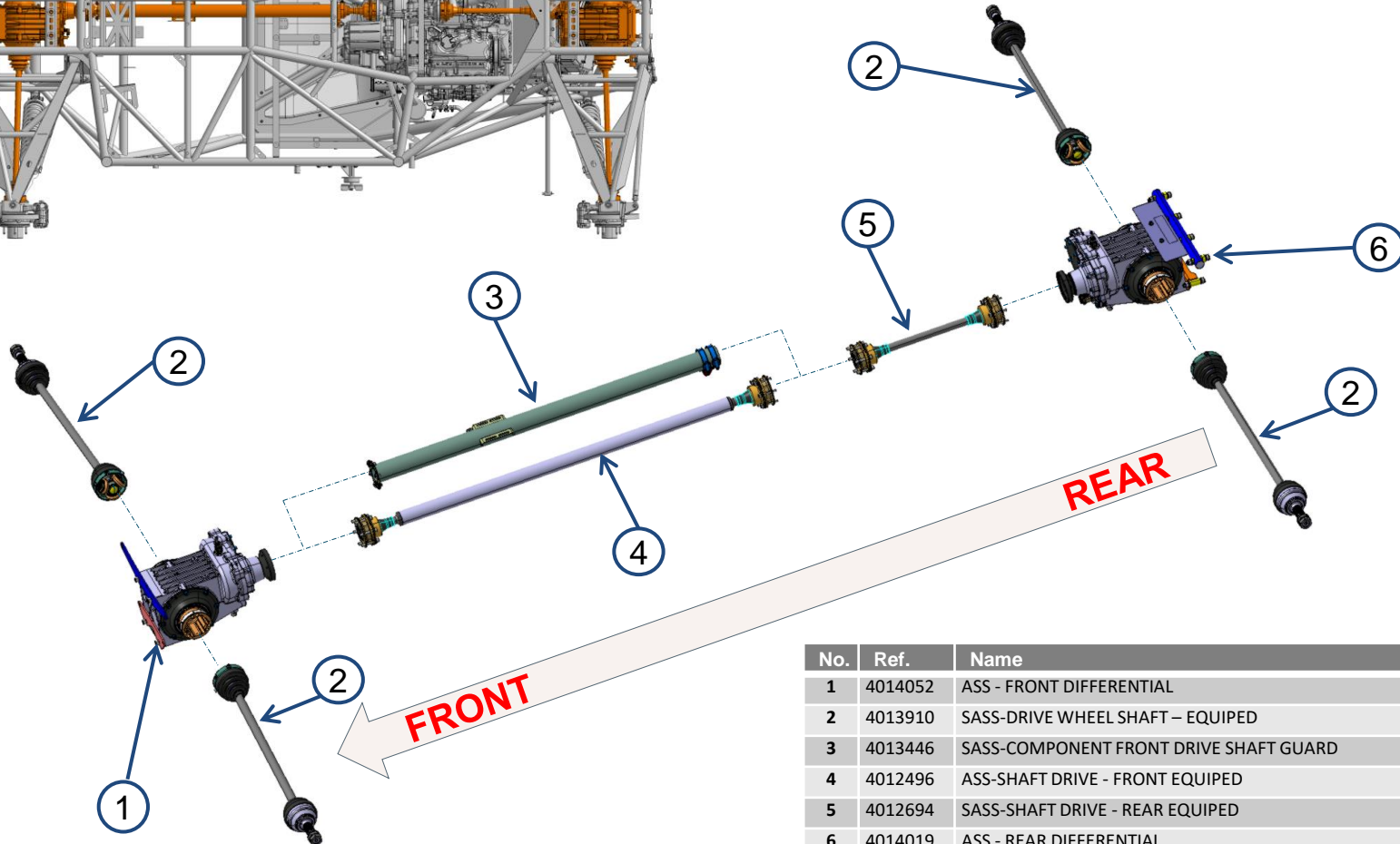
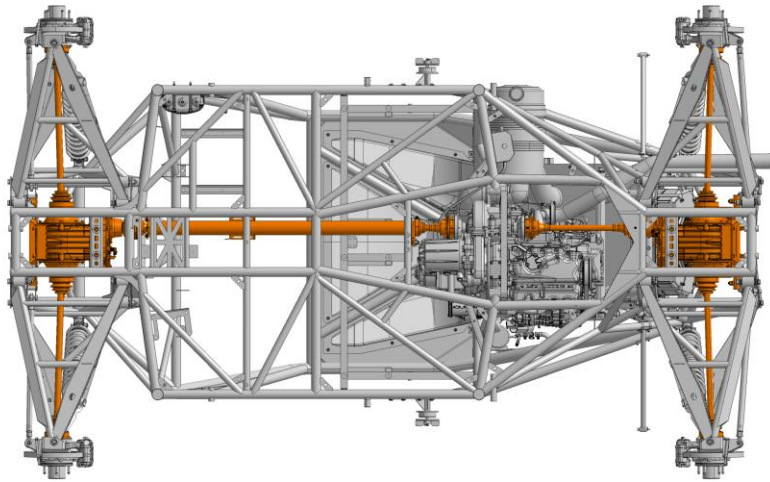

No.	Ref.	Name	Qty.
1	4014052	ASS - FRONT DIFFERENTIAL	1
2	4013910	SASS-DRIVE WHEEL SHAFT – EQUIPED	4
3	4013446	SASS-COMPONENT FRONT DRIVE SHAFT GUARD	1
4	4012496	ASS-SHAFT DRIVE - FRONT EQUIPED	1
5	4012694	SASS-SHAFT DRIVE - REAR EQUIPED	1
6	4014019	ASS - REAR DIFFERENTIAL	1



## 10.2.1 DRIVETRAIN – Front Differential Overview



### 3mo Performance Differential Assembly / Servicing Book

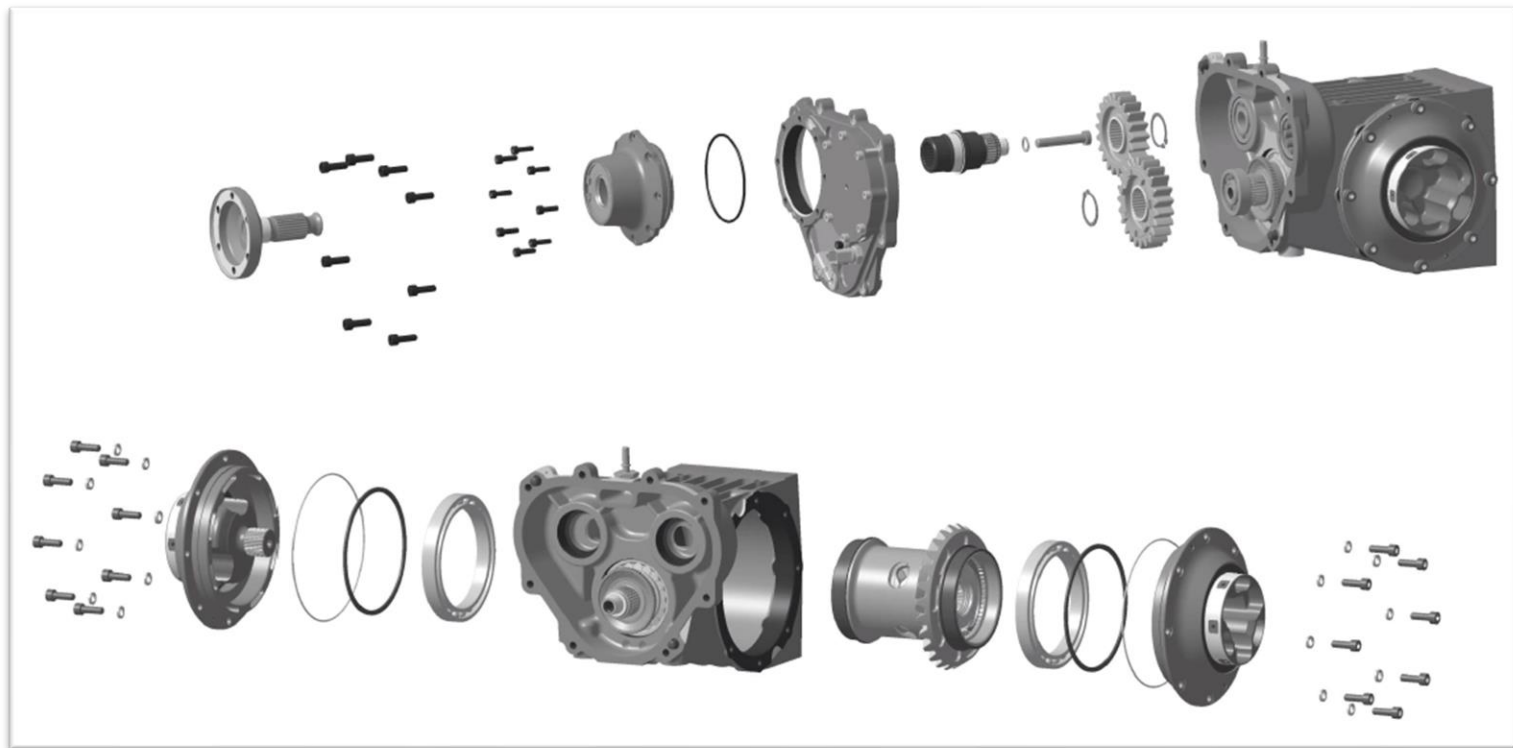

## 10.2.2 DRIVETRAIN – Front Differential – Preassembly

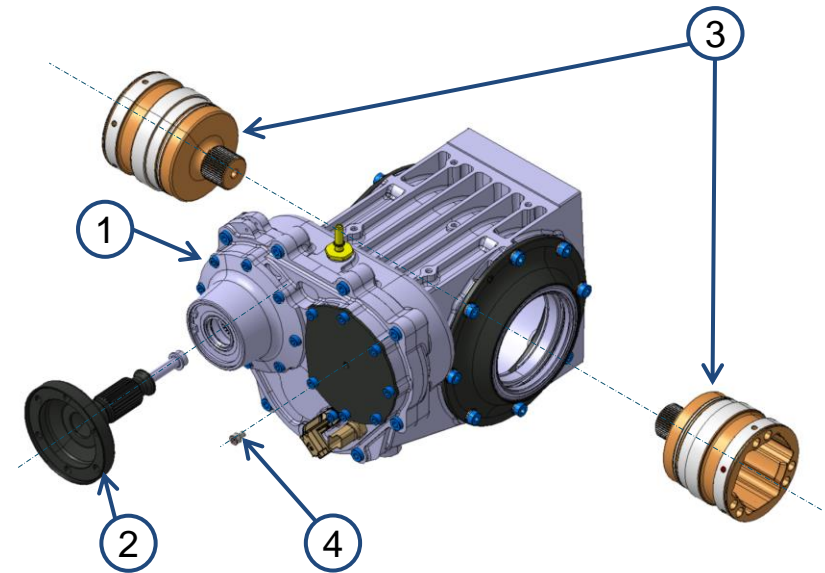
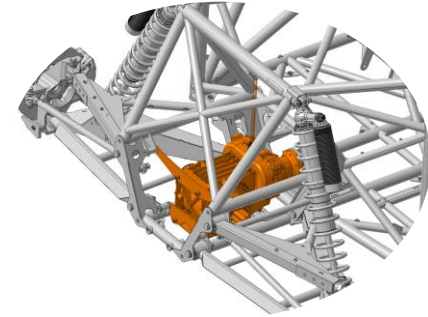

Following Document Ref:

[9068\\_Pont\\_DGD\\_Catalogue\\_indD\\_\(3MO\).pdf](#)

No.	Ref.	Number-Version-Name	Qty.
1	4012291	SASS-FRONT DIFFERENTIAL EQUIPED	1
2	4012293	COP-DIFFERENTIAL TULIP FLANGE	1
3	4012870	COP-TRIPOD DRIVE BALL JOINT AAR T3P 45DTS	2
4	4000582	SUP-HEXAGONAL SOCKET CAP SCREW ISO 4762 M6X8-8 P100 CL10.9 A B	1

# 10.2.3 DRIVETRAIN – Front Differential – Overview

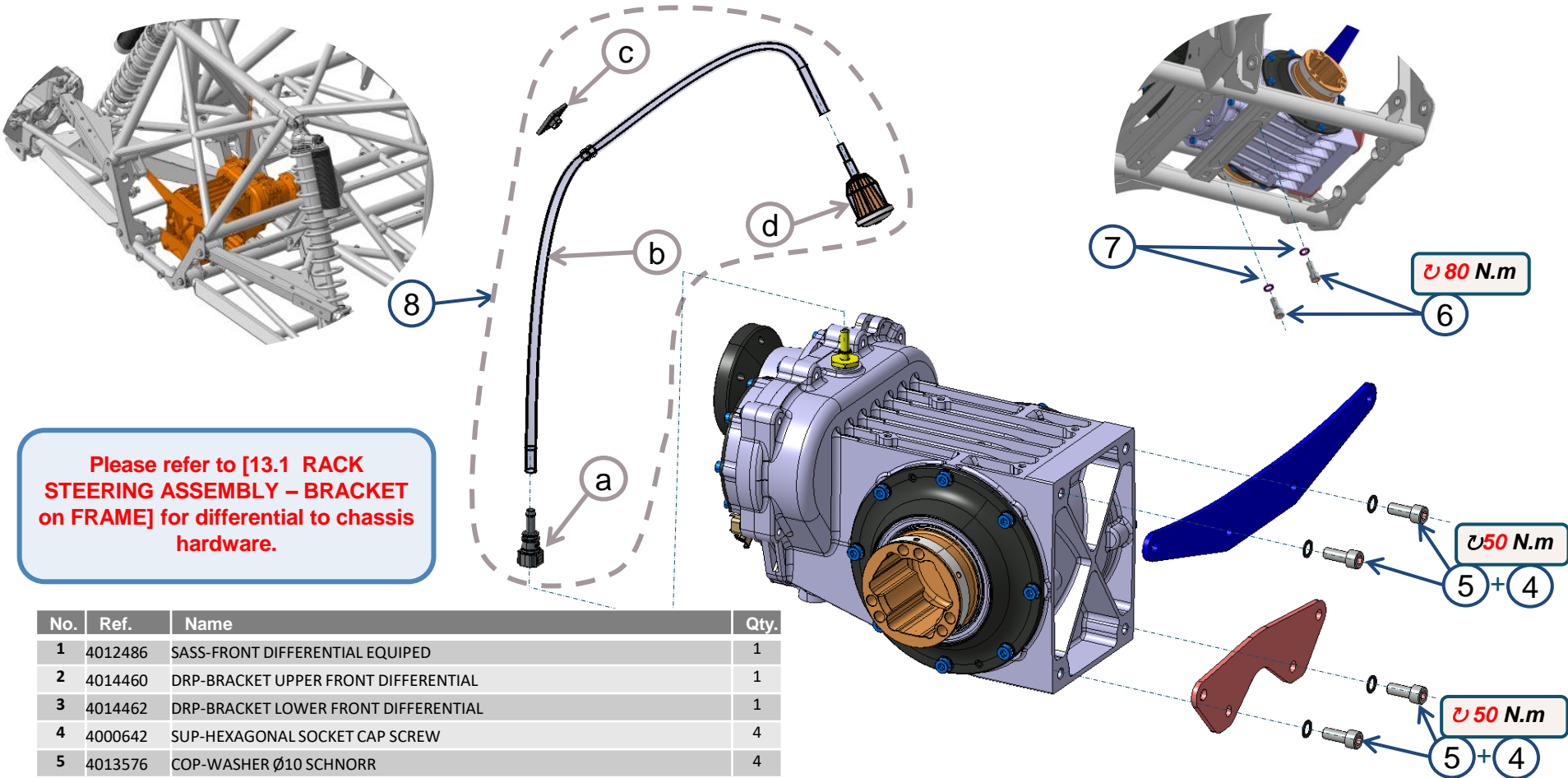

Please refer to [13.1 RACK STEERING ASSEMBLY – BRACKET on FRAME] for differential to chassis hardware.

No.	Ref.	Name	Qty.
1	4012486	SASS-FRONT DIFFERENTIAL EQUIPED	1
2	4014460	DRP-BRACKET UPPER FRONT DIFFERENTIAL	1
3	4014462	DRP-BRACKET LOWER FRONT DIFFERENTIAL	1
4	4000642	SUP-HEXAGONAL SOCKET CAP SCREW	4
5	4013576	COP-WASHER Ø10 SCHNORR	4
6	4001024	SUP-HEXAGONAL SOCKET CAP SCREW	2
7	4013574	COP-WASHER NORDLOCK Ø12	2
8	4015142	SASS-HOSE FRONT DIFFERENTIAL BREATHER →	1
a	4018117	COP-CONNECTOR EFI 8MM STRAIGHT	1
b	4018117	DRP-HOSE TRANSPARENT – Ø8MM – RECUT LENGTH 600MM	1
c	4013292	COP-BASE FLEXIBLE & SELF-ADHESIVE – Zip-tie	1
d	4017719	COP-FILTER DIFFERENTIAL VENTILATION FILTER	1

# 10.3.1 DRIVETRAIN – Wheel Shaft – Overview

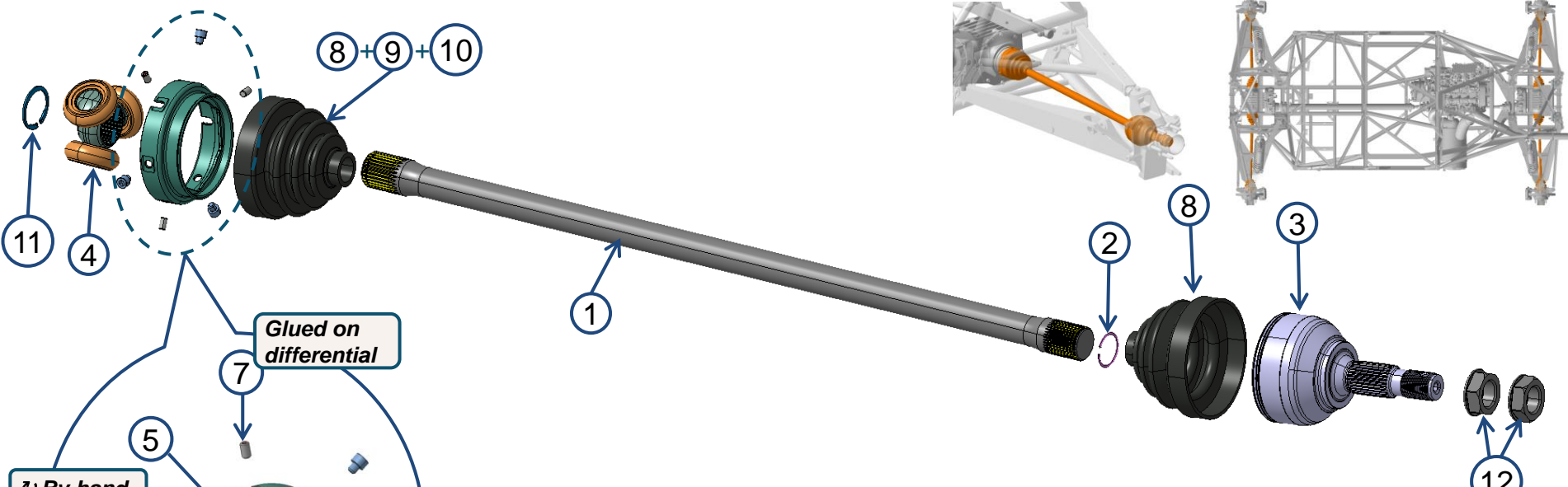

Applicable for the 4 wheels  
(Front – Rear – Right – Left)

⤴ **300 N.m + Loctite 271 +**  
**Marking on as shown on**  
**picture below**

No.	Ref.	Name	Qty.
1	4012853	DRP-DRIVE WHEEL SHAFT	1
2	4012891	COP-RING WHEEL SHAFT	1
3	4012863	COP-WHEEL JOINT	1
4	4012874	COP-TRIPOD AAR MALE	1
5	4012871	COP-BELLOWS HOLDER	1
6	4013892	COP-SCREW TCHC M6X6	3
7	4006224	SUP-HEXAGONAL SOCKET SCREW WITH FLAT POINT	3
8	4012879	COP-BOOT - BIG END SIDE	1
9	4012880	COP-BOOT COLLAR - BIG END SIDE	1
10	4012881	COP-BOOT COLLAR - SHAFT SIDE	1
11	4012896	SUP-EXTERNAL CIRCLIPS	1
12	4013903	COP-NUT M24X1.5 A EMBASE BAS	2

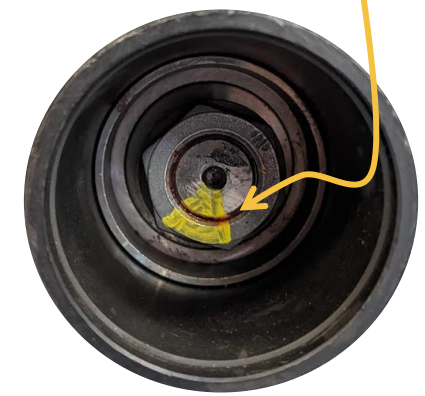

# 10.3.1 DRIVETRAIN – Wheel Shaft – Ligarex

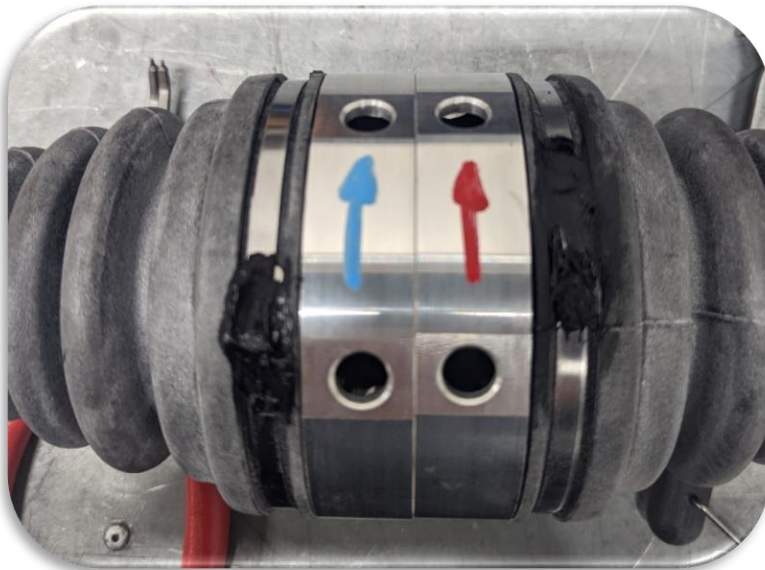
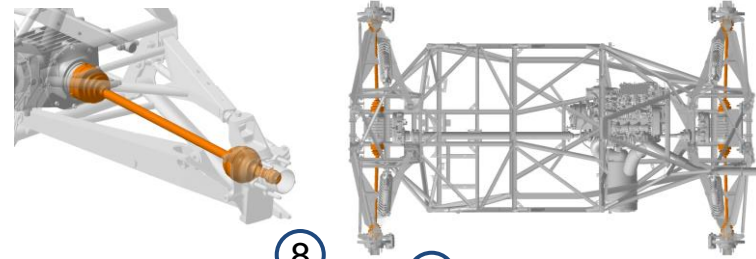
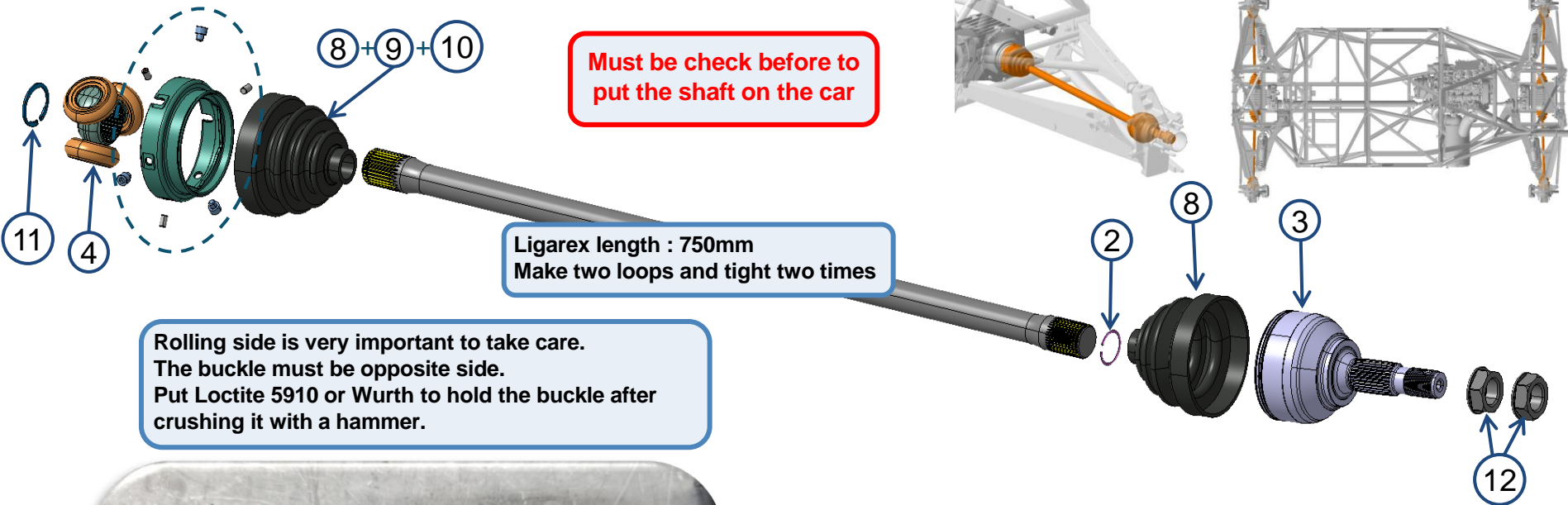

**The ligarex must be folded under the buckle**



## 10.3.3 DRIVETRAIN – Wheel Shaft – Assembly instructions

### TO DO List:

- 1) **On Wheel side:** Check if is there paint on the bearing contact area. **Remove the paint** if necessary

- 2) **Tripod assembly:** mounting aid chamfer on **the shaft side**

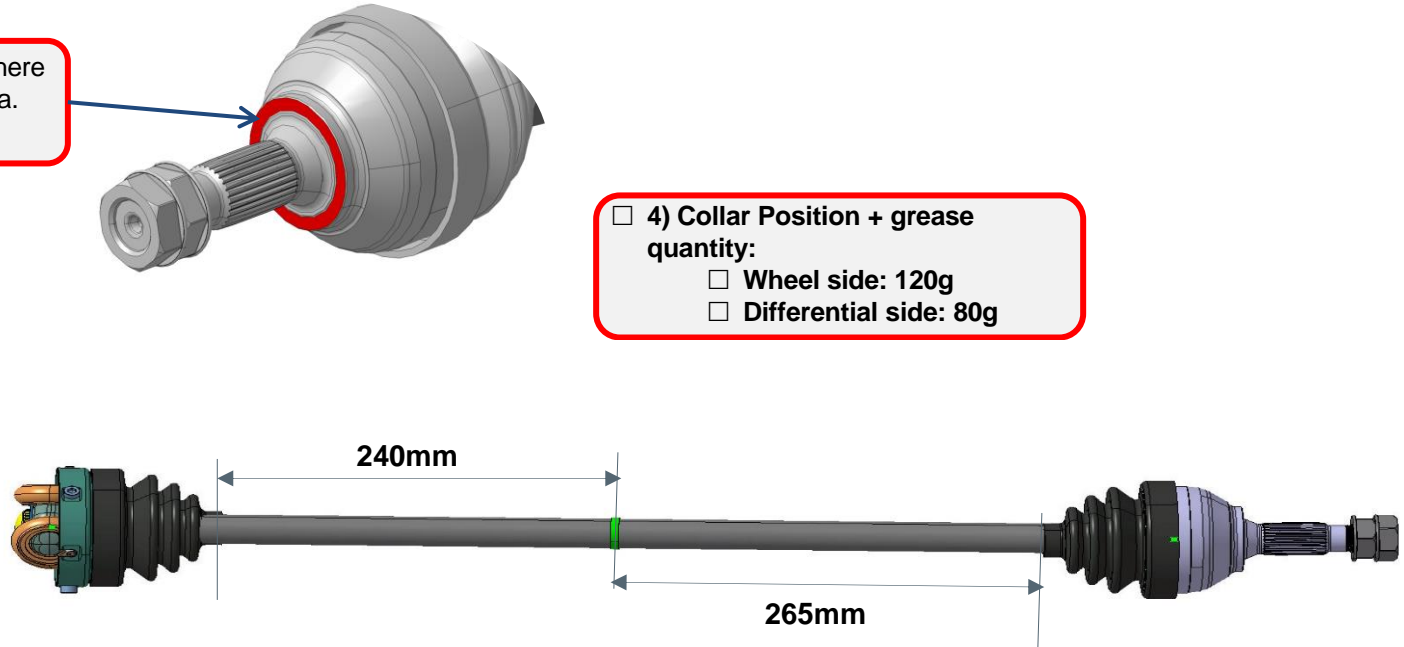
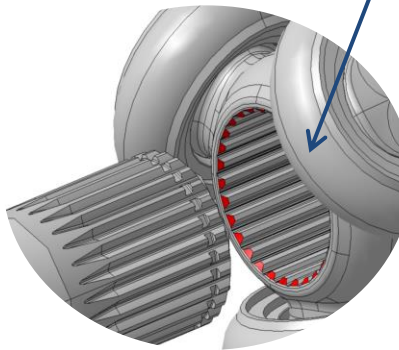

- 4) **Collar Position + grease quantity:**
  - Wheel side: 120g
  - Differential side: 80g

- 3) **Boots assembly process:**
  - Remove original collar from the boot
  - Degrease the boot and its support
  - Glue boot on its support using Loctite 5910
  - Finally apply glue on collar closure

- 5) **SHC screws must be glued** on differential to preserve tripod orientation

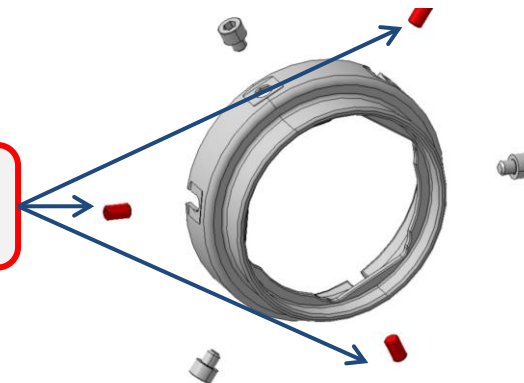

# 10.4.1 DRIVETRAIN – Front Drive Shaft Guard – 2023 VERSION

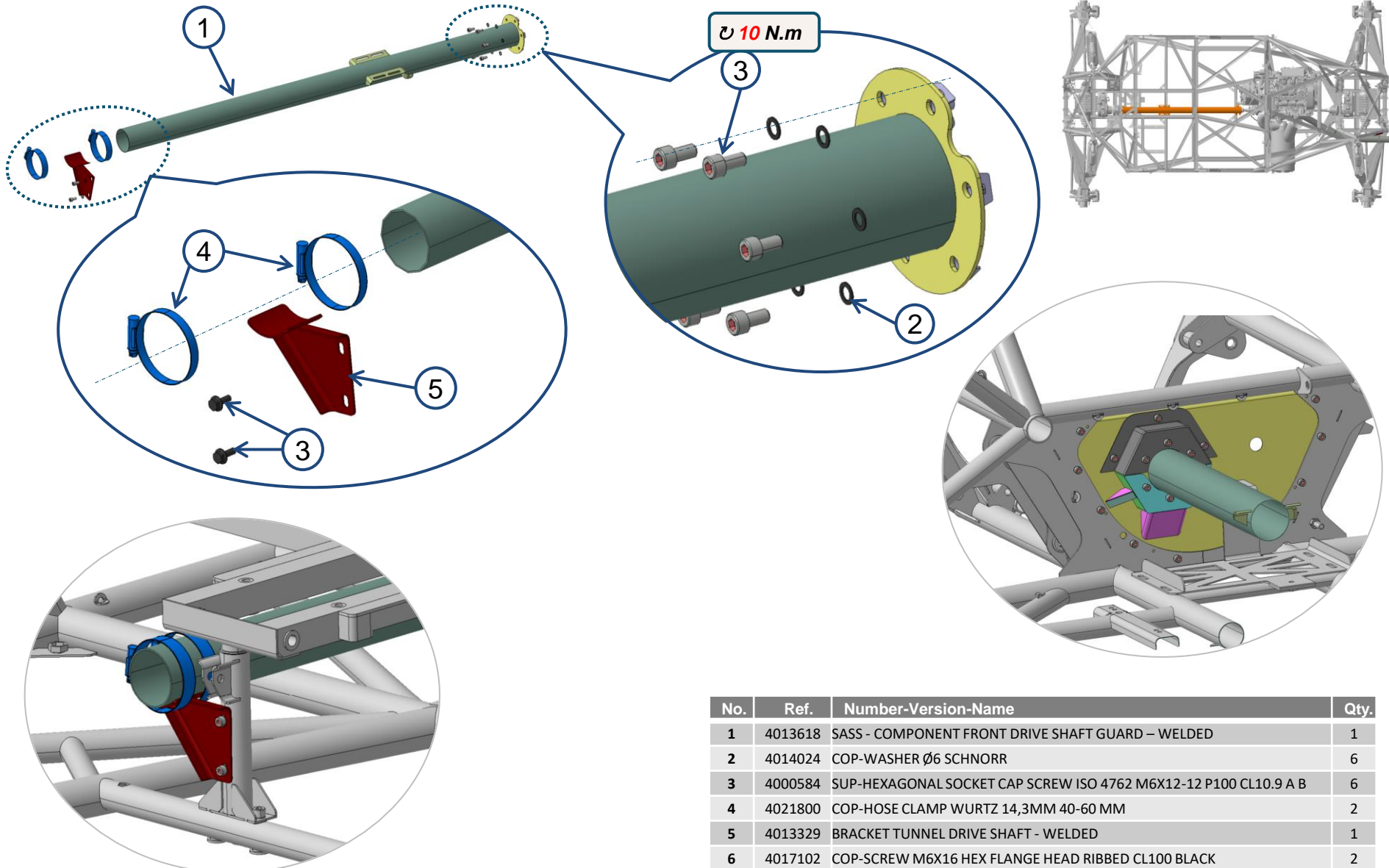

No.	Ref.	Number-Version-Name	Qty.
1	4013618	SASS - COMPONENT FRONT DRIVE SHAFT GUARD – WELDED	1
2	4014024	COP-WASHER Ø6 SCHNORR	6
3	4000584	SUP-HEXAGONAL SOCKET CAP SCREW ISO 4762 M6X12-12 P100 CL10.9 A B	6
4	4021800	COP-HOSE CLAMP WURTZ 14,3MM 40-60 MM	2
5	4013329	BRACKET TUNNEL DRIVE SHAFT - WELDED	1
6	4017102	COP-SCREW M6X16 HEX FLANGE HEAD RIBBED CL100 BLACK	2

## 10.4.2 DRIVETRAIN – Front Drive Shaft Guard – 2024 VERSION

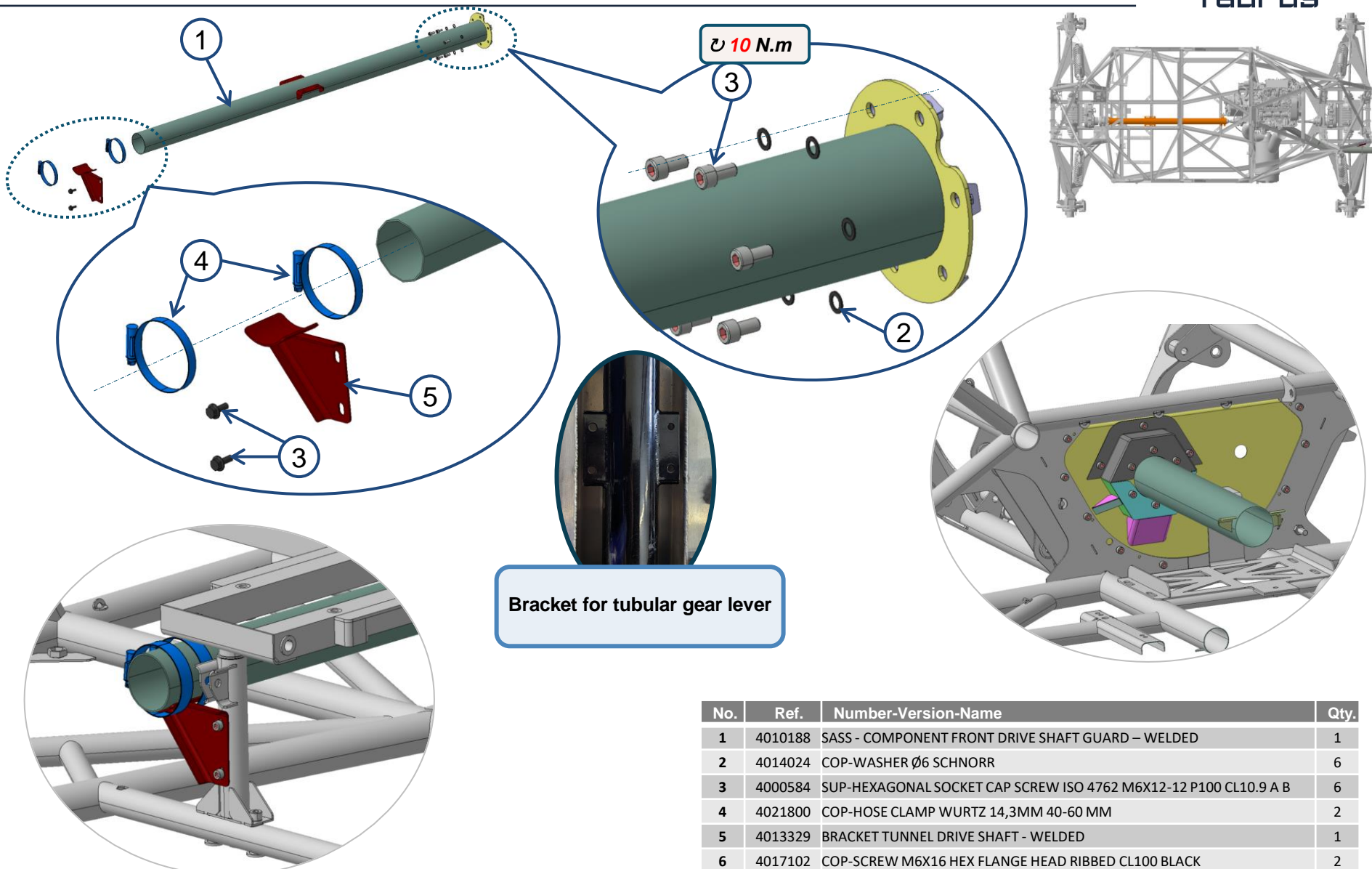

Bracket for tubular gear lever

No.	Ref.	Number-Version-Name	Qty.
1	4010188	SASS - COMPONENT FRONT DRIVE SHAFT GUARD – WELDED	1
2	4014024	COP-WASHER Ø6 SCHNORR	6
3	4000584	SUP-HEXAGONAL SOCKET CAP SCREW ISO 4762 M6X12-12 P100 CL10.9 A B	6
4	4021800	COP-HOSE CLAMP WURTZ 14,3MM 40-60 MM	2
5	4013329	BRACKET TUNNEL DRIVE SHAFT - WELDED	1
6	4017102	COP-SCREW M6X16 HEX FLANGE HEAD RIBBED CL100 BLACK	2



# 10.4.3 DRIVETRAIN – Front Drive Shaft Guard – 2024 VERSION

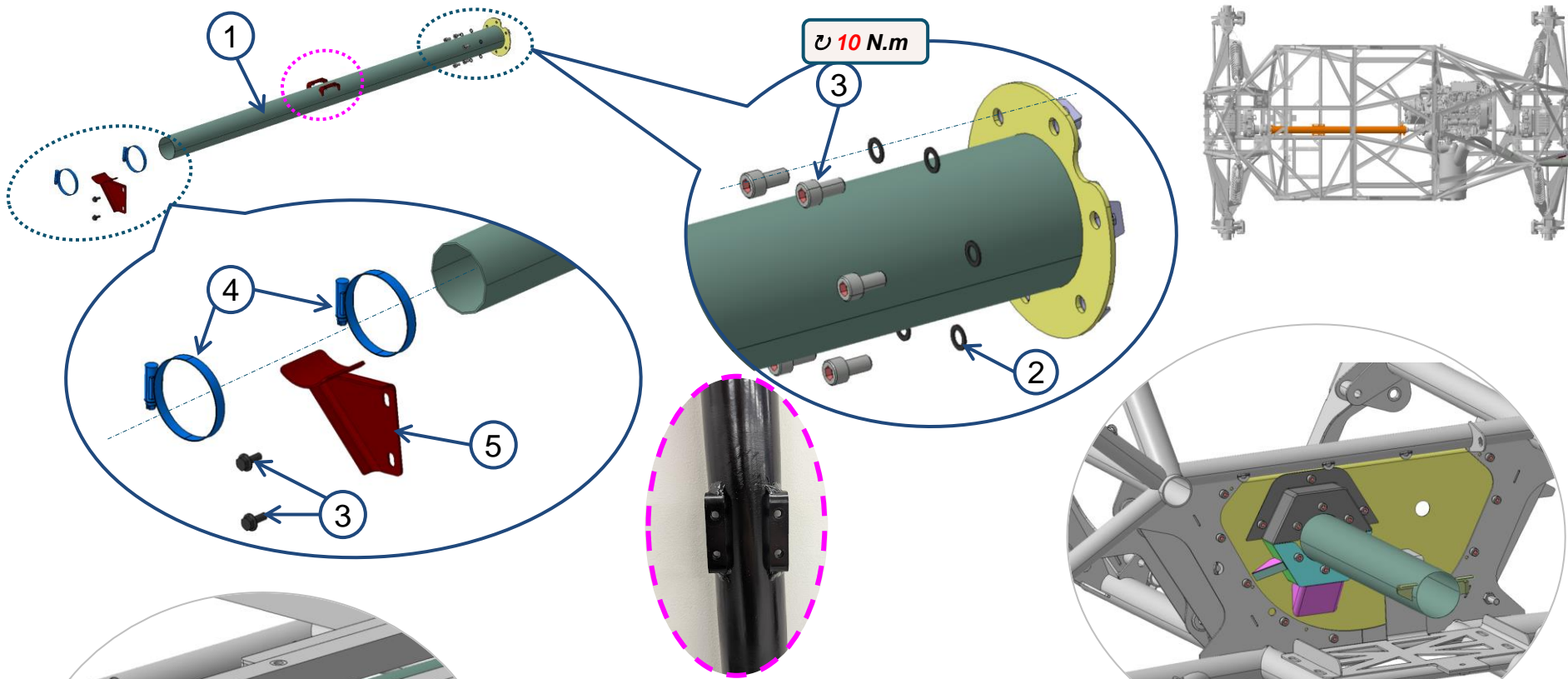

**Bracket for machined gear lever**

No.	Ref.	Number-Version-Name	Qty.
1	4011014	SASS - COMPONENT FRONT DRIVE SHAFT GUARD – WELDED	1
2	4014024	COP-WASHER Ø6 SCHNORR	6
3	4000584	SUP-HEXAGONAL SOCKET CAP SCREW ISO 4762 M6X12-12 P100 CL10.9 A B	6
4	4021800	COP-HOSE CLAMP WURTZ 14,3MM 40-60 MM	2
5	4013329	BRACKET TUNNEL DRIVE SHAFT - WELDED	1
6	4017102	COP-SCREW M6X16 HEX FLANGE HEAD RIBBED CL100 BLACK	2

## 10.5.1 DRIVETRAIN – Seat bench – 2023 VERSION

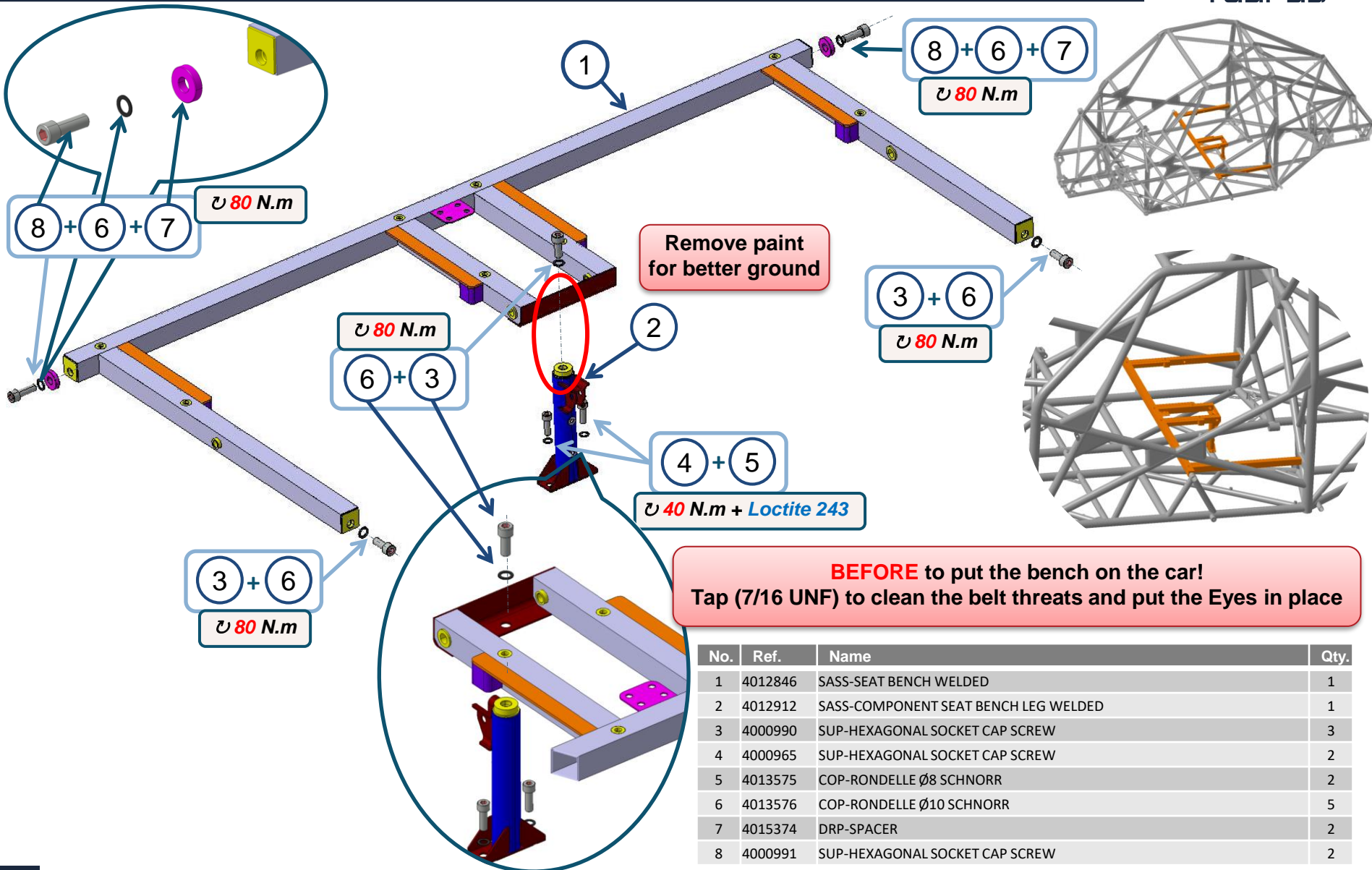

# Composite fuel tank



## 10.5.2 DRIVETRAIN – Seat bench – 2024 VERSION

⤵ 40 N.m + Loctite 243

7 + 8

Add foam [ref] below the spacer to compress the tank.

9

1

2

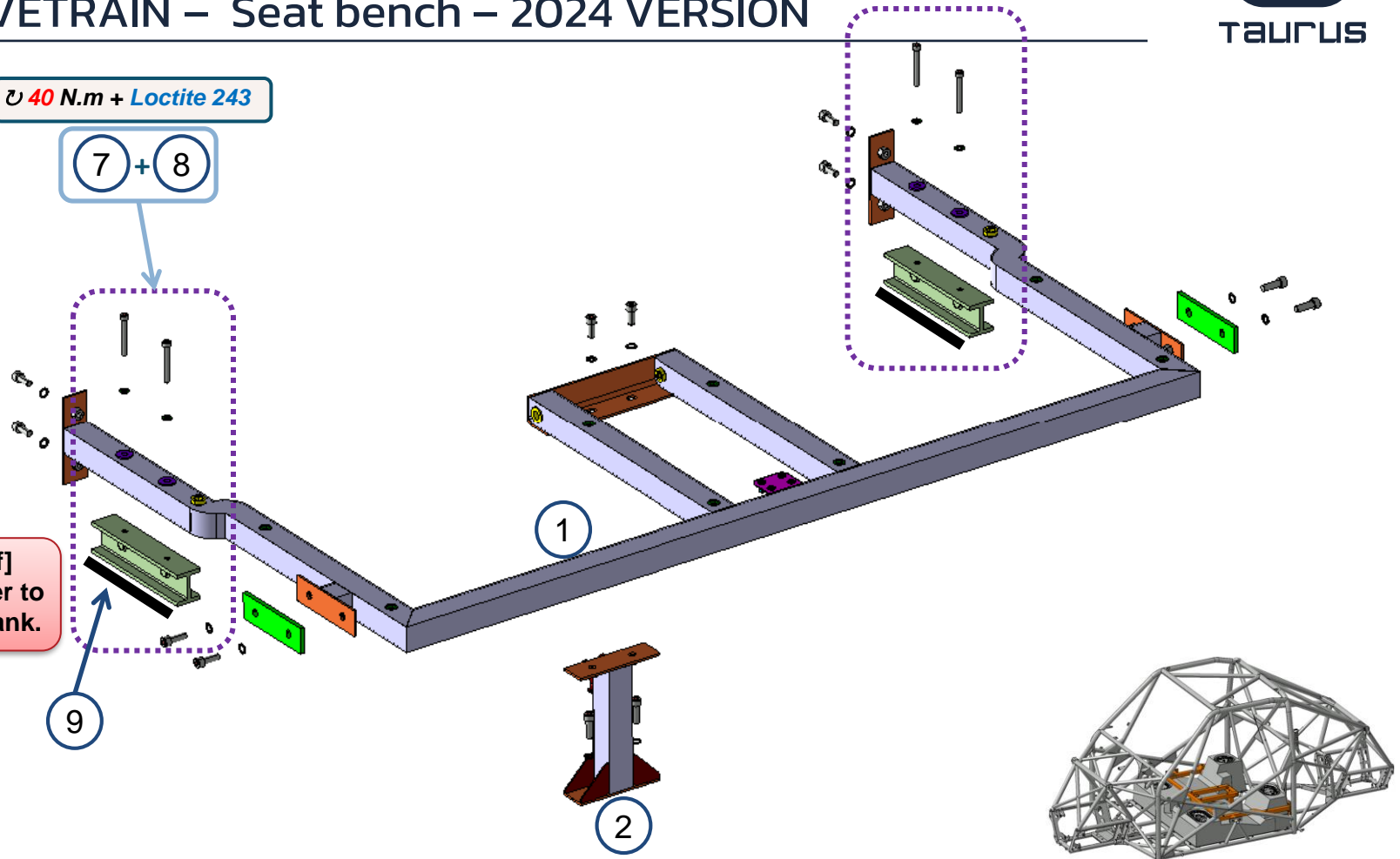

No.	Ref.	Name	Qty.
1	4020364	SASS-SEAT BENCH WELDED	1
2	4020380	SASS-COMPONENT SEAT BENCH LEG WELDED	1
7	4009150	DRP-SPACER FUEL TANK	4
8	4000943	SUP-PLAIN WASHER D6XD12X1.2 TYPE Z NFE25-514 A EZ	4
9	4021419	SUP-HEXAGONAL SOCKET CAP SCREW ISO 4762 M6X50-24 P100 CL12.9	2

# Composite fuel tank



## 10.5.3 DRIVETRAIN – Seat bench – 2024 VERSION

**BEFORE** to put the bench on the car!  
Tap (7/16 UNF) to clean the belt threads and put the Eyes in place

⌚ 40 N.m + Loctite 243

⌚ 40 N.m + Loctite 243

⌚ 40 N.m + Loctite 243

⌚ 40 N.m + Loctite 243

⌚ 40 N.m + Loctite 243

Remove paint for better ground

Remove paint for better ground

5 + 6

5 + 6

5 + 6

4 + 6

4 + 6

4 + 6

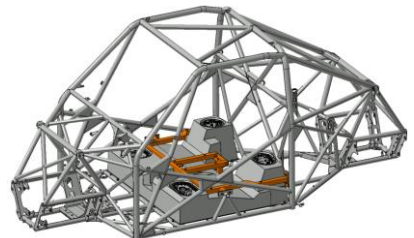
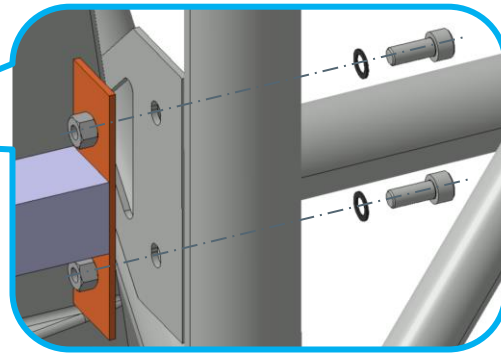
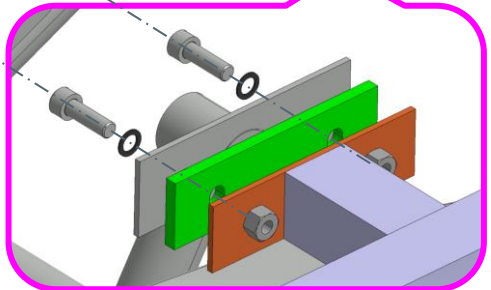

No.	Ref.	Name	Qty.
1	4020364	SASS-SEAT BENCH WELDED	1
2	4020380	SASS-COMPONENT SEAT BENCH LEG WELDED	1
3	4020381	DRP-SPACER SEAT BENCH	2
4	4000965	SUP-HEXAGONAL SOCKET CAP SCREW ISO 4762 M8X25-25 P125 CL12.9 A B	6
5	4000963	SUP-HEXAGONAL SOCKET CAP SCREW ISO 4762 M8X20-20 P125 CL12.9 A B	6
6	4013575	COP-WASHER Ø8 SCHNORR	12

## 10.5.3 SEATBENCH – Seat Bench load Strut

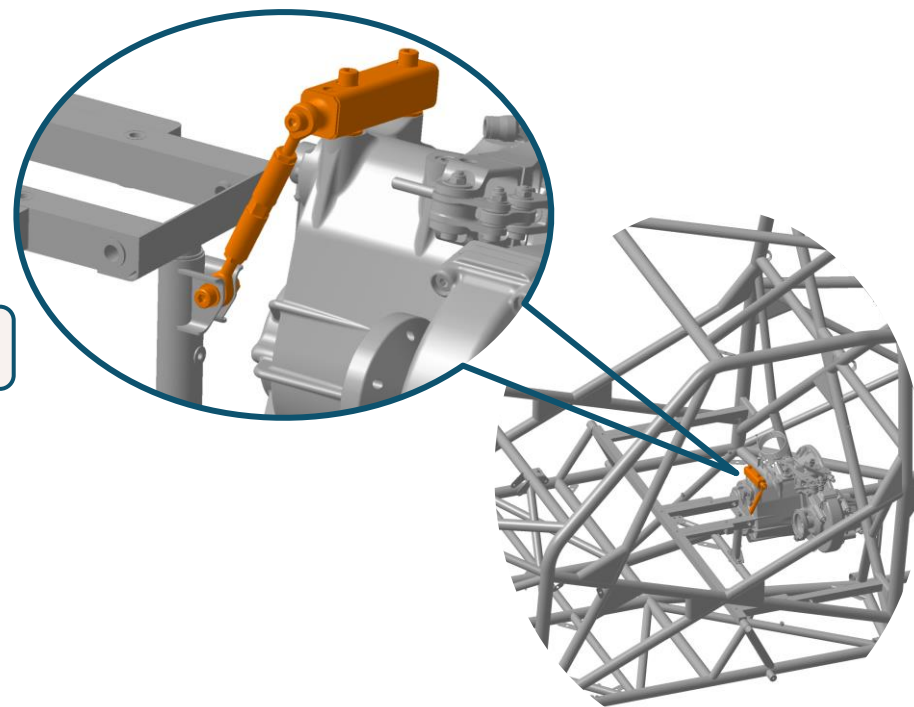
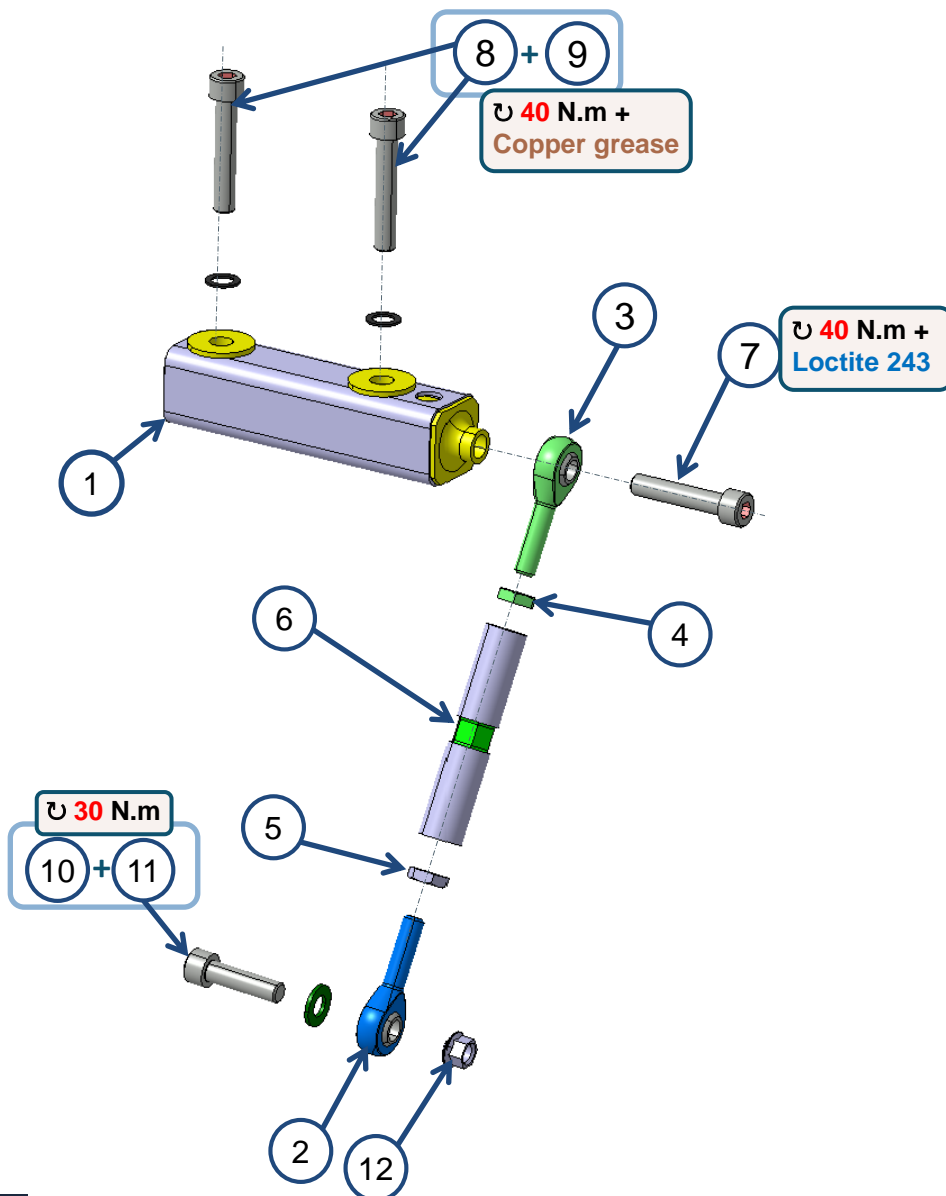

No.	Ref.	Name	Qty.
1	4013160	SASS - SUPPORT DE JAMBE DE FORCE TREILLIS DE SIEGE	1
2	4012397	COP-BALL JOINT UNIBAL SMG 8 RIGHT	1
3	4012398	COP-BALL JOINT UNIBAL SMLG 8 LEFT	1
4	4012403	SUP-JAM NUT M8 P125 L4MM CL8 - LEFT THREADED	1
5	4012400	SUP-JAM NUT M8 P125 L4MM CL8	1
6	4013207	DRP-ROD SEAT BENCH	1
7	4000968	SUP-HEXAGONAL SOCKET CAP SCREW ISO 4762 M8X40-28 P125 CL12.9 A	1
8	4000969	SUP-HEXAGONAL SOCKET CAP SCREW ISO 4762 M8X45-28 P125 CL12.9 A B	2
9	4013575	COP-WASHER Ø8 SCHNORR	2
10	4000966	SUP-HEXAGONAL SOCKET CAP SCREW ISO 4762 M8X30-28 P125 CL12.9 A B	1
11	4009151	SUP-PLAIN WASHER D8XD16X1.5 TYPE Z NFE25-514 A EZ	1
12	4014322	SUP-LOCKNUT WITH FLANGE - M8X1.25 - SIMMONDS	1

## 10.6.2 DRIVETRAIN – Front and Rear Drive Shaft – Preassembly

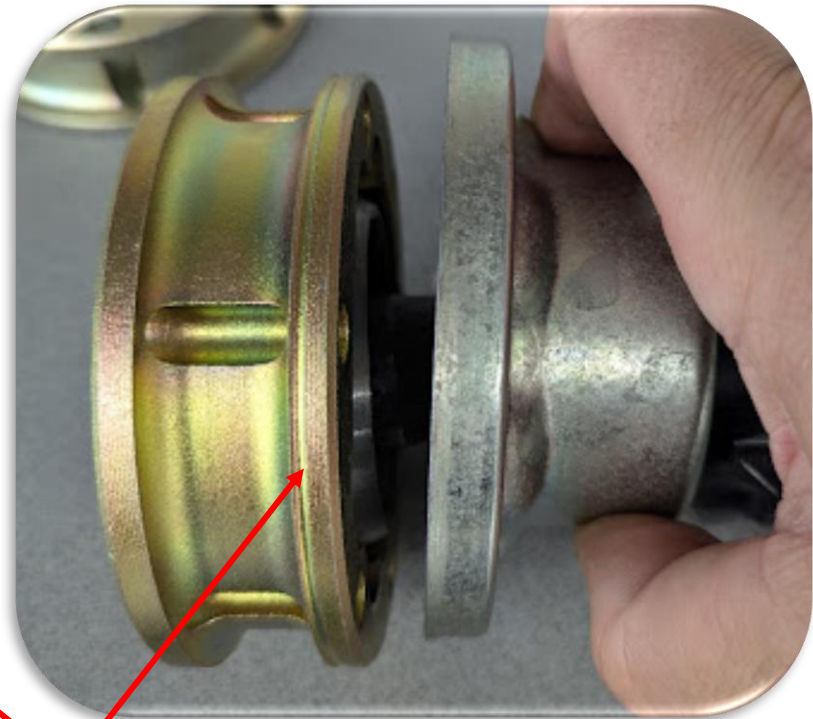

**The groove must be shaft  
and boot side**

# 10.6.3 DRIVETRAIN – Front Drive Shaft – Overview

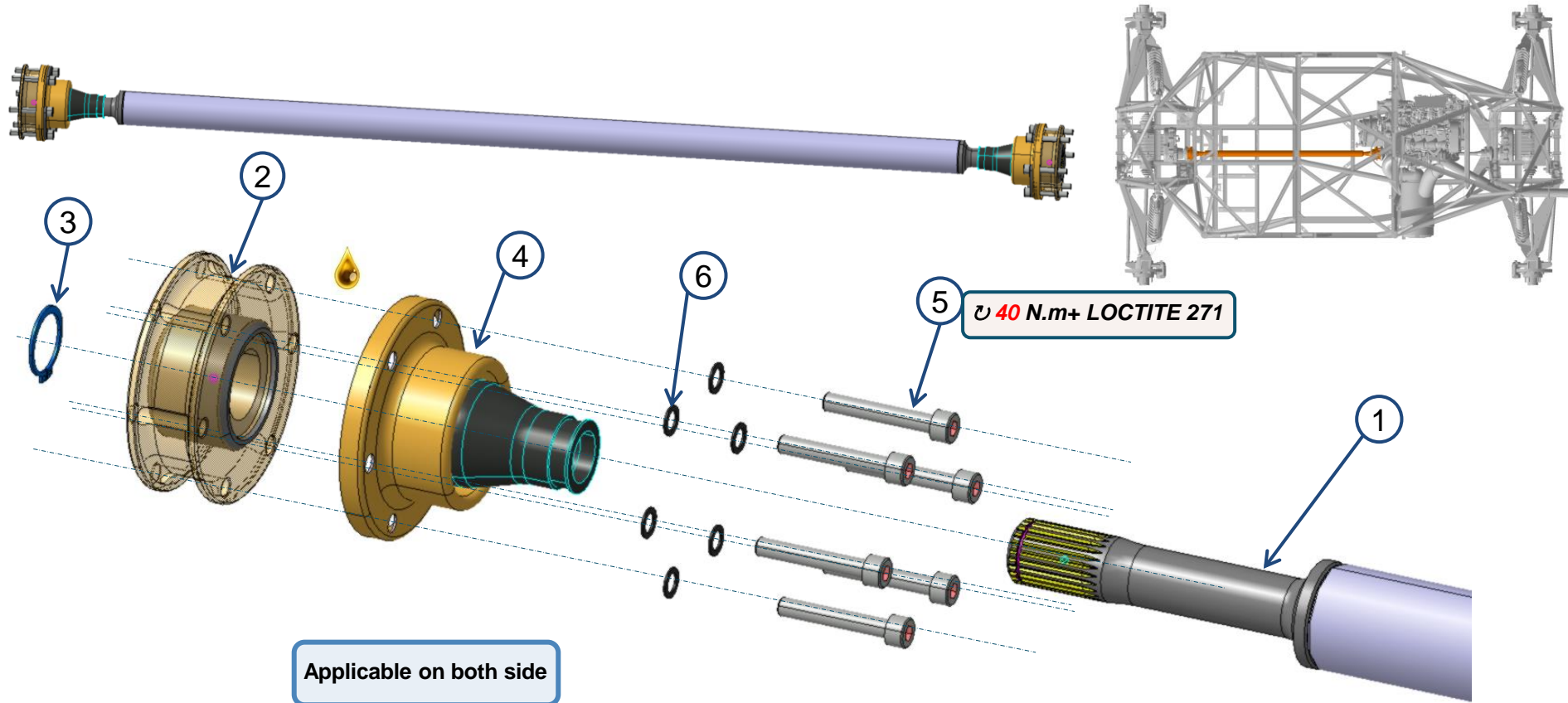

**Day before mounting**  
**Gearbox Side :**  
 -grease each ball + put grease in bellows  
 -stick the bellows with 5910  
 -Put grease HPCC1 ( 4015480)in bowl

→ Total grease weight for all : **60grs**

No.	Ref.	Name	Qty.
1	4012495	SHAFT WELDED - DRIVE FRONT	1
2	4012491	COP-CONSTANT VELOCITY JOINT OD 100	2
3	4012497	SUP-EXTERNAL CIRCLIPS D26X1.2 - DIN 471 A	2
4	4012515	COP-CUP BOOT FOR GKN 100MM	2
5	4000622	SUP-HEXAGONAL SOCKET CAP SCREW ISO 4762 M8X50-28 P125 CL10.9 A B	12
6	4013575	COP-WASHER Ø8 SCHNORR	12
8	4015480	COP-GREASE HPCC1	

# 10.6.4 DRIVETRAIN – Rear Drive Shaft – Overview

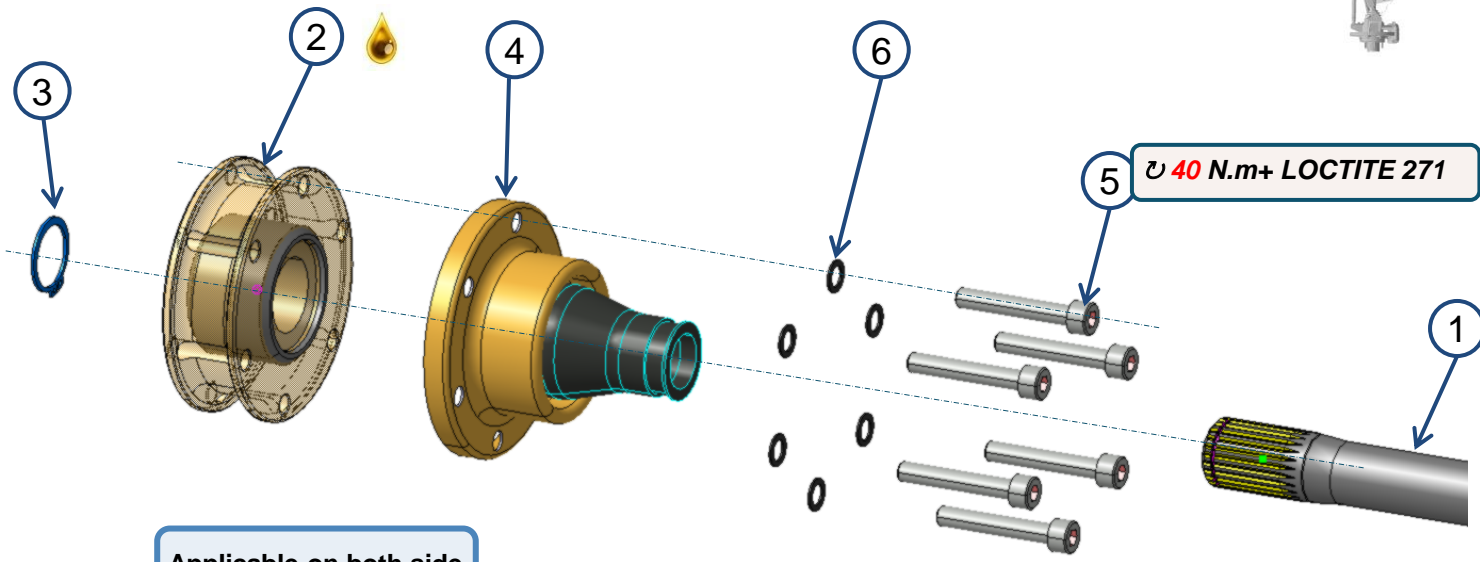
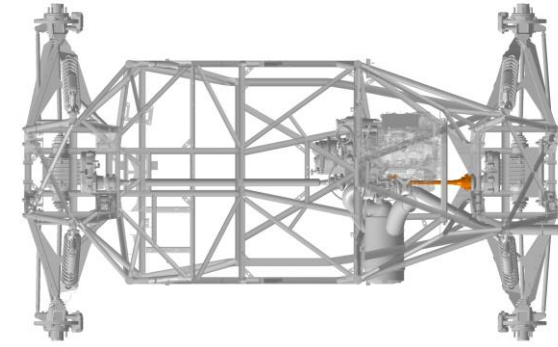
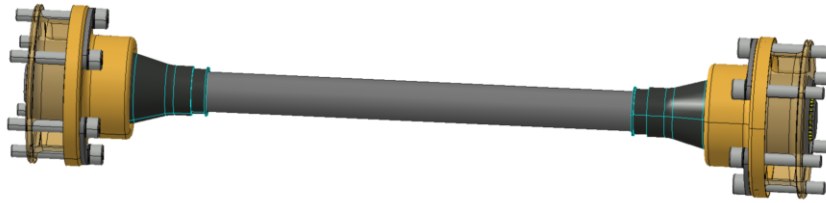

Applicable on both side

**Day before mounting** 

**Gearbox Side :**

- grease each ball + put grease in bellows
- stick the bellows with 5910
- Put grease in bowl HPCC1 ( 4015480)

→ **Totally grease weight for all : 60grs**

No.	Ref.	Name	Qty.
1	4012547	DRP-SHAFT DRIVE - REAR – CARVED	1
2	4012491	COP-CONSTANT VELOCITY JOINT OD 100	2
3	4012497	SUP-EXTERNAL CIRCLIPS D26X1.2 - DIN 471 A	2
4	4012515	COP-CUP BOOT FOR GKN 100MM	2
5	4000622	SUP-HEXAGONAL SOCKET CAP SCREW ISO 4762 M8X50-28 P125 CL10.9 A B	12
6	4013575	COP-WASHER Ø8 SCHNORR	12
7	4015480	COP-GREASE HPCC1	



# 10.7.1 REAR DIFFERENTIAL – Preassembly



## 3MO Performance Differential Assembly / Servicing Book

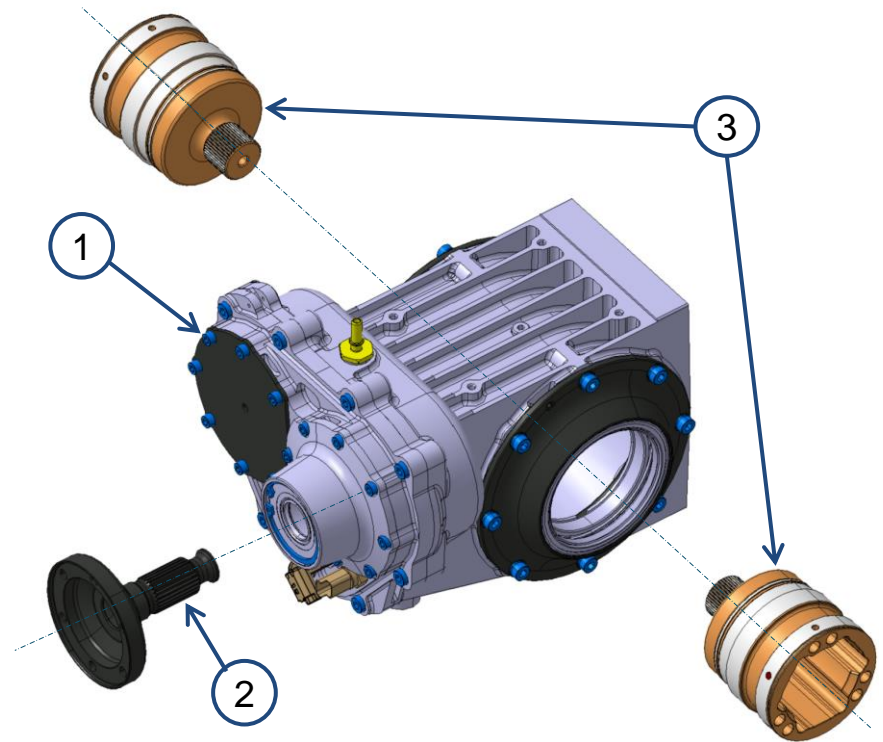
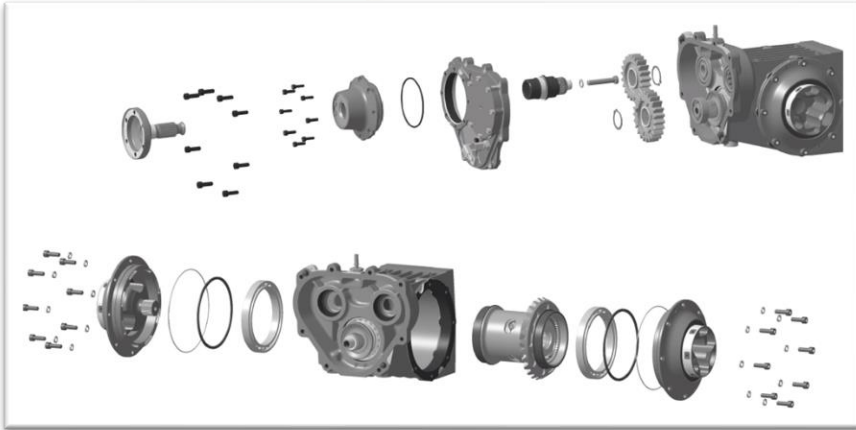
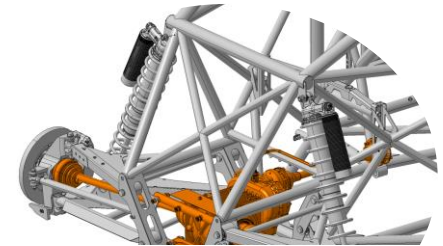

Following Document Ref:  
[9068\\_Pont\\_DGD\\_Catalogue\\_indD\\_\(3MO\).pdf](#)

No.	Ref.	Name	Qty.
1	4012292	COP-REAR DIFFERENTIAL	1
2	4012293	COP-DIFFERENTIAL TULIP FLANGE	1
3	4012870	COP-TRIPOD DRIVE BALL JOINT AAR T3P 45DTS	2

# 10.7.2 REAR DIFFERENTIAL – Overview

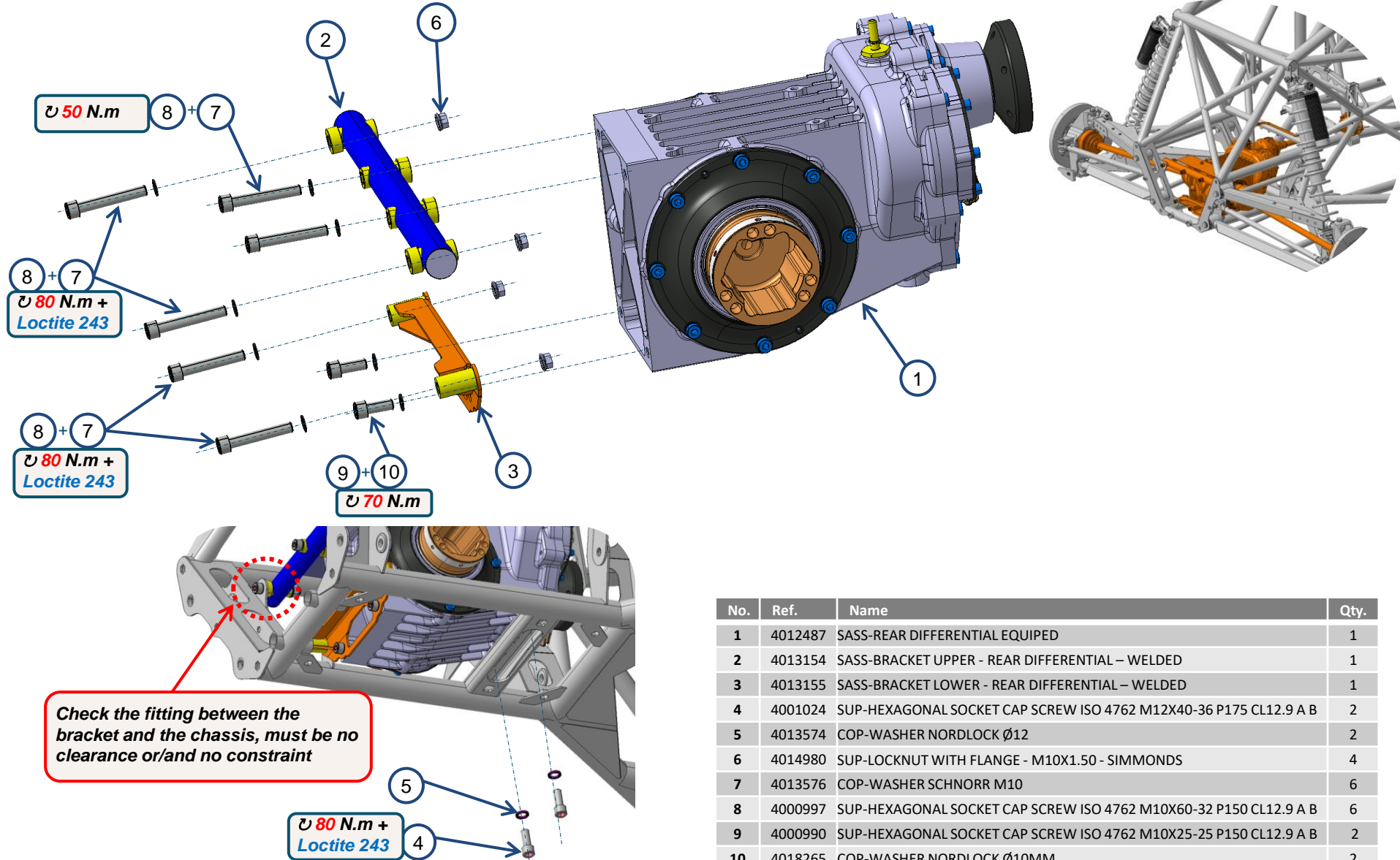

No.	Ref.	Name	Qty.
1	4012487	SASS-REAR DIFFERENTIAL EQUIPED	1
2	4013154	SASS-BRACKET UPPER - REAR DIFFERENTIAL – WELDED	1
3	4013155	SASS-BRACKET LOWER - REAR DIFFERENTIAL – WELDED	1
4	4001024	SUP-HEXAGONAL SOCKET CAP SCREW ISO 4762 M12X40-36 P175 CL12.9 A B	2
5	4013574	COP-WASHER NORDLOCK Ø12	2
6	4014980	SUP-LOCKNUT WITH FLANGE - M10X1.50 - SIMMONDS	4
7	4013576	COP-WASHER SCHNORR M10	6
8	4000997	SUP-HEXAGONAL SOCKET CAP SCREW ISO 4762 M10X60-32 P150 CL12.9 A B	6
9	4000990	SUP-HEXAGONAL SOCKET CAP SCREW ISO 4762 M10X25-25 P150 CL12.9 A B	2
10	4018265	COP-WASHER NORDLOCK Ø10MM	2

## 10.7.3 REAR DIFFERENTIAL – Breather

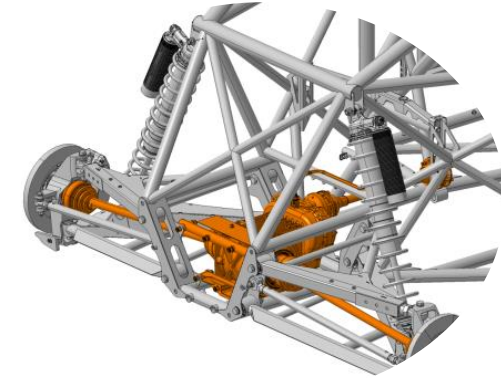
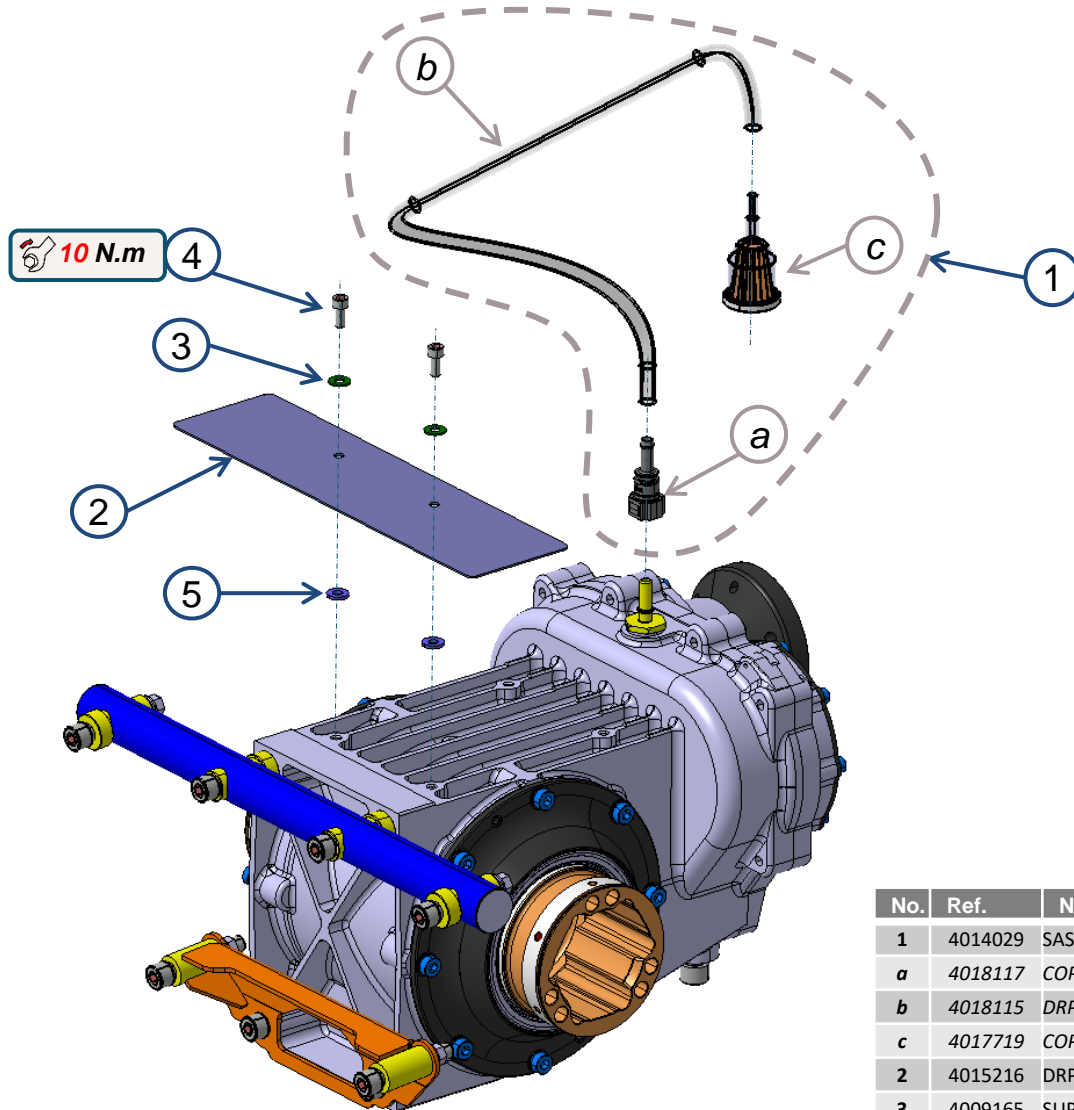

No.	Ref.	Name	Qty.
1	4014029	SASS-HOSE REAR DIFFERENTIAL BREATHER →	1
a	4018117	COP-CONNECTOR EFI 8MM STRAIGHT	1
b	4018115	DRP-HOSE TRANSPARENT - ØINT 8MM - RECUT LENGTH 640MM	1
c	4017719	COP-FILTER DIFFERENTIAL VENTILATION FILTER	1
2	4015216	DRP-COMPONENT DIFFERENTIAL COVER	1
3	4009165	SUP-PLAIN WASHER D6XD14X1.2 TYPE M NFE25-514 A EZ	2
4	4000933	SUP-HEXAGONAL SOCKET CAP SCREW ISO 4762 M6X14-14 P100 CL12.9 A B	2
5	4015309	DRP-SPACER Ø6.5 - Ø14 - L2	2

## Section 11

### BRAKES

### ■ Specific tool needed

- ▶ **Torque wrench : 5 → 25 Nm**
- ▶ **Torque wrench : 40 → Nm**

### ■ Specific sealing needed:

- ▶ **Loctite 271**
- ▶ **Copper grease**

# 11.1 BRAKES – Overview

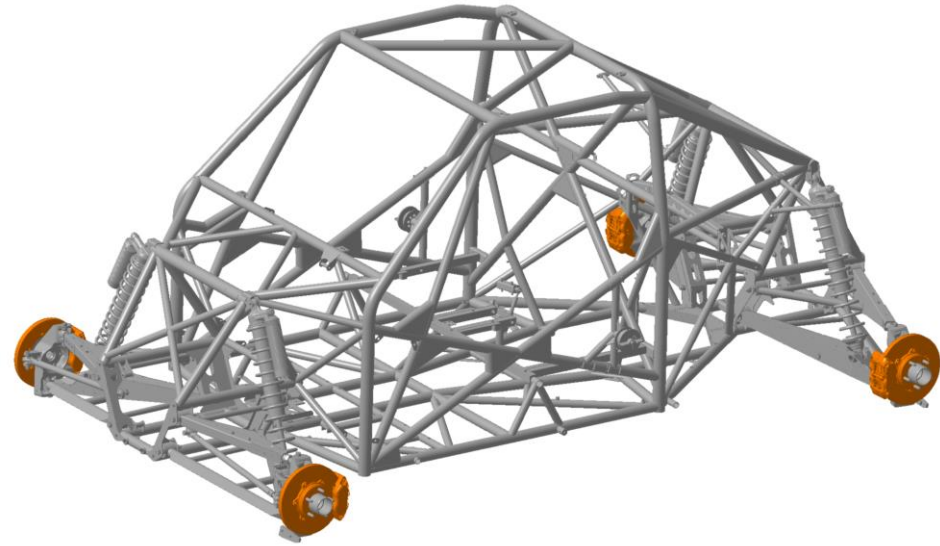
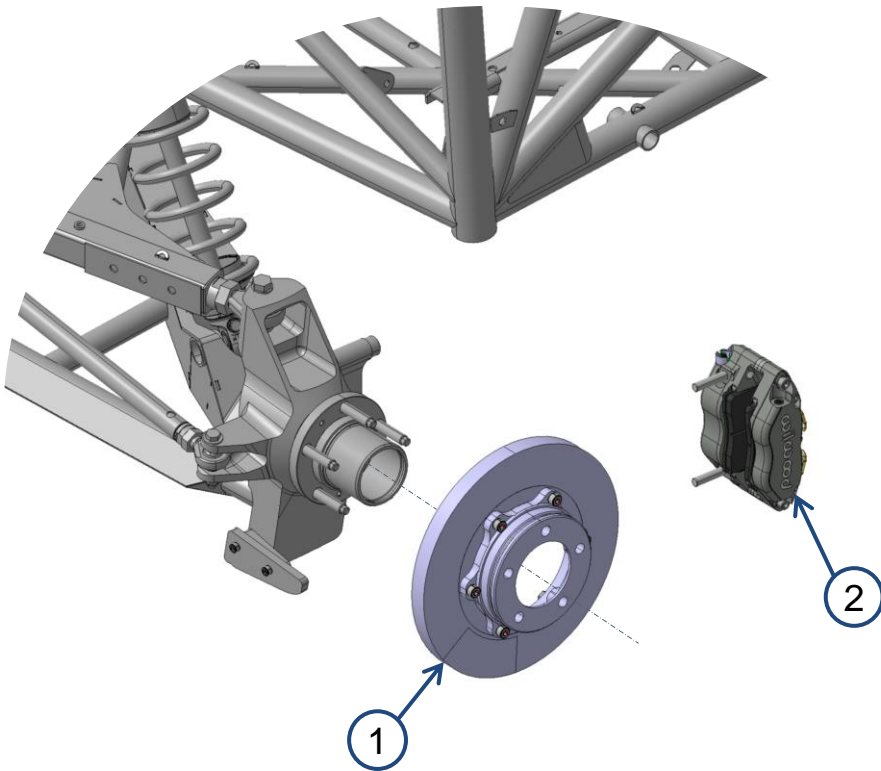

**Assembly Tips:**

- Identify each brake caliper

No.		Number-Version-Name	Qty.
1	4012790	SASS-DISC ASSEMBLED	4
2	4014155	SASS-COMPONENT BRAKE CALIPER EQUIPPED - FRONT LEFT	1
2	4014999	SASS-COMPONENT BRAKE CALIPER EQUIPPED - FRONT RIGHT	1
2	4012800	SASS-COMPONENT BRAKE CALIPER EQUIPPED - REAR LEFT	1
2	4015000	SASS-COMPONENT BRAKE CALIPER EQUIPPED - REAR RIGHT	1

# 11.2 BRAKES – Disc

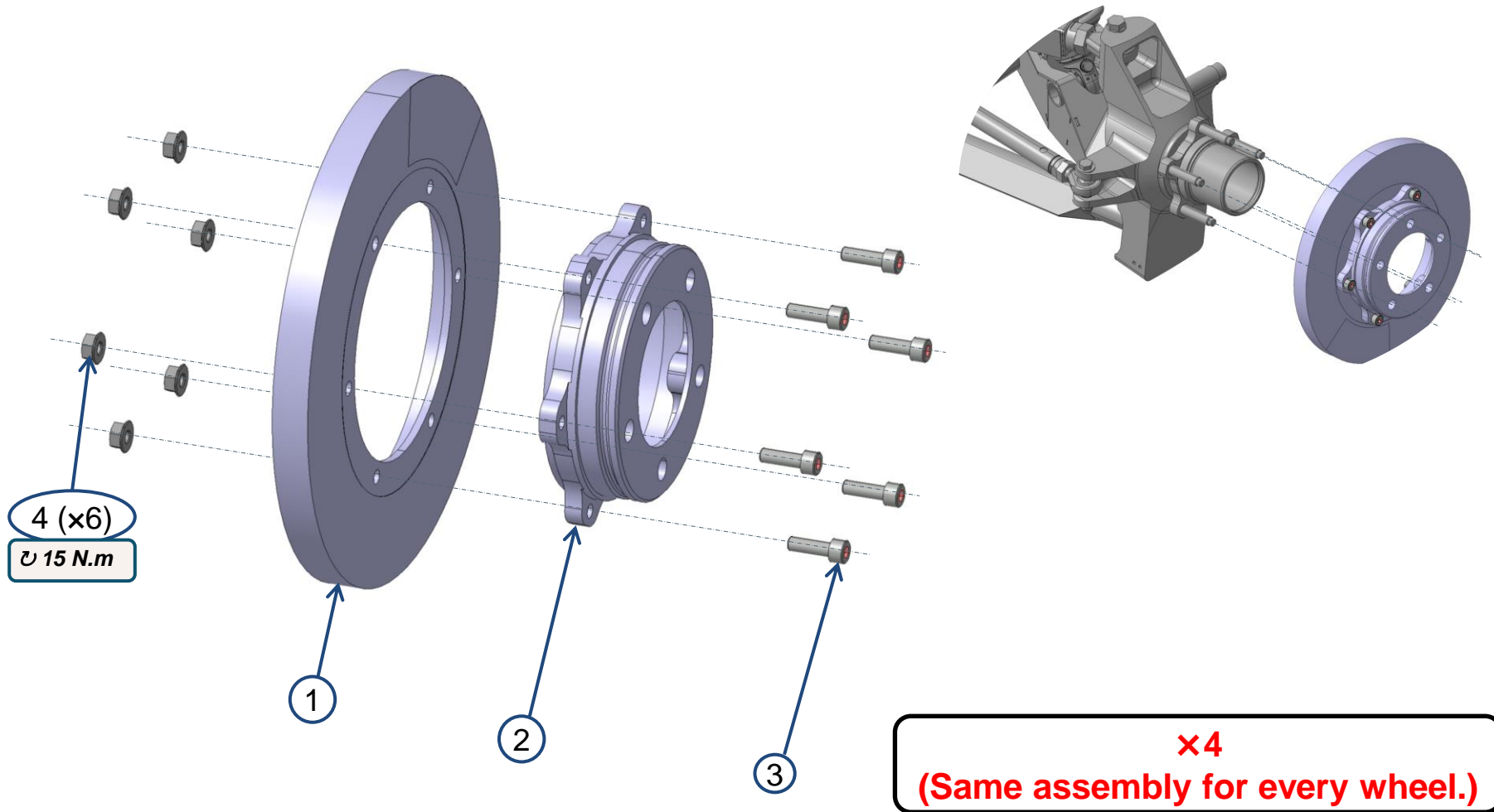

No.	Ref.	Name	Qty.
1	4012582	COP VENTILATED BRAKE DISC 11"X0.81"	1
2	4012768	DRP - BRAKES BOWL	1
3	4000965	SUP-HEXAGONAL SOCKET CAP SCREW ISO 4762 M8X25-25 P125 CL12.9 A B	6
4	4014322	SUP-LOCKNUT WITH FLANGE - M8X1.25 - SIMMONDS	6

# 11.3.1 BRAKES – Calipers – Front Right & Left

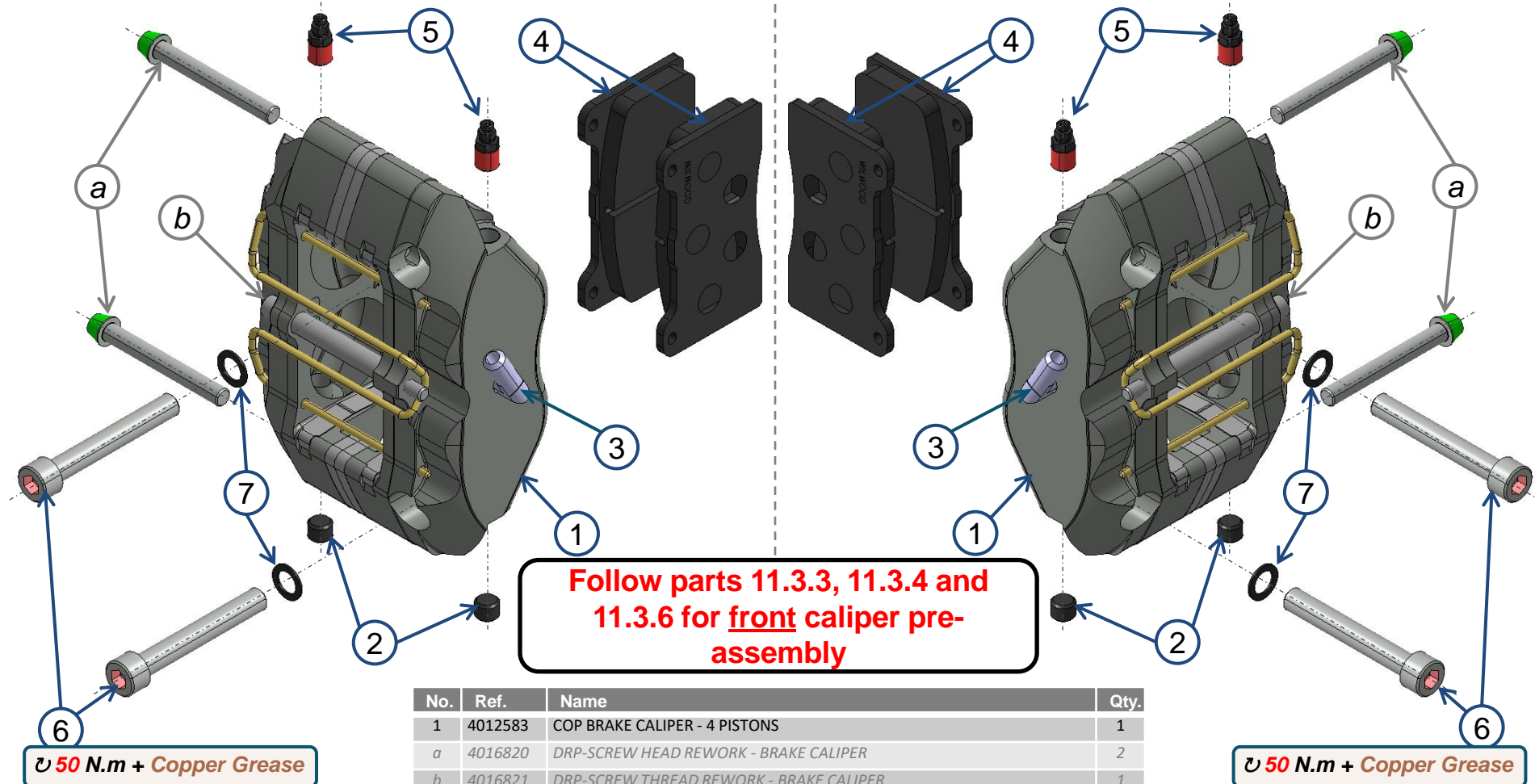

No.	Ref.	Name	Qty.
1	4012583	COP BRAKE CALIPER - 4 PISTONS	1
a	4016820	DRP-SCREW HEAD REWORK - BRAKE CALIPER	2
b	4016821	DRP-SCREW THREAD REWORK - BRAKE CALIPER	1
2	4013166	COP-PLUG FOR CALIPER WILWOOD	2
3	4012811	COP-FITTING M/M 90° 1/8-27 NPT - JIC 3/8-24	1
4	4012584	BRAKE PADS	2
5	4014095	COP-KIT BLEED SCREW	2
6	4000999	SUP-HEXAGONAL SOCKET CAP SCREW ISO 4762 M10X70-32 P150 CL12.9 A B	2
7	4013576	COP-WASHER SCHNORR M10	2



## 11.3.2 BRAKES – Calipers – Rear Right & Left

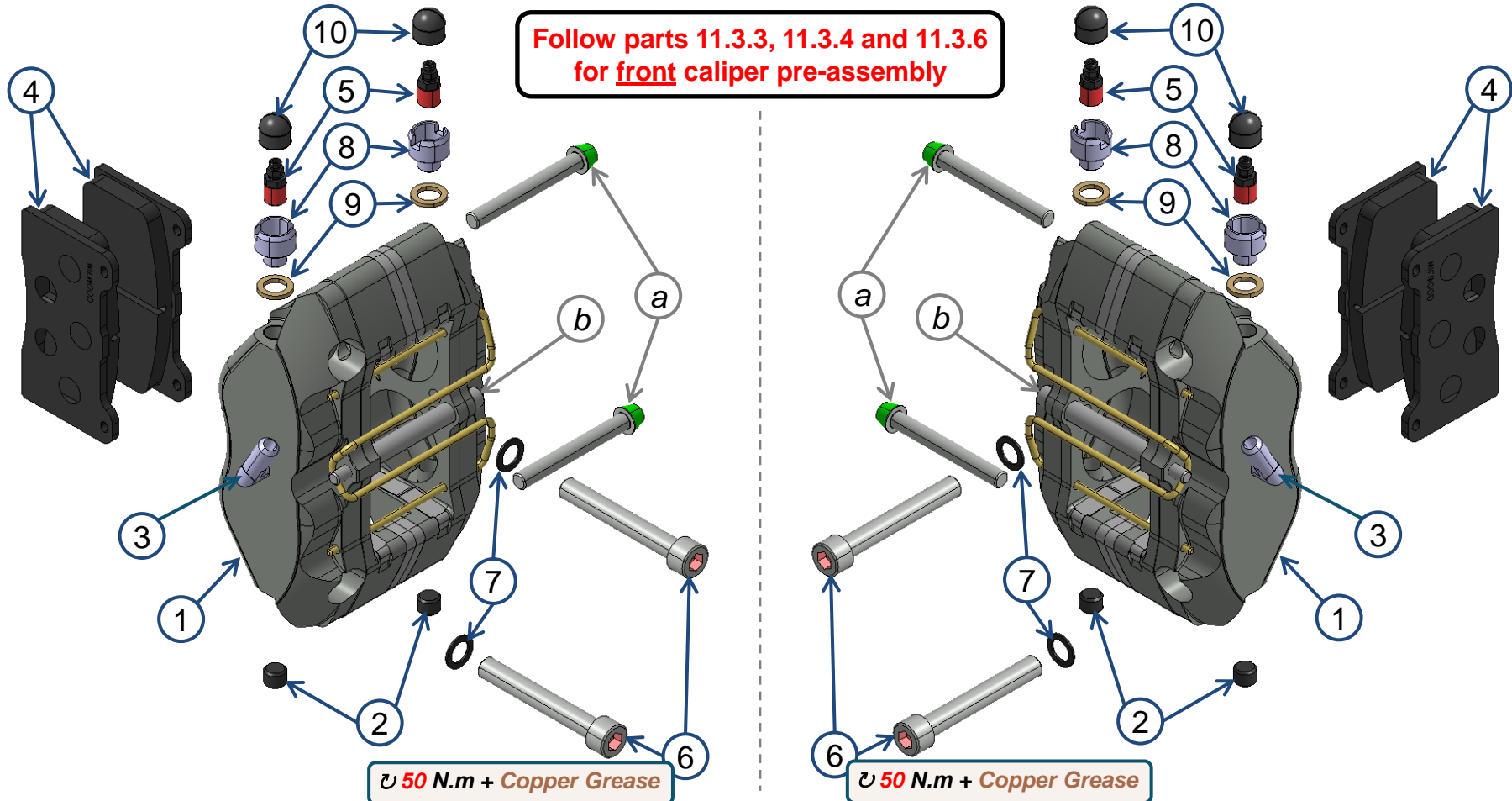

No.	Ref.	Name	Qty.
1	4012583	COP BRAKE CALIPER - 4 PISTONS	1
a	4016820	DRP-SCREW HEAD REWORK - BRAKE CALIPER	2
b	4016821	DRP-SCREW THREAD REWORK - BRAKE CALIPER	1
2	4013166	COP-PLUG FOR CALIPER WILWOOD	2
3	4012811	COP-FITTING M/M 90°1/8-27 NPT - JIC 3/8-24	1
4	4012584	BRAKE PADS	2

No.	Ref.	Name	Qty.
5	4014095	COP-KIT BLEED SCREW	2
6	4000999	SUP-HEXAGONAL SOCKET CAP SCREW ISO 4762 M10X70-32 P150 CL12.9 A B	2
7	4013576	COP-WASHER SCHNORR M10	2
8	4014018	DRP-CONNECTOR BLEED SCREW PROTECTION	2
9	4014090	COP-WASHER COPPER 10.5X16X2	2
10	4018120	DRP - COPONENT REWORK PLUG 11.1/25.4 EPDM BLACK L7MM	2

# 11.3.3 BRAKES – Calipers – Pre-Assembly (Font & Rear, Left & Right)

## TO DO List :

❑ 1) Remove the top, middle and bottom screws from the caliper.

❑ 2) Redrill the caliper fixing holes for M10 screws (10,5 mm)

❑ 4) Rework middle screw by following the [4016821] rework plan (remove part of the screw thread)

❑ 5) Rework the head of the top and bottom screws by following the [4016820] rework plan (make screw head conic to allow space for the bleed screw protection)

❑ 6) Reassemble the caliper using the reworked screws  
→ *Use Loctite 271 !*

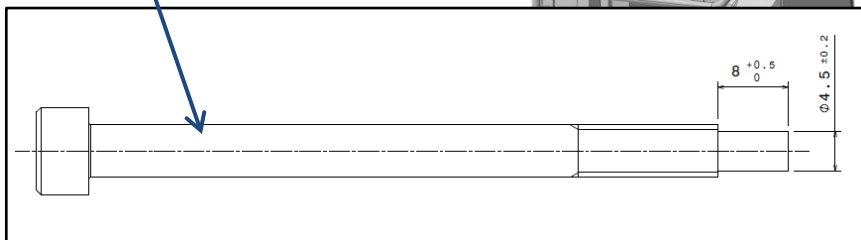
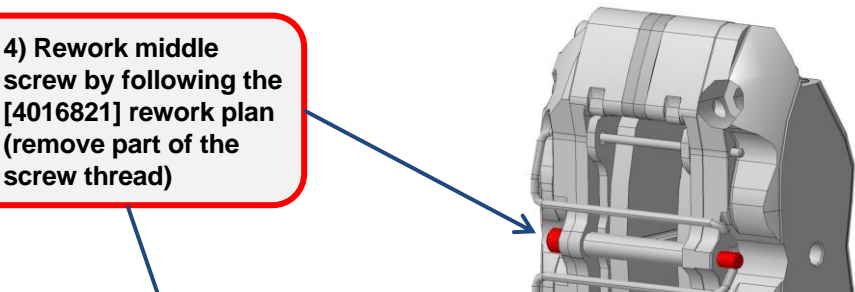
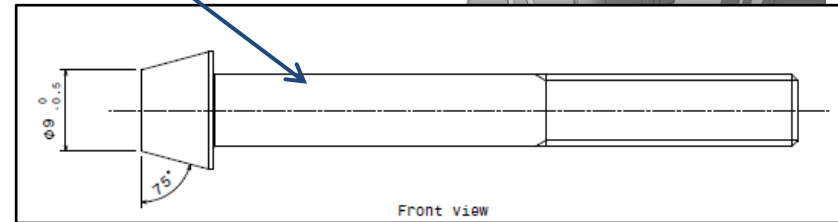
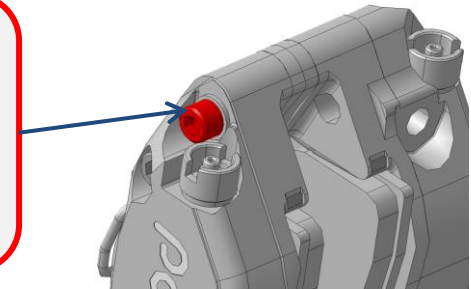
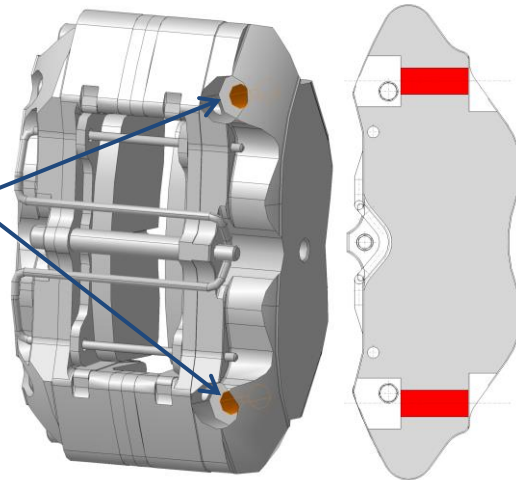

# 11.3.4 BRAKES – Calipers – Pre-Assembly Front (Left & Right)



**FRONT LEFT**

**FRONT RIGHT**



7) Keep upper bleed screw included in brake caliper

8) Replace bottom bleed screws with plugs [4013166]

9) Identify each caliper by marking it



# 11.3.5 BRAKES – Calipers – Pre-Assembly Rear (Left & Right)



**REAR LEFT**

**REAR RIGHT**

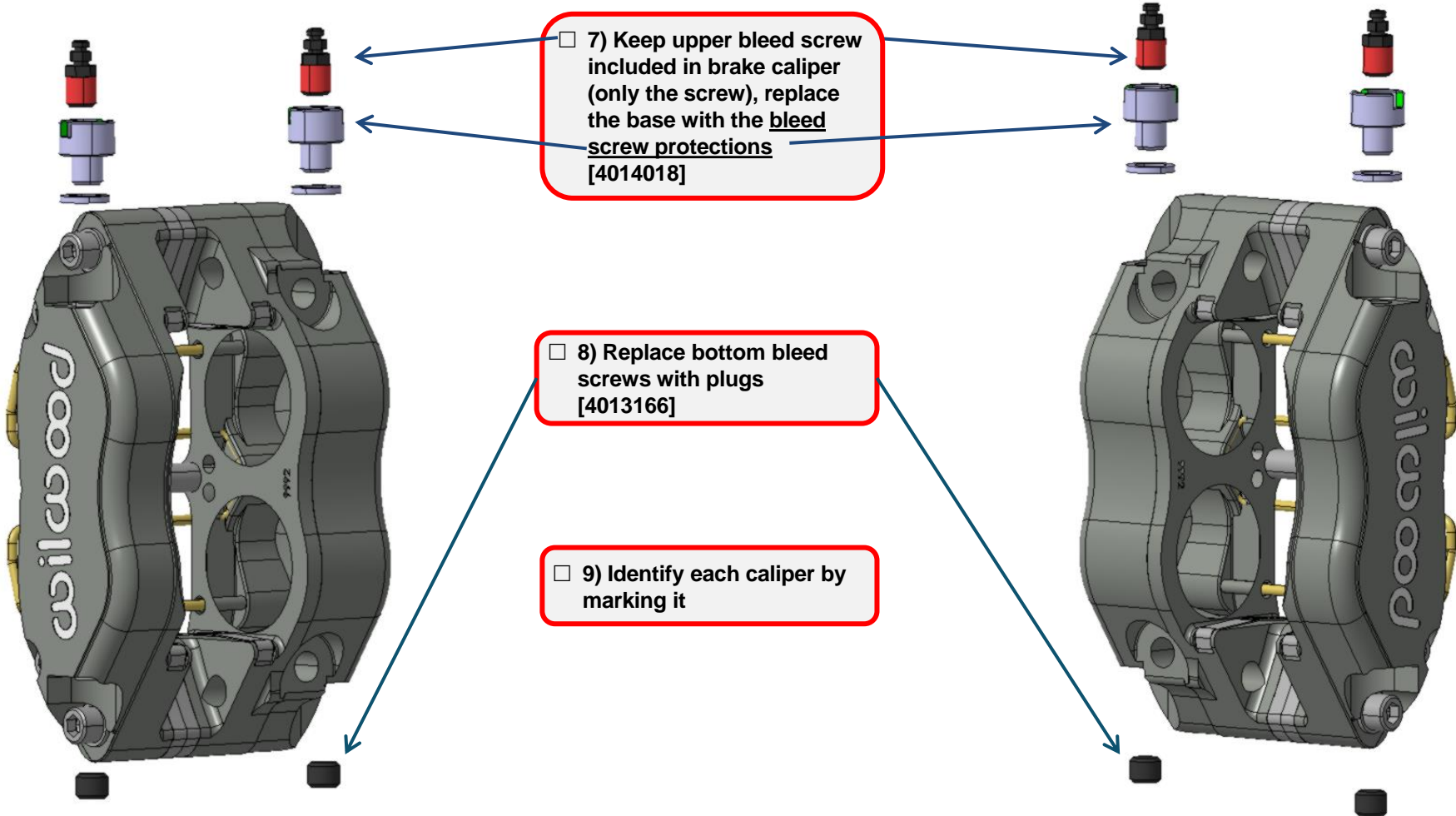

7) Keep upper bleed screw included in brake caliper (only the screw), replace the base with the bleed screw protections [4014018]

8) Replace bottom bleed screws with plugs [4013166]

9) Identify each caliper by marking it

## 11.3.6 BRAKES – Calipers – Pre-Assembly (Front & Rear, Left & Right)



**FRONT LEFT**

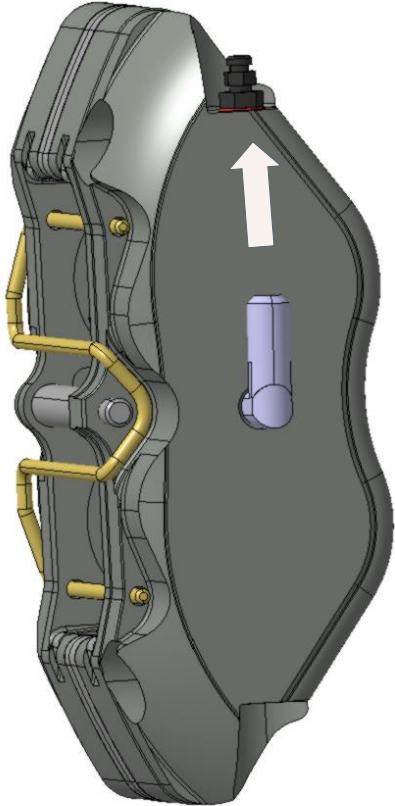

**FRONT RIGHT**

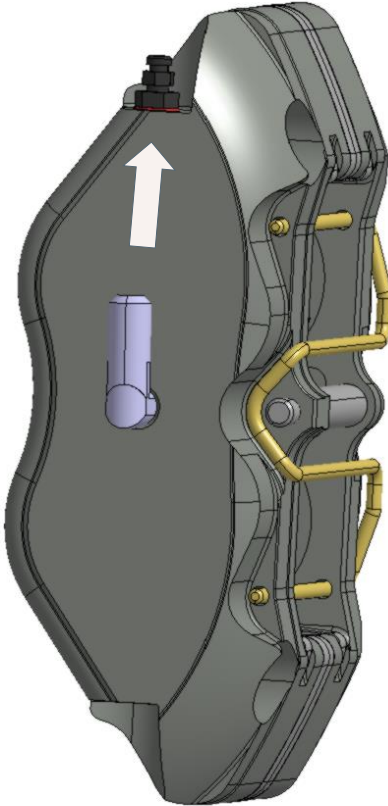

**REAR LEFT**

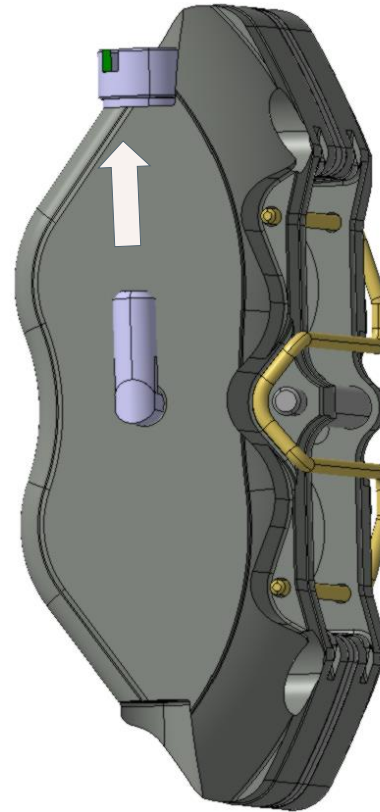

**REAR RIGHT**

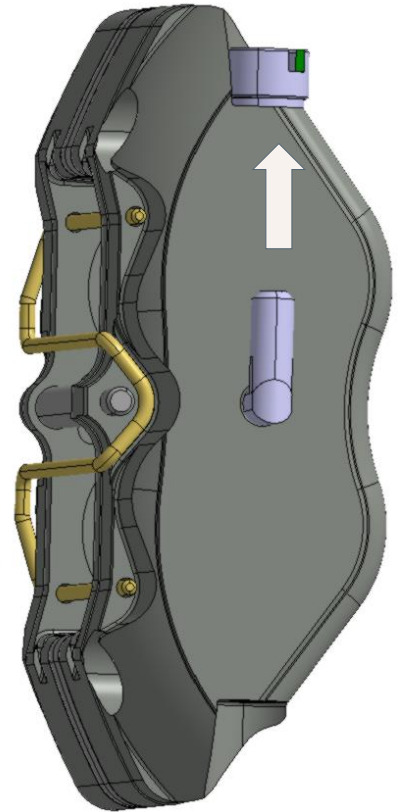

- 10) Add the 90° fitting. It has to be pointed towards the calliper's upper bleed screws

# 11.4.1 BRAKES – Braking circuit

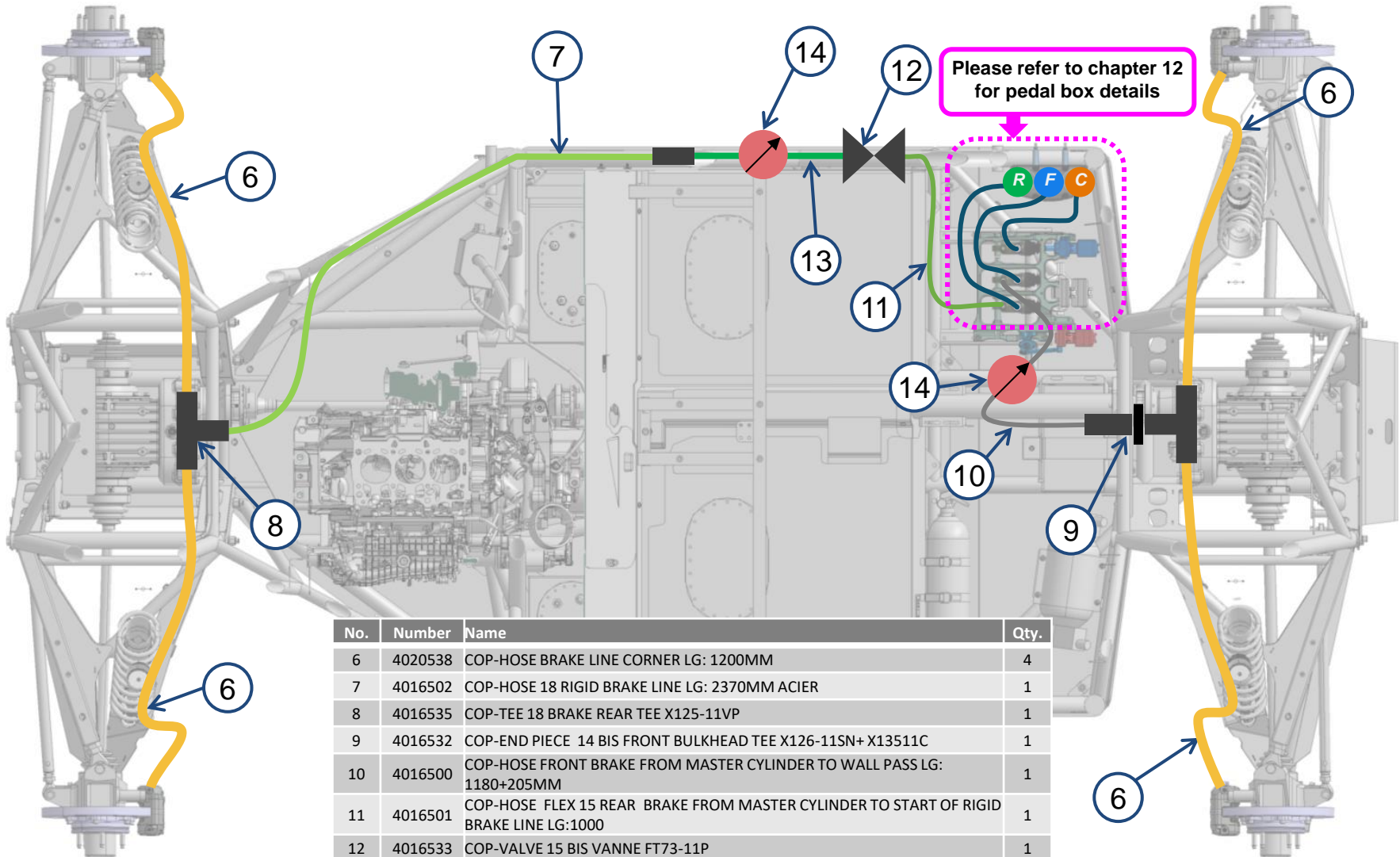

No.	Number	Name	Qty.
6	4020538	COP-HOSE BRAKE LINE CORNER LG: 1200MM	4
7	4016502	COP-HOSE 18 RIGID BRAKE LINE LG: 2370MM ACIER	1
8	4016535	COP-TEE 18 BRAKE REAR TEE X125-11VP	1
9	4016532	COP-END PIECE 14 BIS FRONT BULKHEAD TEE X126-11SN+ X13511C	1
10	4016500	COP-HOSE FRONT BRAKE FROM MASTER CYLINDER TO WALL PASS LG: 1180+205MM	1
11	4016501	COP-HOSE FLEX 15 REAR BRAKE FROM MASTER CYLINDER TO START OF RIGID BRAKE LINE LG:1000	1
12	4016533	COP-VALVE 15 BIS VANNE FT73-11P	1
13	4016534	COP-HOSE FLEX 16-17 BRAKE REAR CAPTEUR 550+ 90MM	1
14	4016597	SASS-HARNES FRONT AND REAR BRAKES PRESSURE WIRING	2

# 11.4.2 BRAKES – Braking circuit

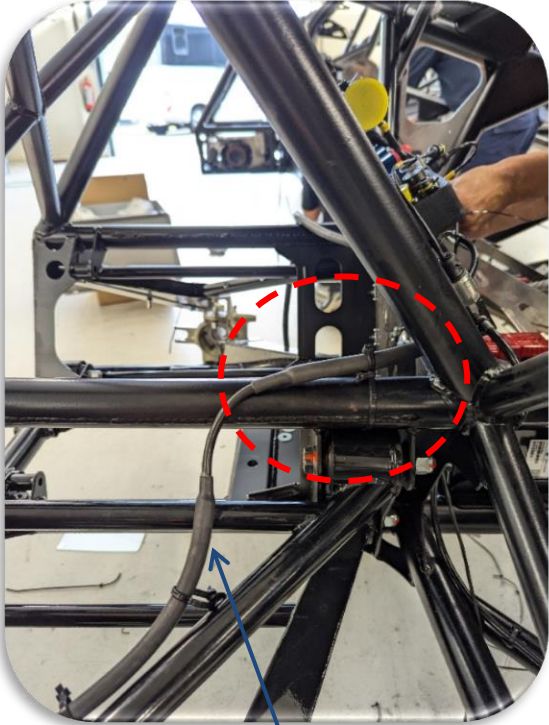

6

**Brake line have to pass UP of the chassis tube**

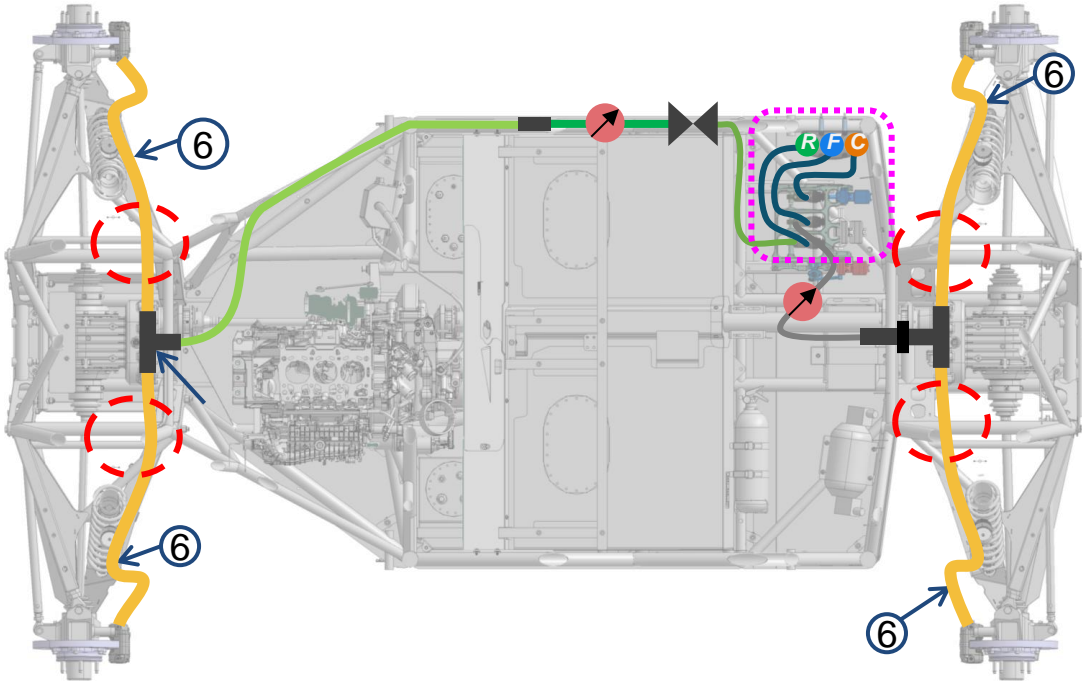

No.	Number	Name	Qty.
6	4020538	COP-HOSE BRAKE LINE CORNER LG: 1200MM	4

## 11.4.3 BRAKES – Braking circuit

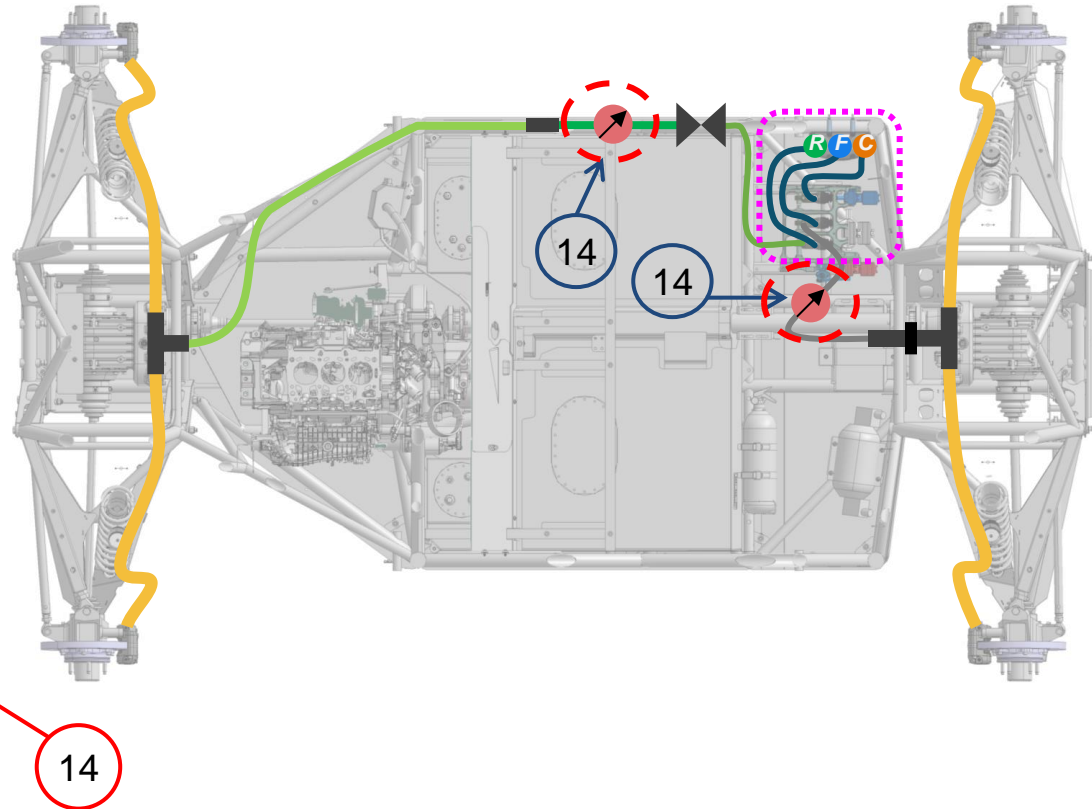
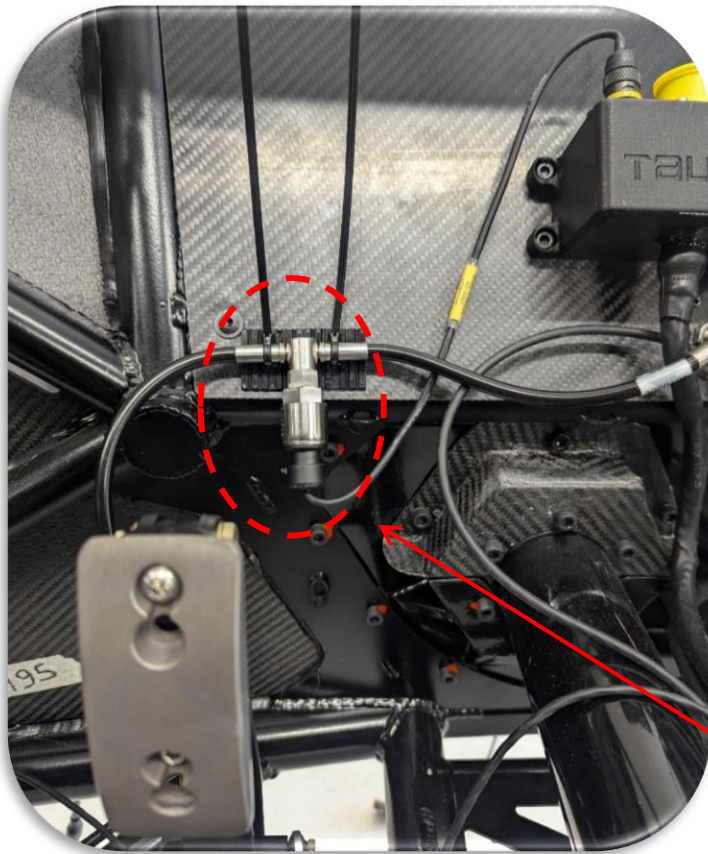

**Put the sensors as vertical as possible Upside down to avoid air bubble stuck.**

No.	Number	Name	Qty.
14	4016597	SASS-HARNESS FRONT AND REAR BRAKES PRESSURE WIRING	2



## 11.4.4 BRAKES – Braking circuit

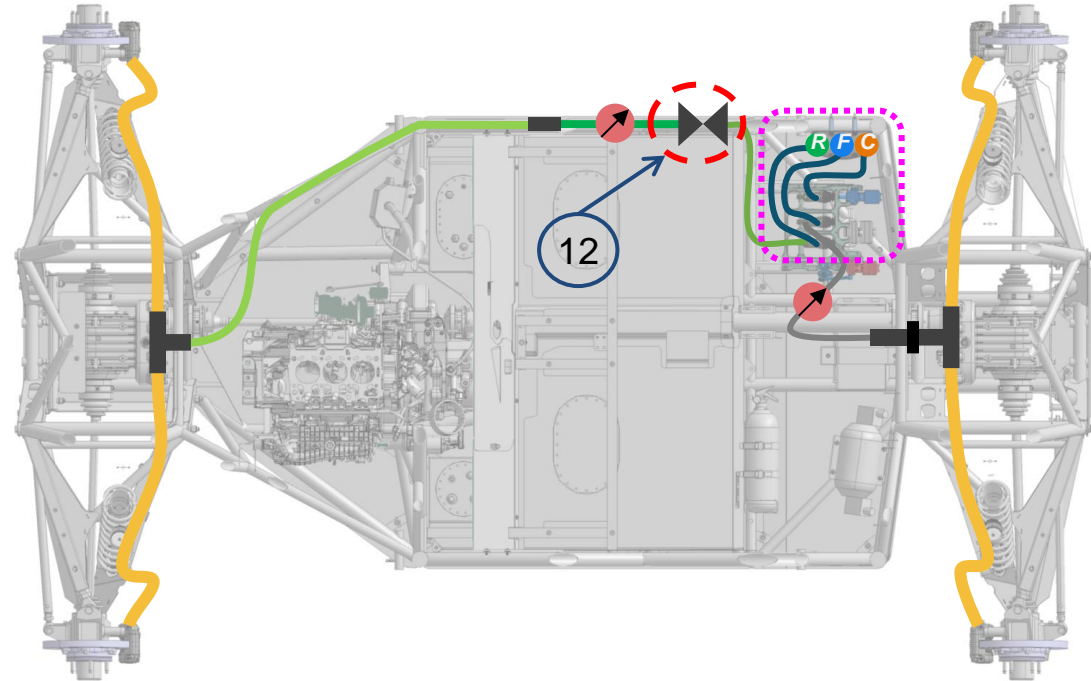
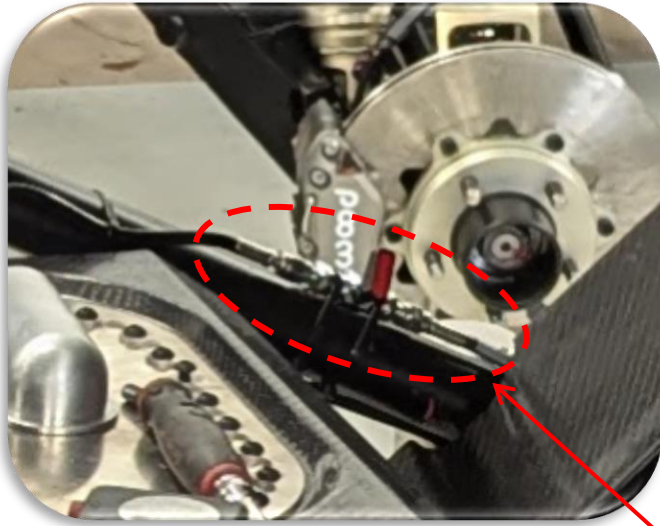

**Brake valve must be on top of the tube**

12

No.	Number	Name	Qty.
12	4016533	COP-VALVE 15 BIS VANNE FT73-11P	1

## Section 12

## STEERING

## 12. STEERING – TOOLS NEEDED

---



### ■ Specific tool needed

- ▶ **Torque wrench : 5 → 25 Nm**
- ▶ **1" (25,4mm) Manual tap tool**



### ■ Specific sealing needed:

# 12.1 STEERING – Overview

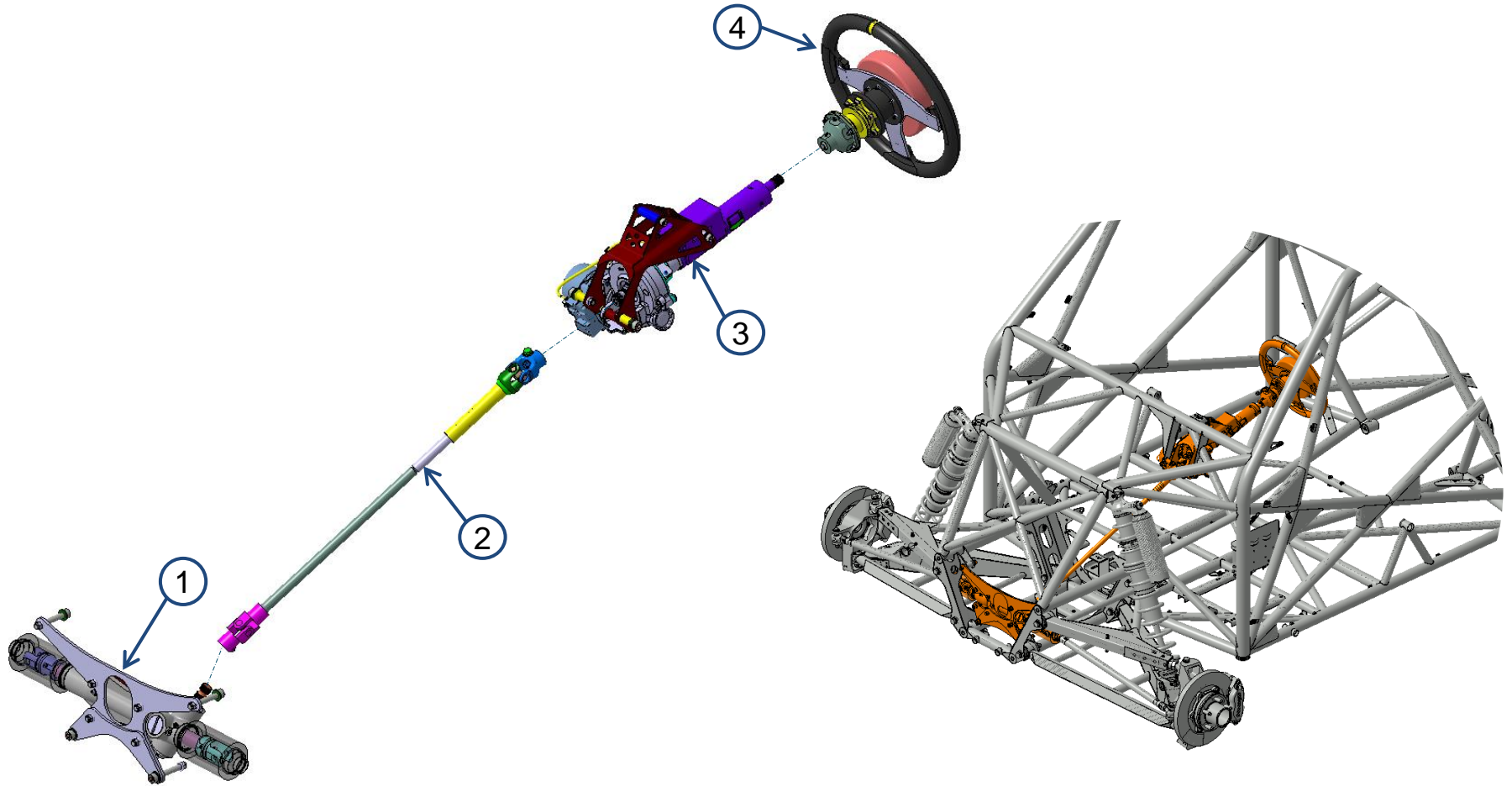

No.	Ref.	Name	Qty.
1	4012883	SASS - RACK STEERING ASSEMBLY	1
2	4017095	SASS - COLUMN RETRACTABLE WELDED STEERING DACIA	1
3	4017109	SASS - POWER STEERING EQUIPPED - DACIA	1
4	4017049	SASS - STEERING WHEEL EQUIPPED	1

# 12.2.1 STEERING – Rack Steering Assembly – Rack

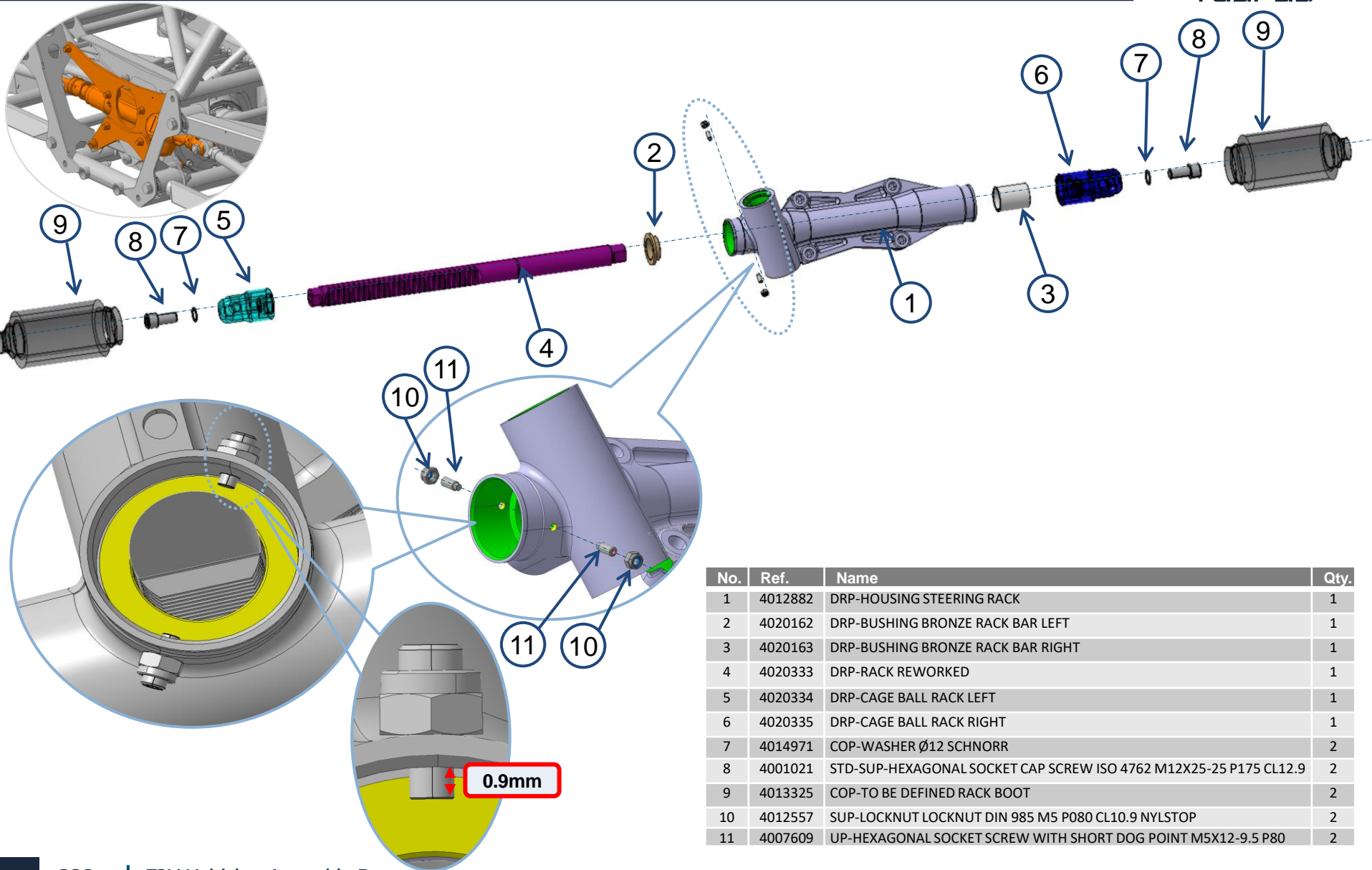

No.	Ref.	Name	Qty.
1	4012882	DRP-HOUSING STEERING RACK	1
2	4020162	DRP-BUSHING BRONZE RACK BAR LEFT	1
3	4020163	DRP-BUSHING BRONZE RACK BAR RIGHT	1
4	4020333	DRP-RACK REWORKED	1
5	4020334	DRP-CAGE BALL RACK LEFT	1
6	4020335	DRP-CAGE BALL RACK RIGHT	1
7	4014971	COP-WASHER Ø12 SCHNORR	2
8	4001021	STD-SUP-HEXAGONAL SOCKET CAP SCREW ISO 4762 M12X25-25 P175 CL12.9	2
9	4013325	COP-TO BE DEFINED RACK BOOT	2
10	4012557	SUP-LOCKNUT LOCKNUT DIN 985 M5 P080 CL10.9 NYLSTOP	2
11	4007609	UP-HEXAGONAL SOCKET SCREW WITH SHORT DOG POINT M5X12-9.5 P80	2

# 12.2.5 STEERING – Rack Steering Assembly – Rack

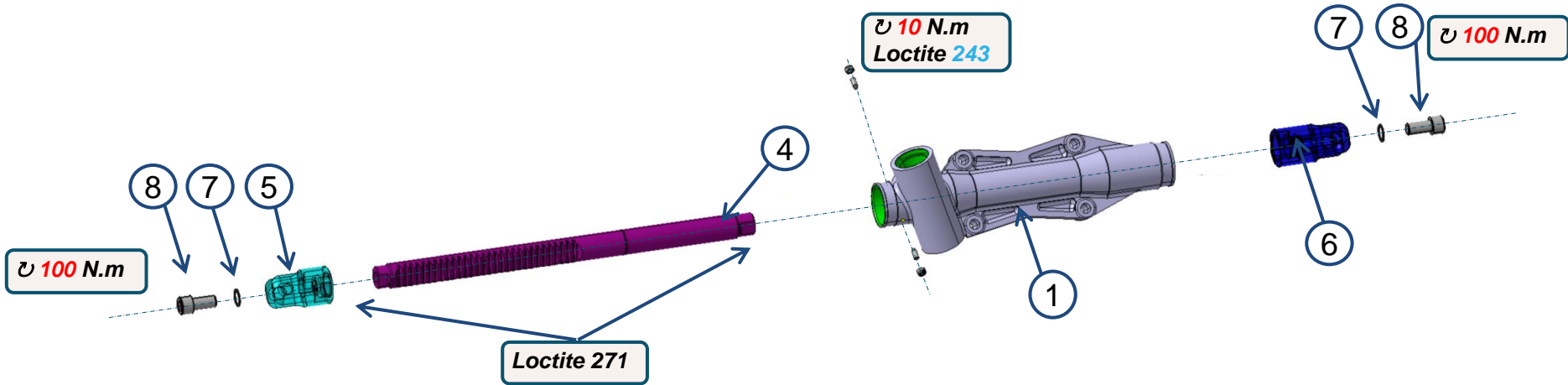

**Remove the 57mm spacer,**

- Assemble the rack
- Add Loctite 271 on the bolt each side
- Apply 100 Nm on Ball cage bolt (#8)

No.	Ref.	Name	Qty.
1	4012882	DRP-HOUSING STEERING RACK	1
2	4020162	DRP-BUSHING BRONZE RACK BAR LEFT	1
3	4020163	DRP-BUSHING BRONZE RACK BAR RIGHT	1
4	4020333	DRP-RACK REWORKED	1
5	4020334	DRP-CAGE BALL RACK LEFT	1
6	4020335	DRP-CAGE BALL RACK RIGHT	1
7	4014971	COP-WASHER Ø12 SCHNORR	2
8	4001021	STD-SUP-HEXAGONAL SOCKET CAP SCREW ISO 4762 M12X25-25 P175 CL12.9	2
9	4013325	COP-TO BE DEFINED RACK BOOT	2
10	4012557	SUP-LOCKNUT LOCKNUT DIN 985 M5 P080 CL10.9 NYLSTOP	2
11	4007609	UP-HEXAGONAL SOCKET SCREW WITH SHORT DOG POINT M5X12-9.5 P80	2

# 12.2.6 STEERING – Rack Steering Assembly – Rack



Lock the small bushing on rack side

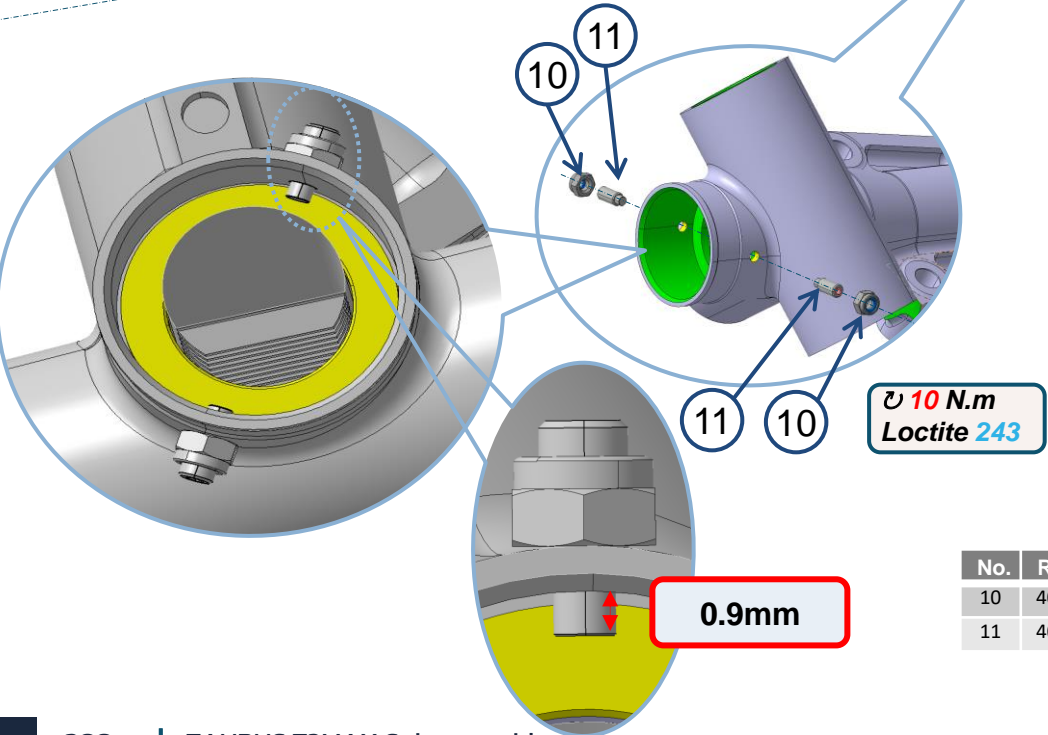
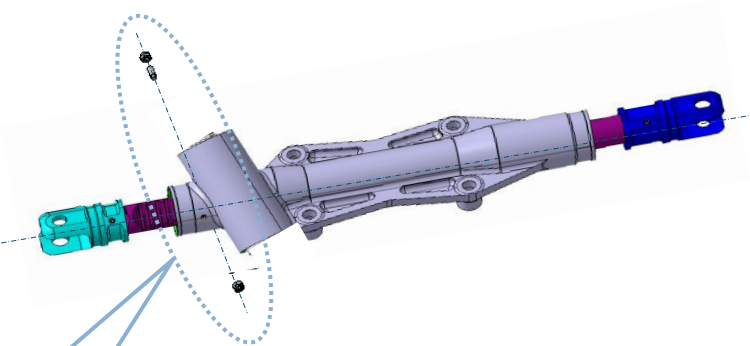

No.	Ref.	Name	Qty.
10	4012557	SUP-LOCKNUT LOCKNUT DIN 985 M5 P080 CL10.9 NYLSTOP	2
11	4007609	UP-HEXAGONAL SOCKET SCREW WITH SHORT DOG POINT M5X12-9.5 P80	2

# 12.2.7 STEERING – Rack Steering Assembly – Pinion

- 1) **Screw rack yoke 8 until eliminate the spinning clearance**
- 2) **Then unscrew rack yoke 8 until you obtain a little spinning clearance**

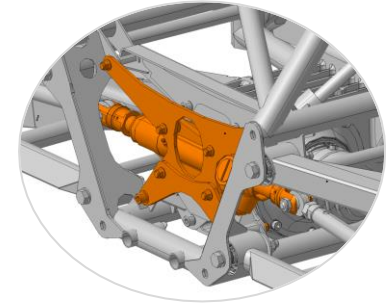
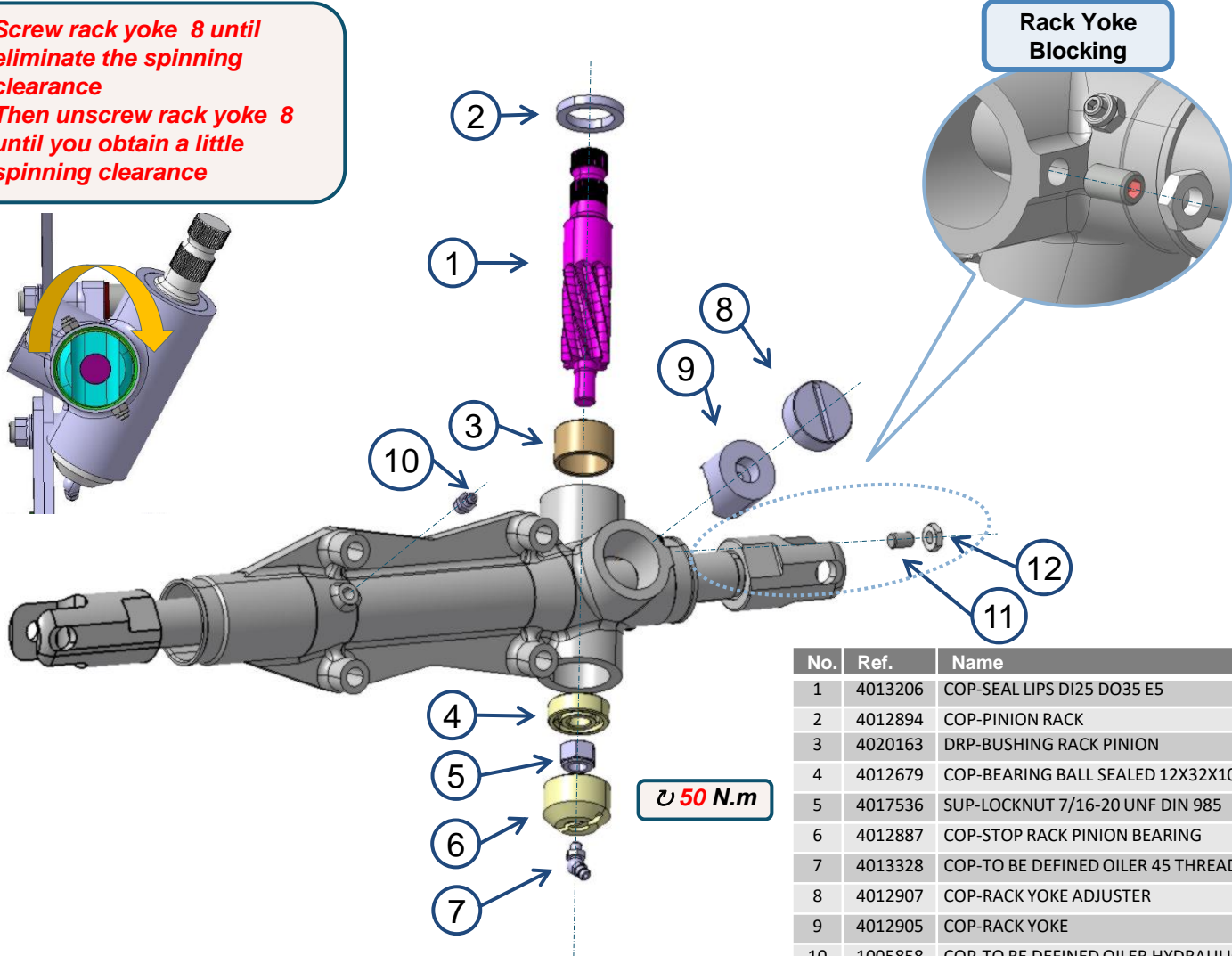
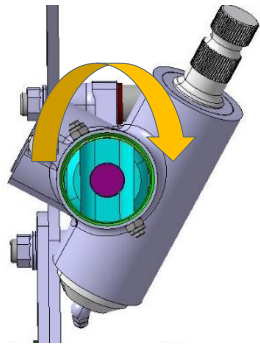

**50 N.m**

No.	Ref.	Name	Qty.
1	4013206	COP-SEAL LIPS DI25 DO35 E5	1
2	4012894	COP-PINION RACK	1
3	4020163	DRP-BUSHING RACK PINION	1
4	4012679	COP-BEARING BALL SEALED 12X32X10	1
5	4017536	SUP-LOCKNUT 7/16-20 UNF DIN 985	1
6	4012887	COP-STOP RACK PINION BEARING	1
7	4013328	COP-TO BE DEFINED OILER 45 THREAD TBD	1
8	4012907	COP-RACK YOKE ADJUSTER	1
9	4012905	COP-RACK YOKE	1
10	1005858	COP-TO BE DEFINED OILER HYDRAULIC FORM A M8X1.25	1
11	4006236	SUP-HEXAGONAL SOCKET SCREW WITH FLAT POINT M8X12-12 P125	1
12	4008724	SUP-JAM NUT HM M8X4 P125 CL05	1



# 12.2.8 STEERING – Rack Steering Assembly – Bracket

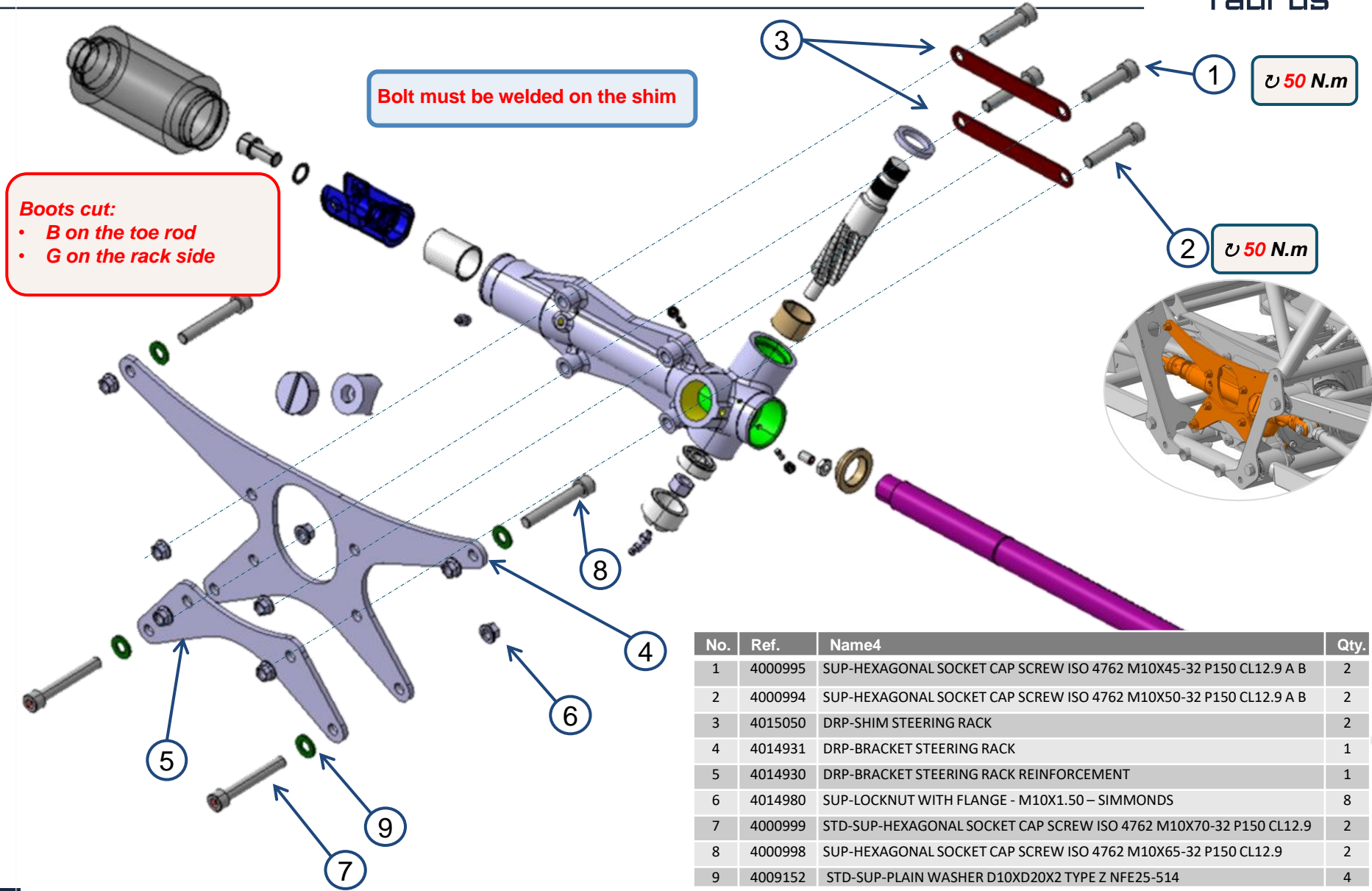

No.	Ref.	Name4	Qty.
1	4000995	SUP-HEXAGONAL SOCKET CAP SCREW ISO 4762 M10X45-32 P150 CL12.9 A B	2
2	4000994	SUP-HEXAGONAL SOCKET CAP SCREW ISO 4762 M10X50-32 P150 CL12.9 A B	2
3	4015050	DRP-SHIM STEERING RACK	2
4	4014931	DRP-BRACKET STEERING RACK	1
5	4014930	DRP-BRACKET STEERING RACK REINFORCEMENT	1
6	4014980	SUP-LOCKNUT WITH FLANGE - M10X1.50 – SIMMONDS	8
7	4000999	STD-SUP-HEXAGONAL SOCKET CAP SCREW ISO 4762 M10X70-32 P150 CL12.9	2
8	4000998	SUP-HEXAGONAL SOCKET CAP SCREW ISO 4762 M10X65-32 P150 CL12.9	2
9	4009152	STD-SUP-PLAIN WASHER D10XD20X2 TYPE Z NFE25-514	4

# 12.2.9 STEERING – Rack Steering Assembly – Bracket On Frame

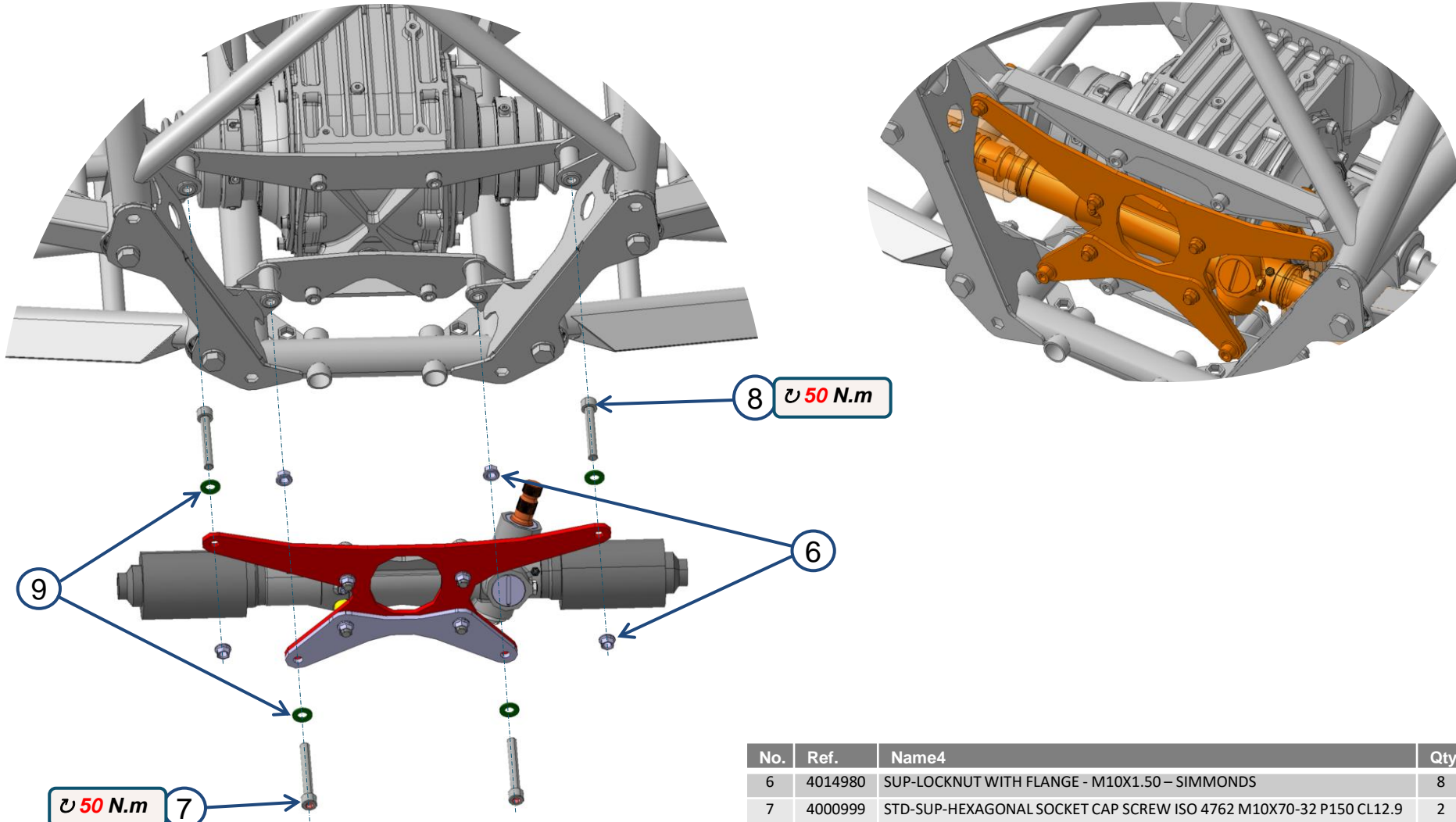

No.	Ref.	Name4	Qty.
6	4014980	SUP-LOCKNUT WITH FLANGE - M10X1.50 – SIMMONDS	8
7	4000999	STD-SUP-HEXAGONAL SOCKET CAP SCREW ISO 4762 M10X70-32 P150 CL12.9	2
8	4000998	SUP-HEXAGONAL SOCKET CAP SCREW ISO 4762 M10X65-32 P150 CL12.9	2
9	4009152	STD-SUP-PLAIN WASHER D10XD20X2 TYPE Z NFE25-514	4

## 12.3 STEERING – Column

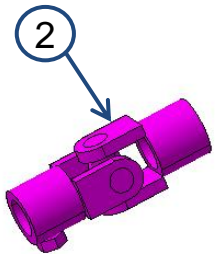
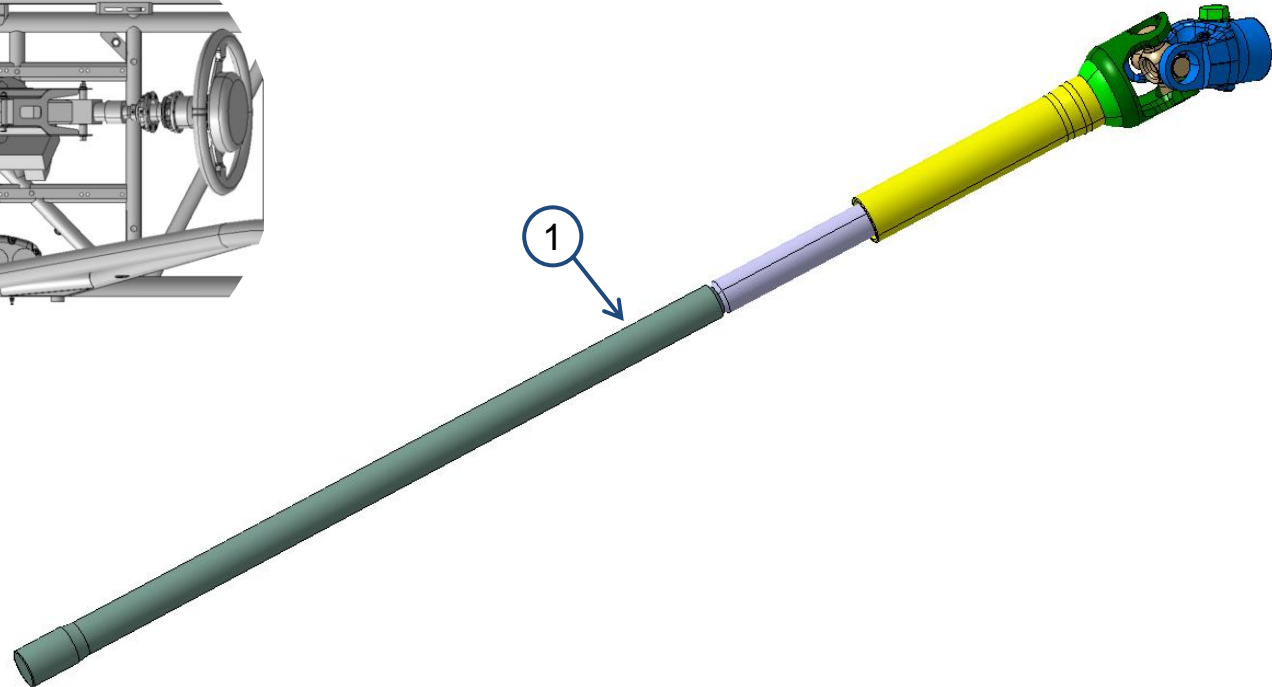
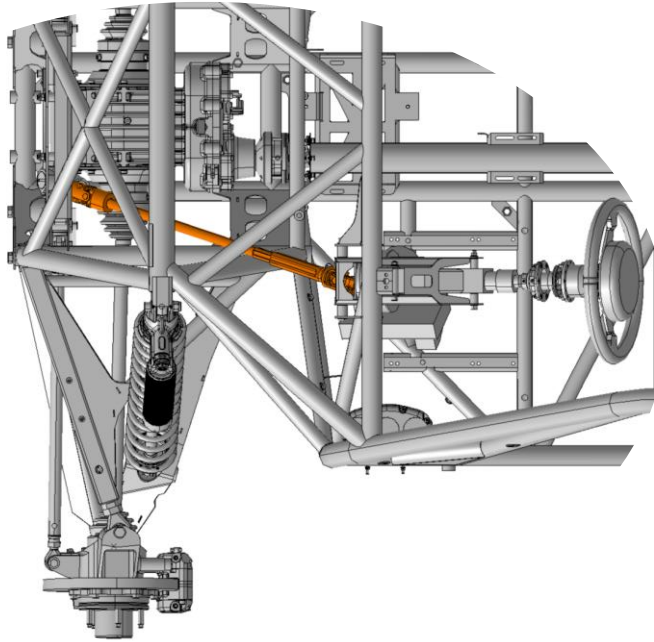

No.	Ref.	Name	Qty.
1	4017093	DRP-EXTENSION STEERING COLUMN DACIA	1
2	4013002	COP-BALL JOINT SWEET OEM	1

## 12.4.4 STEERING – Unit Power Steering – Hardware

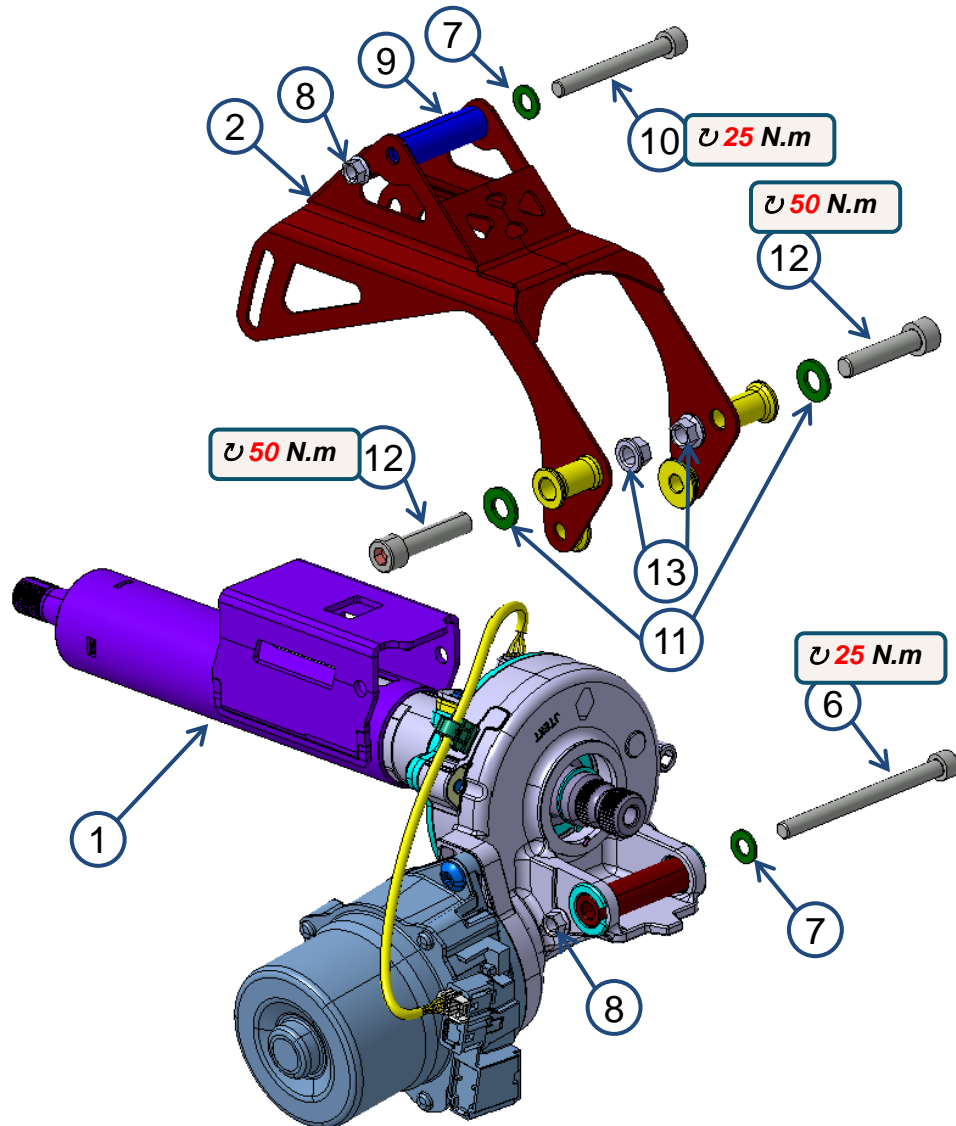
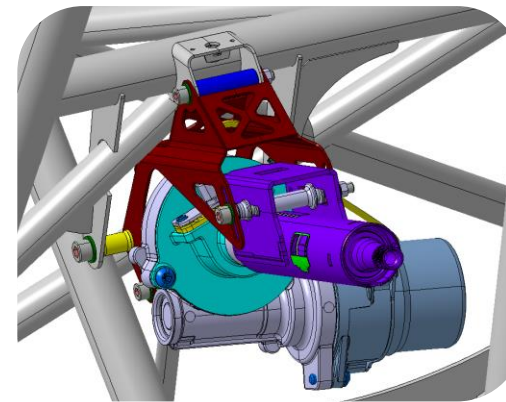
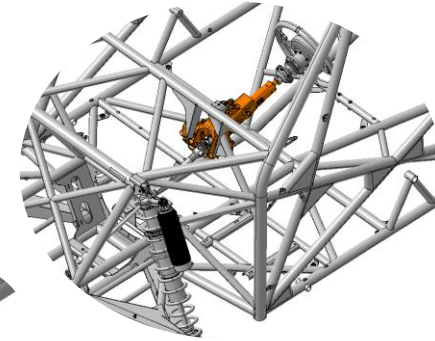

No.	Ref.	Number-Version-Name	Qty.
1	4016843	MCE-DRP-COMPONENT POWER STEERING DACIA - CUSTOM T3M	1
2	4017069	MCE-SASS-BRACKET POWER STEERING WELDED	1
6	4000978	STD-SUP-HEXAGONAL SOCKET CAP SCREW	1
7	4009151	STD-SUP-PLAIN WASHER	2
8	4014322	MCE-SUP-LOCKNUT WITH FLANGE	2
9	4014354	MCE-DRP-SPACER	1
10	4000974	STD-SUP-HEXAGONAL SOCKET CAP SCREW	1
11	4009152	STD-SUP-PLAIN WASHER	2
12	4000994	STD-SUP-HEXAGONAL SOCKET CAP SCREW	2
13	4014980	MCE-SUP-LOCKNUT WITH FLANGE	2

## 12.4.5 STEERING – Unit Power Steering – Hardware

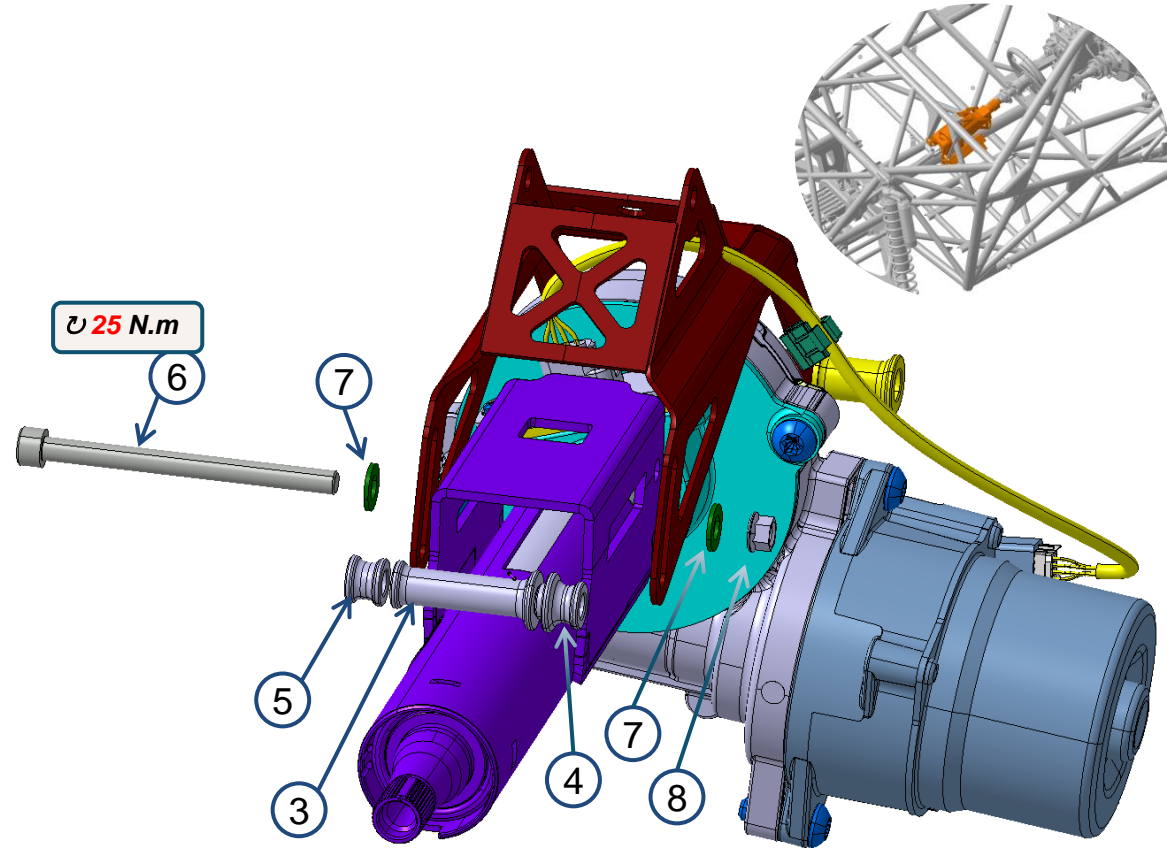
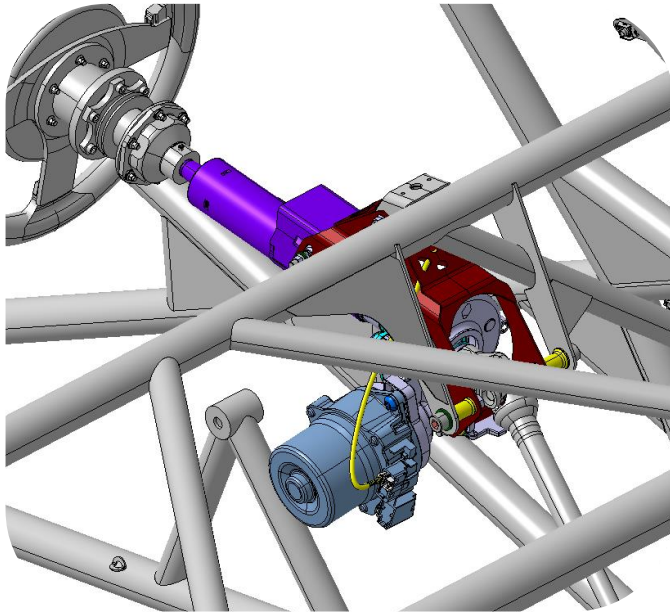

No.	Ref.	Name	Qty.
3	4017086	MCE-DRP-SPACER CENTRAL	1
4	4017081	MCE-DRP-SPACER RIGHT	1
5	4017072	MCE-DRP-SPACER LEFT	1
6	4000978	STD-SUP-HEXAGONAL SOCKET CAP SCREW	1
7	4009151	STD-SUP-PLAIN WASHER	2
8	4014322	MCE-SUP-LOCKNUT WITH FLANGE - SIMMONDS	1

# 12.5.1 STEERING – Steering Wheel – QR SPARCO

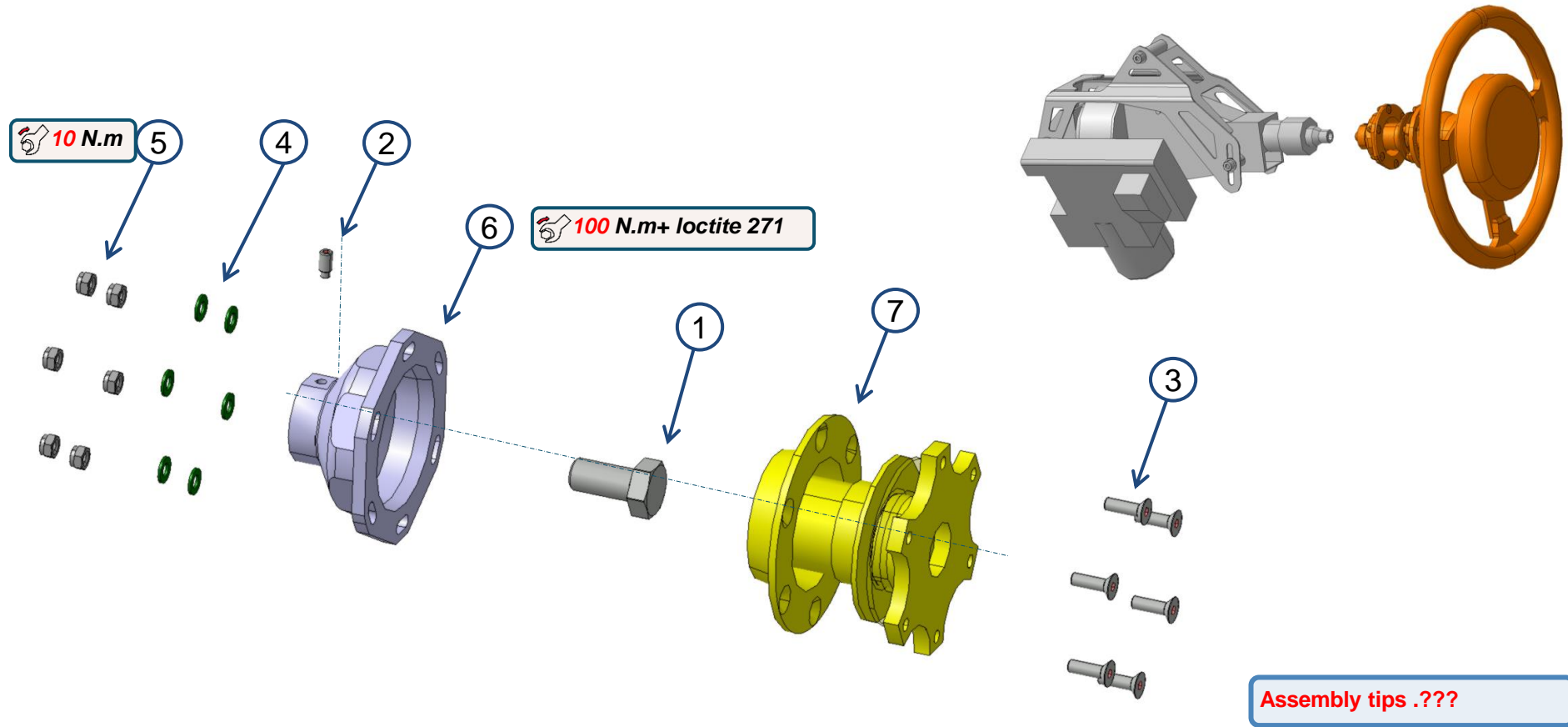

**Assembly tips .???**

No.	Ref.	Name	Qty.
1	4007076	COP - VIS DE FIXATION DAE RENAULT-ADAPTATEUR DAE	1
2	4007608	SUP-HEXAGONAL SOCKET SCREW WITH SHORT DOG POINT M5X10-7.5 P80 CL45H ISO4028 A B	1
3	4003375	SUP-HEXAGON SOCKET COUNTERSUNK HEAD CAP SCREW M5X16-13 P80 CL10.9 ISO10642 A B	6
4	4009149	SUP-PLAIN WASHER D5XD10X1 TYPE Z NFE25-514 A EZ	6
5	4012557	LOCKNUT DIN 985 M5 P080 CL10.9 NYLSTOP	6
6	4012831	DRP-ADAPTER STEERING WHEEL/STEERING SYSTEM	1
7	4012788	COP-RETRACTABLE HUB FIA - SPARCO	1

## 12.5.2 STEERING – Steering Wheel – QR SPARCO

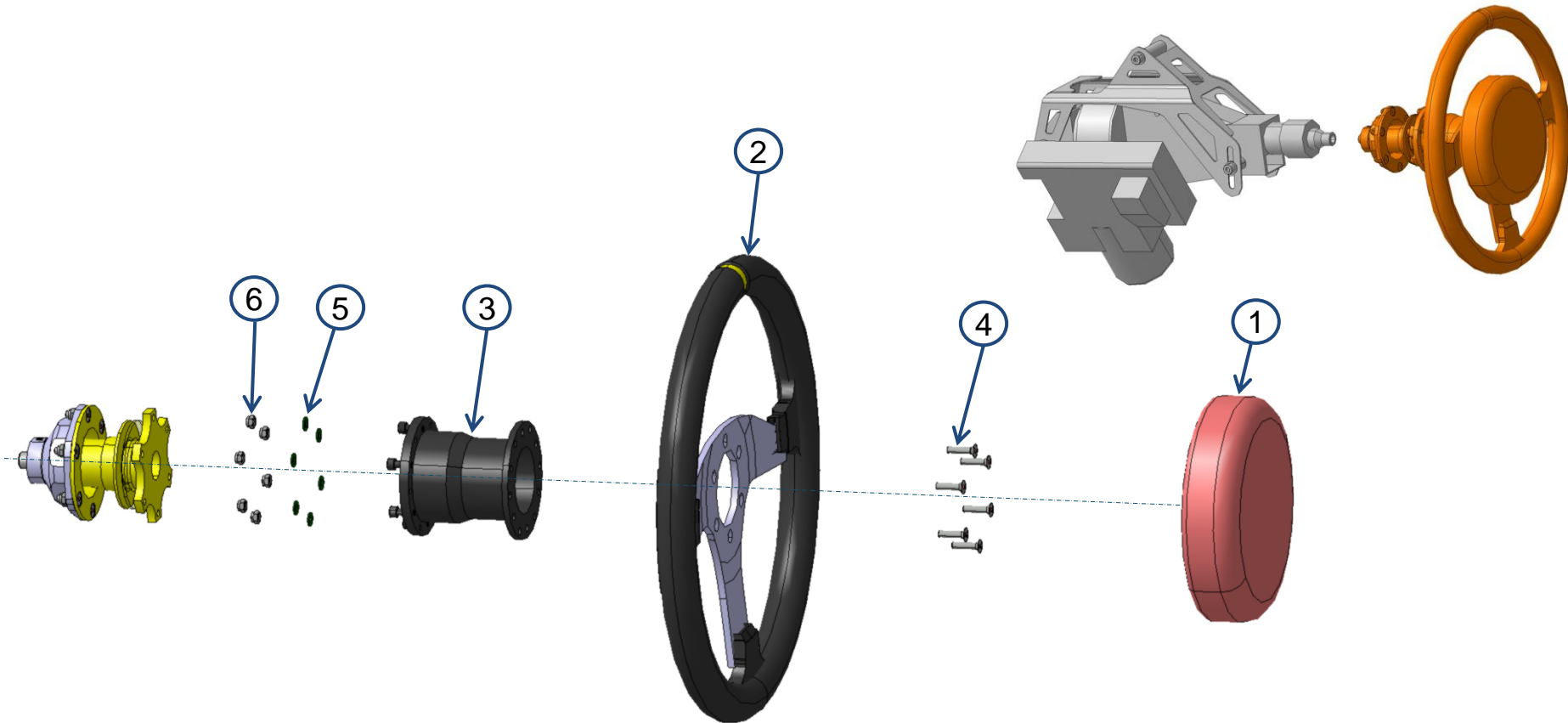

No.	Ref.	Name	Qty.
1	4013324	COP-STEERING WHEEL PROTECTION FIA SPARCO	1
2	4014822	COP - STEERING WHEEL R330 SUEDE – SPARCO	1
3	4014816	COP-SPACER STEERING WHEEL 80MM BG RACING	1
4	4003377	SUP-HEXAGON SOCKET COUNTERSUNK HEAD CAP SCREW M5X20-17 P80 CL10.9 ISO10642 A B	6
5	4009149	SUP-PLAIN WASHER D5XD10X1 TYPE Z NFE25-514 A EZ	6
6	4012557	LOCKNUT DIN 985 M5 P080 CL10.9 NYLSTOP	6

## 12.5.3 STEERING – Steering Wheel – QR Krontec

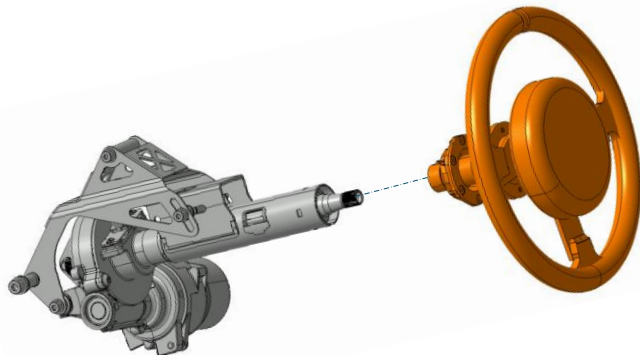
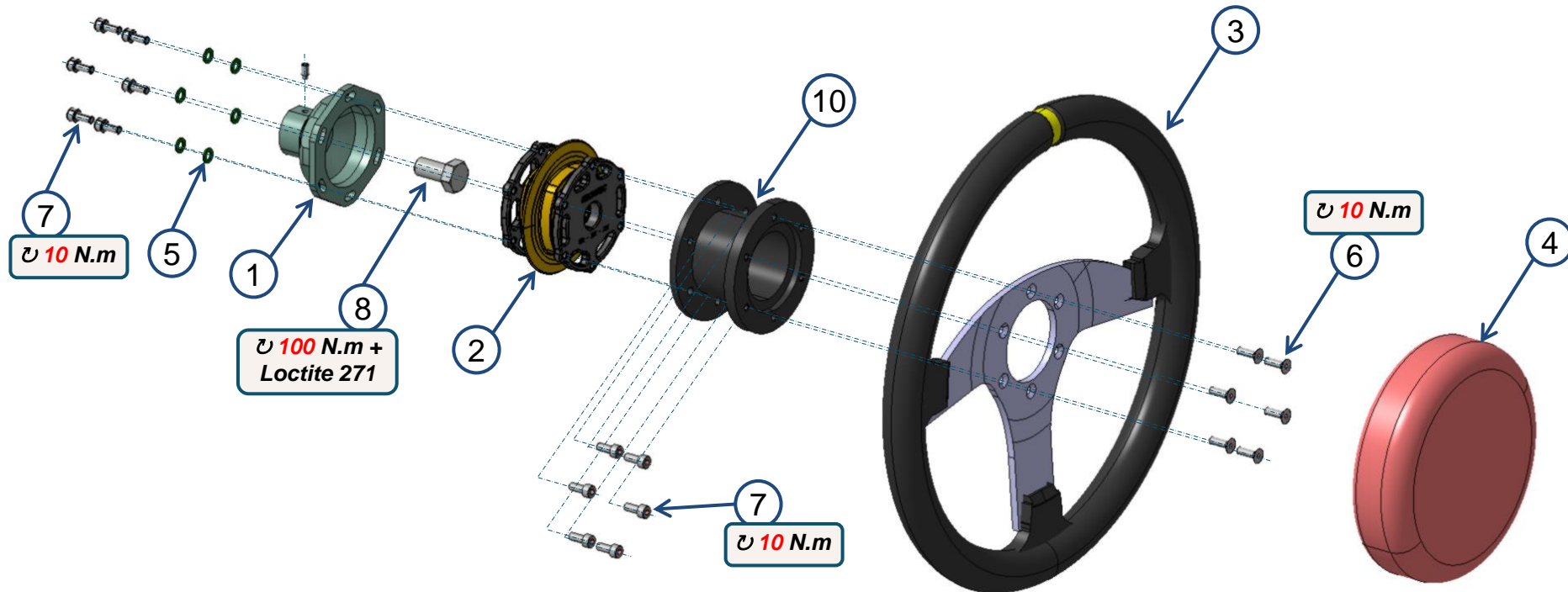

No.	Ref.	Name	Qty.
1	4017104	MCE-DRP-ADAPTER STEERING WHEEL TO POWER STEERING DACIA	1
2	4020995	MCE-COP-HUB QUICK RELEASE FOR STEERING WHEEL - KRONTEC	1
3	4014822	MCE-COP-TO BE DEFINED STEERING WHEEL R330 SUEDE - SPARCO	1
4	4013324	MCE-COP-TO BE DEFINED STEERING WHEEL PROTECTION FIA SPARCO	1
5	4009149	STD-SUP-PLAIN WASHER D5XD10X1 TYPE Z NFE25-514 A EZ	6
6	4003534	STD-SUP-HEXAGON SOCKET COUNTERSUNK HEAD CAP SCREW M5X16-13 P80 CL12.9 ISO10642 A B	6
7	4000906	STD-SUP-HEXAGONAL SOCKET CAP SCREW ISO 4762 M5X12-12 P80 CL12.9 A B	12
8	4007076	STD-SUP-HEXAGONAL HEAD SCREW M12X25-23 P175 CL10.9 ISO4017 A B	1
9	4007608	STD-SUP-HEXAGONAL SOCKET SCREW WITH SHORT DOG POINT M5X10-7.5 P80 CL45H ISO4028 A B	1
10	4014823	MCE-COP-TO BE DEFINED STEERING WHEEL SPACER L50MM - SPARCO	1



## 12.5.2 STEERING – Steering Wheel – Push Button Plate

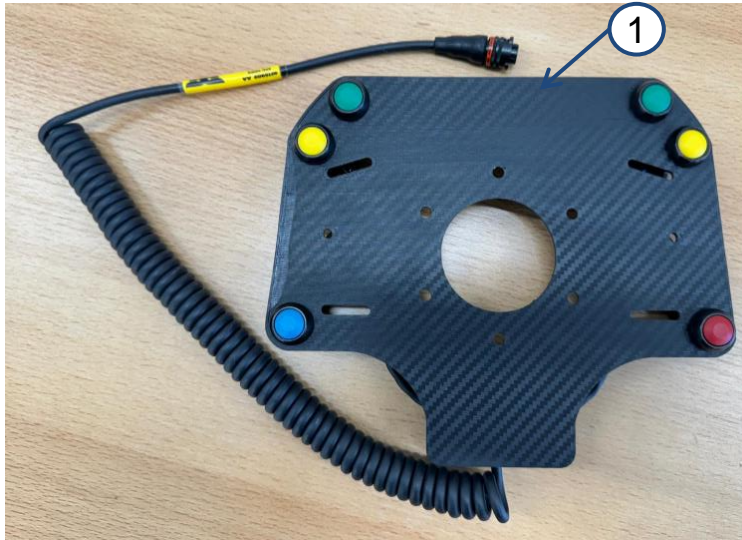

No.	Ref.	Name	Qty.
1	4018909	DRP WIRING HARNESS STEERING WHEEL WITH PLATE	1

## Section 13

### COCKPIT

# 13 COCKPIT – Overview

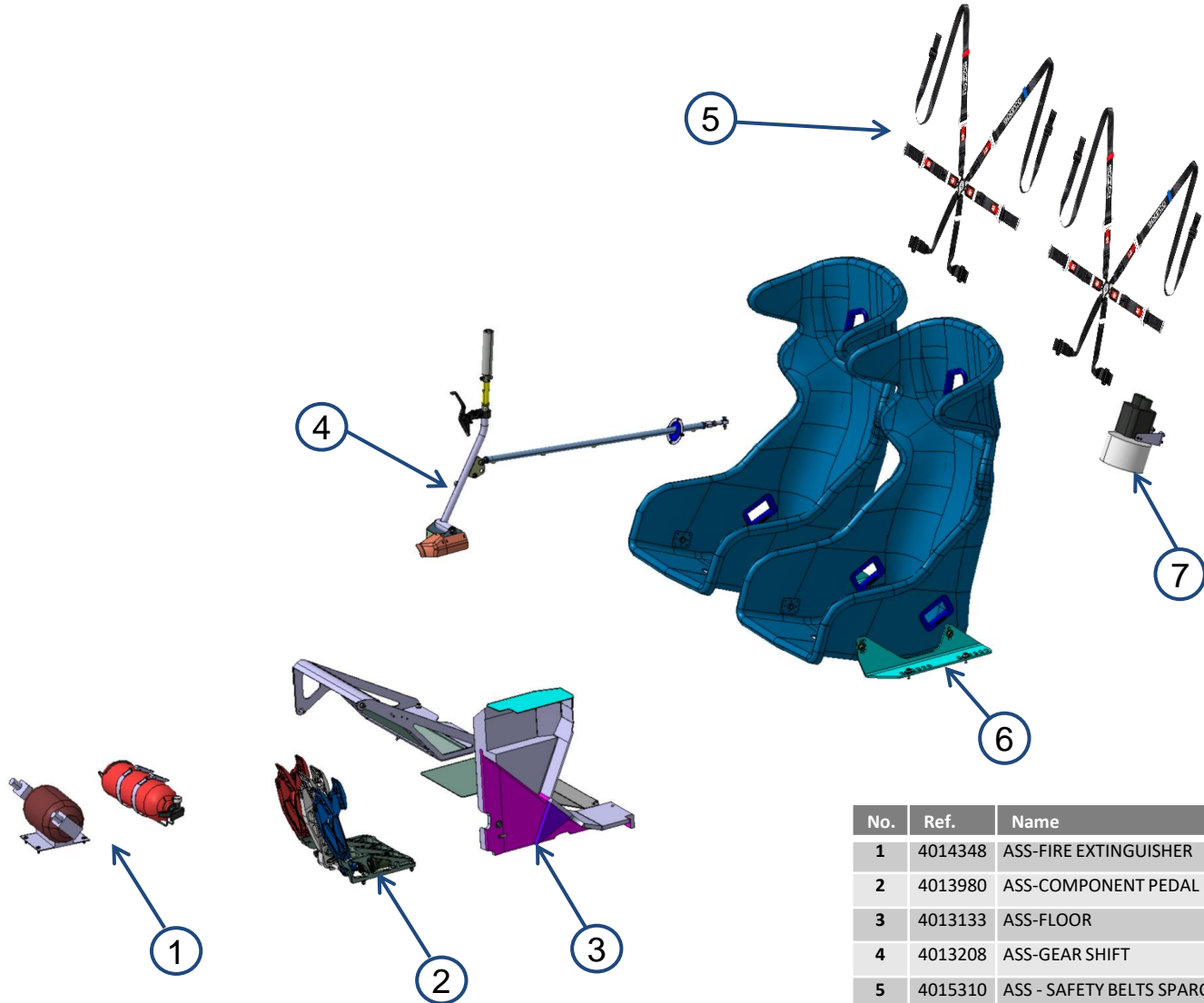
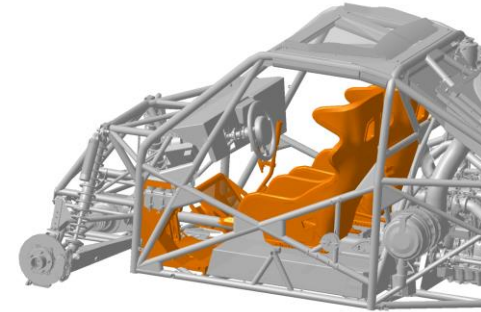

No.	Ref.	Name	Qty.
1	4014348	ASS-FIRE EXTINGUISHER	1
2	4013980	ASS-COMPONENT PEDAL BOX ASSEMBLY	1
3	4013133	ASS-FLOOR	1
4	4013208	ASS-GEAR SHIFT	1
5	4015310	ASS - SAFETY BELTS SPARCO PRIME H9 EVO CUSTOM TAURUS	2
6	4014500	ASS - SEAT	2
7	4014286	ASS - COMPONENT BLOWER	1

# 13.1 COCKPIT – Fire Extinguishers – Overview

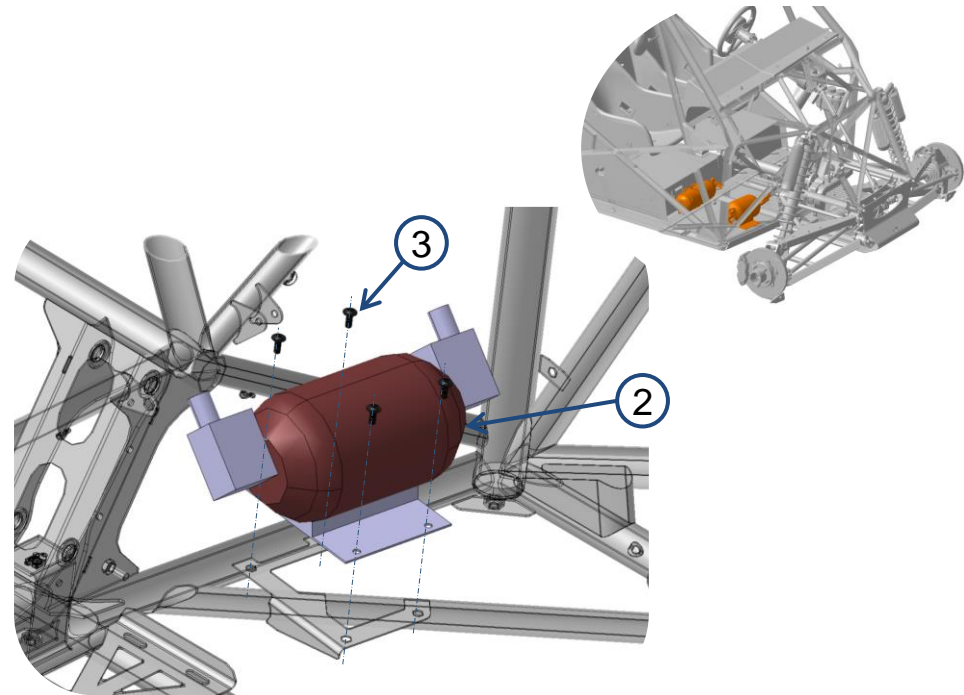
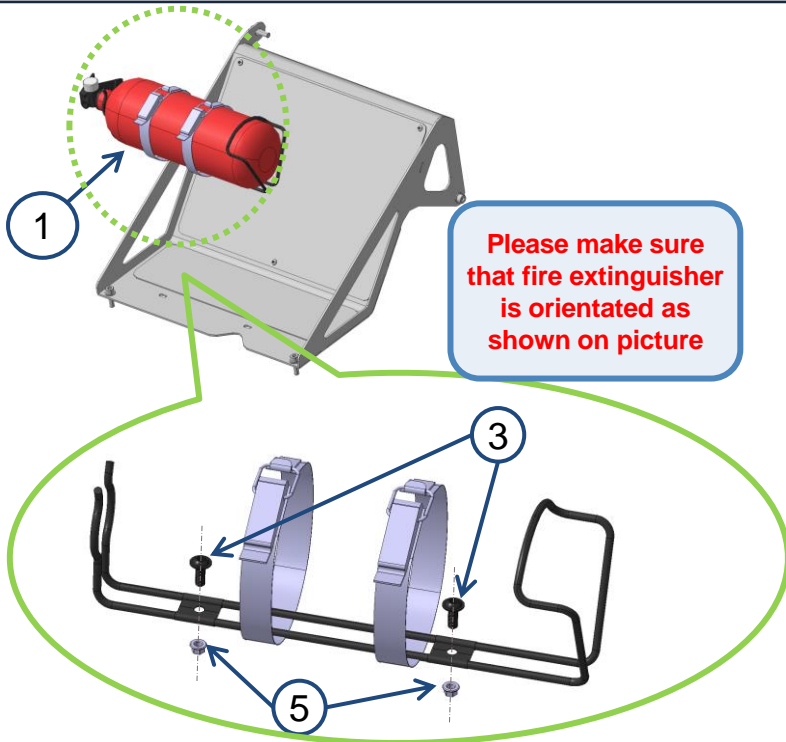

**Extinguisher stickers must be visible**

**Extinguisher function in engine bay**

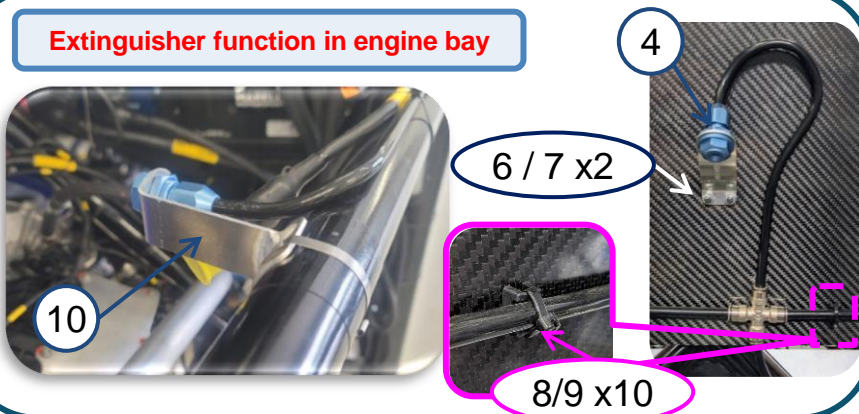

No.	Ref.	Name	Qty.
1	4013091	COP-FIRE EXTINGUISHER 2KG FIA EN3	1
2	4012722	COP-FIRE EXTINGUISHER ELEC FIA - LIFELINE KIT ZERO 275	1
3	4013534	COP-VIS TBHCEM - M6X16 P100 - CL10.9 – NOIRE	6
4	4014830	DRP-COMPONENT EXTINGUISHER NOZZLE HOLDER	1
5	4013685	SUP-LOCKNUT WITH FLANGE - M6X1.00 - SIMMONDS	2
6	4013851	COP-SCREW VIS A EMBASE TETE BASSE M5X12	2
7	4016944	SUP-LOCKNUT WITH FLANGE - M5X0.8 – SIMMONDS	2
8	4013573	COP-TO BE DEFINED EMBASE DE COLLIER A VISSER	6
9	4016996	COP-TO BE DEFINED RIVET M3X10 TETE FRAISEE	6
10	4018790	SASS-BRACKET EXTINGUISHER SIDE NOZZLE WELDED	2

# 13.2 PEDALBOX – Overview

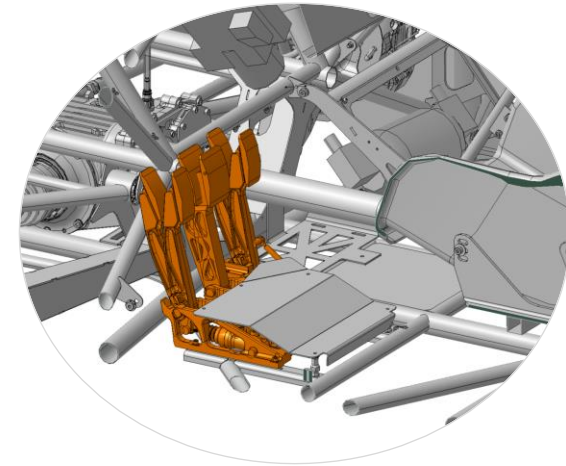
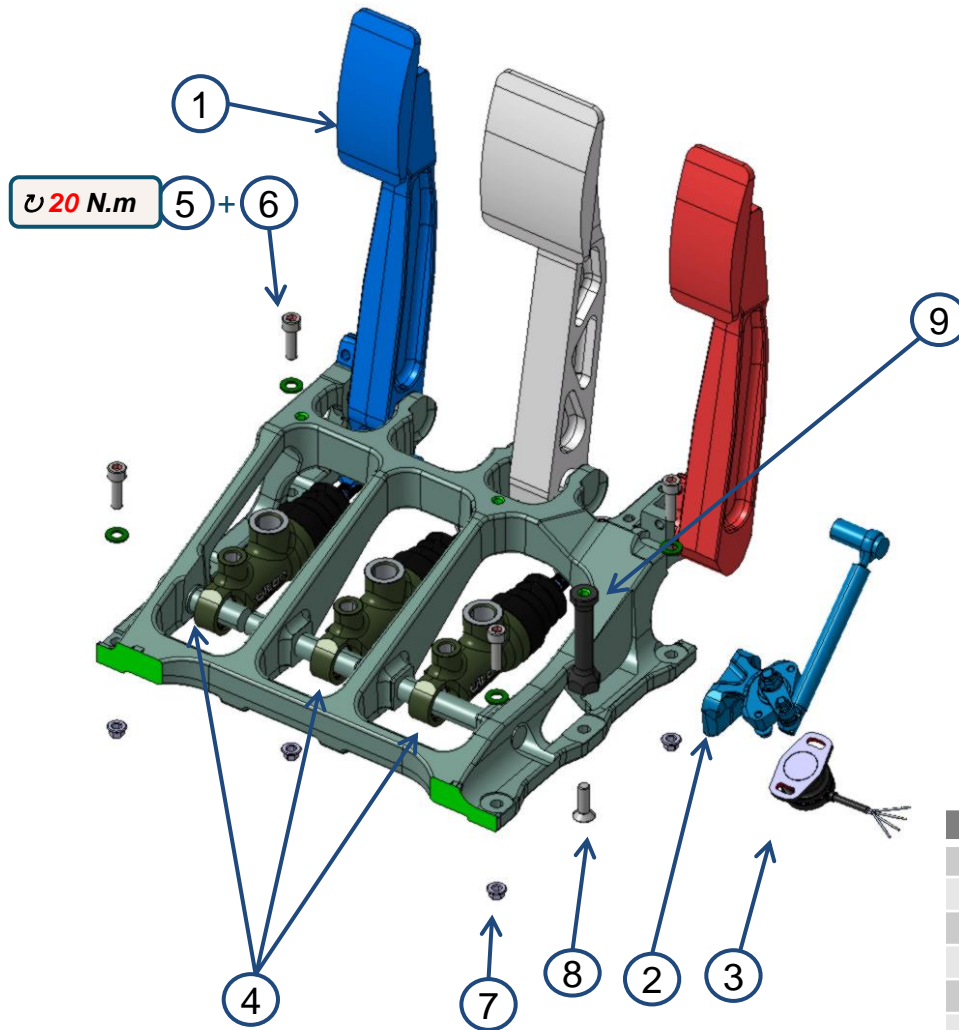

No.	Ref.	Name	Qty.
1	4015159	DRP-COMPONENT TILTON PEDAL BOX 72-856 REWORKED	1
2	4014041	COP-TILTON TROTTLER LINKAGE SYSTEM 72-794	1
3	4014725	DRP-WIRING HARNESS, ACCELERATOR PEDAL TILTON	1
4	4012927	COP-MASTER CYLINDER 78-875 Ø22.23	3
5	4000936	SUP-HEXAGONAL SOCKET CAP SCREW ISO 4762 M6X20-20 P100 CL12.9 A B	4
6	4009150	SUP-PLAIN WASHER D6XD12X1.2 TYPE Z NFE25-514 A EZ	4
7	4013685	COP-NUT M6X100 SIMMONDS	4

# 13.3.1 COCKPIT – Floor Footrest – Pilot tanks

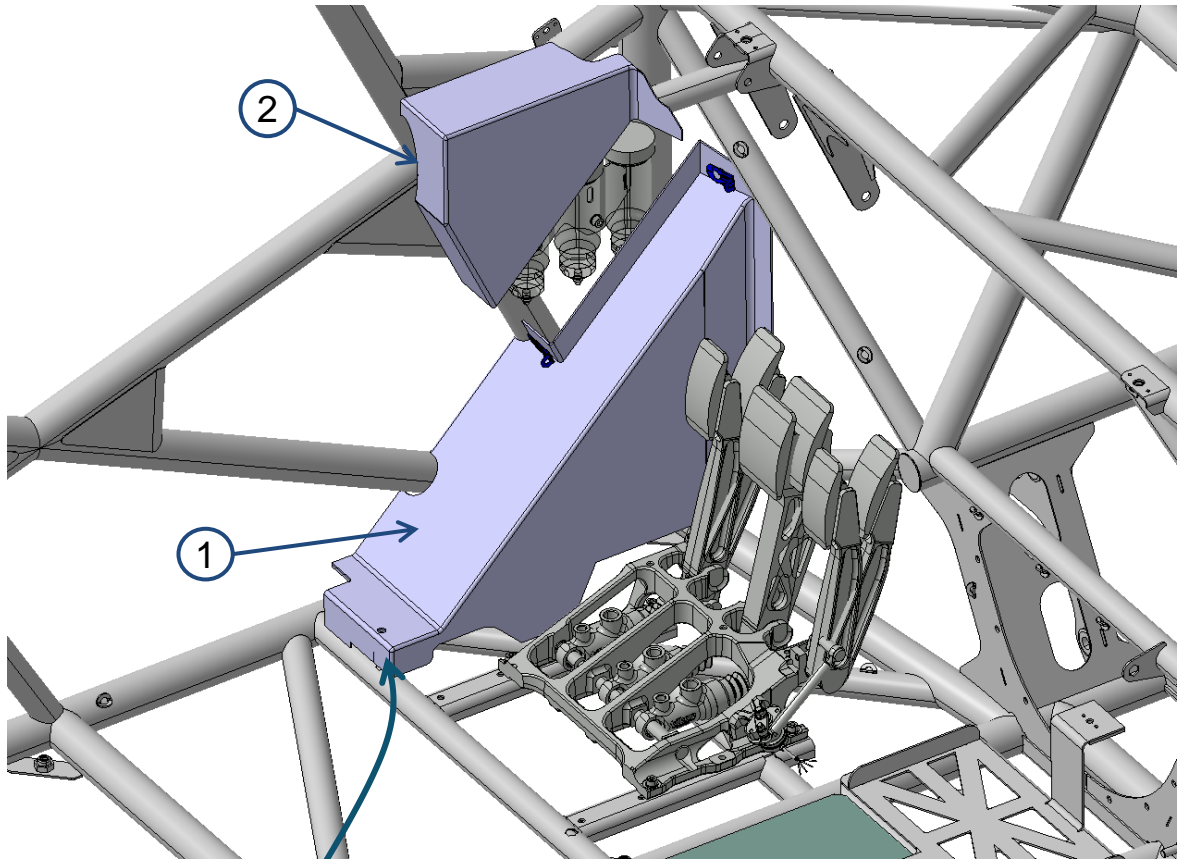

M8x55mm + Copper Grease

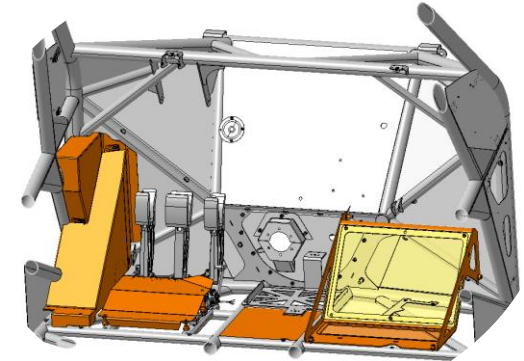

No.	Ref.	Name	Qty.
1	4016651	DRP-COMPONENT DRIVER FOOT REST BASE EVO2	1
2	4016673	DRP-COMPONENT ASM DRIVER FOOT REST CLOSING EVO2	1

## 13.3.2 COCKPIT – Floor Footrest – Pilot pedals

**Ref 1:**  
Bolts in the kit must be change  
by M6x10 (4008190)

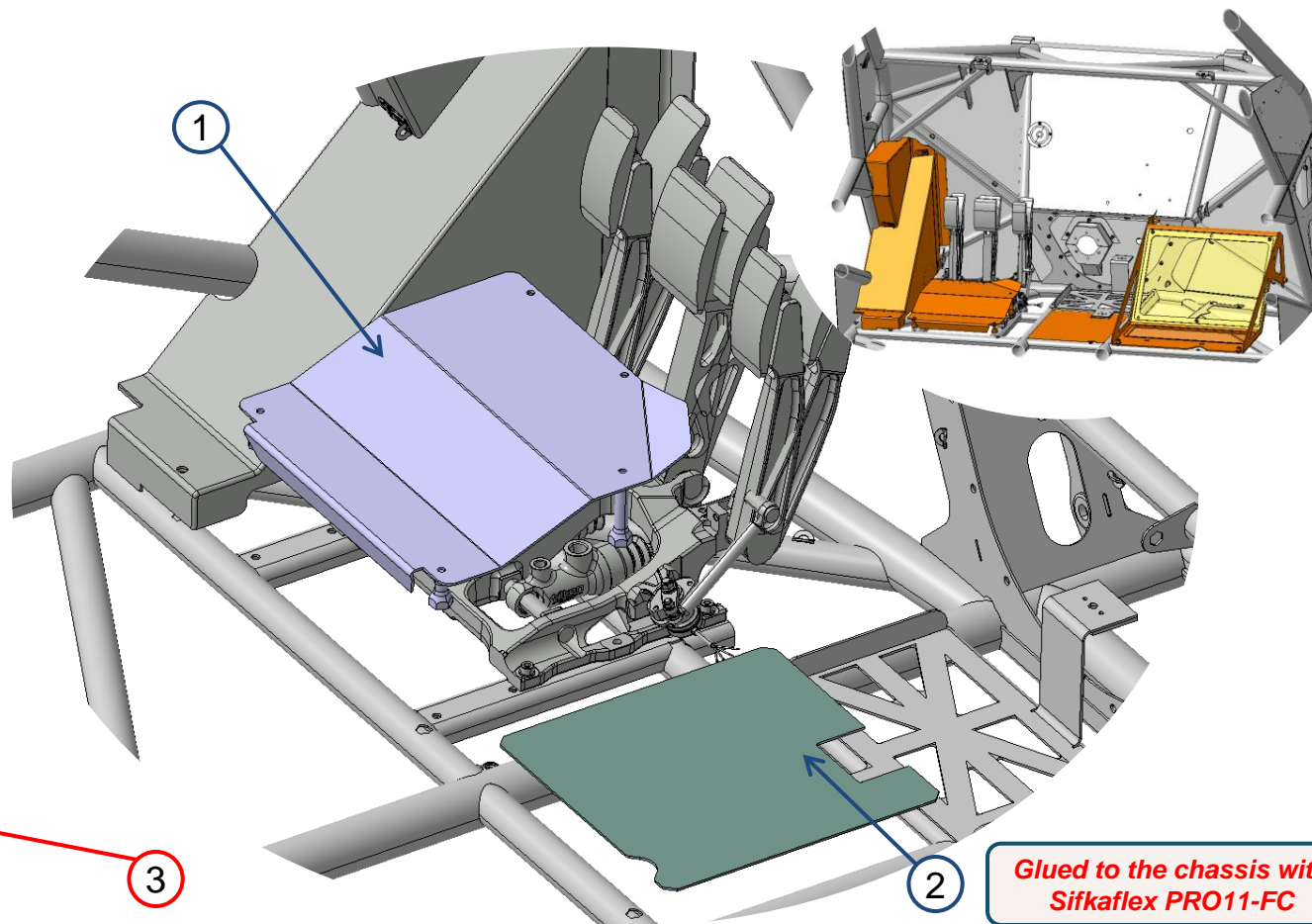

**Glued to the chassis with  
Sifkaflex PRO11-FC**

No.	Ref.	Name	Qty.
1	4018350	COP-TILTON FALSE FLOOR KIT 72-853-FF - REWORKED	1
2	4014811	DRP - PLAQUE CENTRALE COMPOSITE	1
3		COP - TAPE GRIP - GPZW15	1

# 13.3.3 COCKPIT – Floor Footrest – Copilot

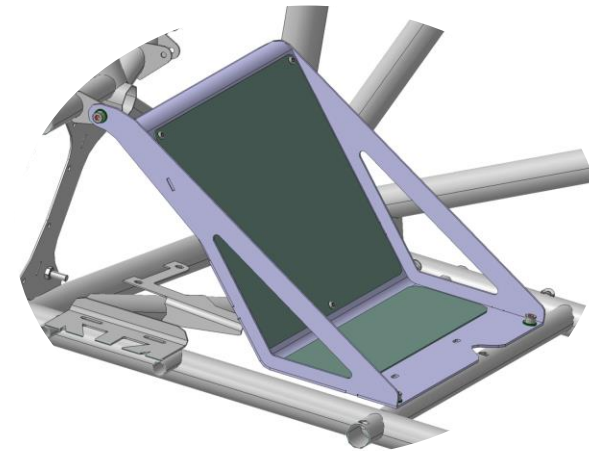
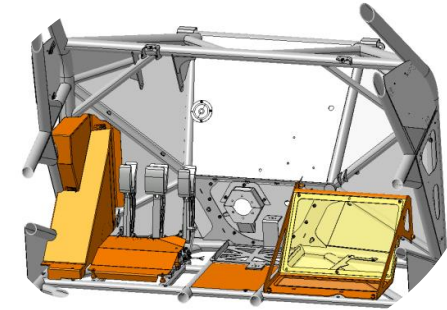
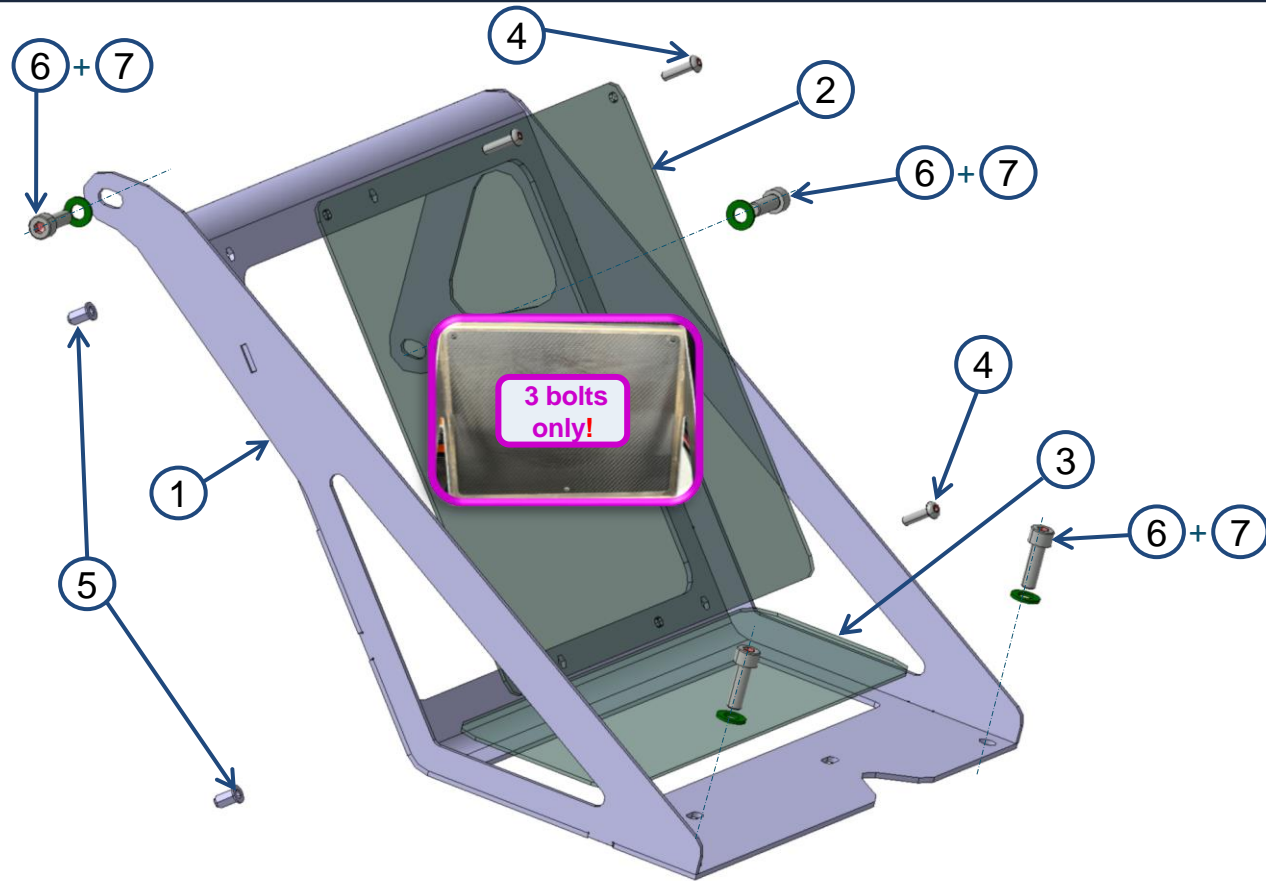

No.	Ref.	Name	Qty.
1	4016504	DRP-COMPONENT FOOTREST COPILOT - TH 3MM – WELDED	1
2	4015471	DRP-PLATE COPILOT FOOTREST	1
3	4015424	DRP-COMPONENT COPILOT FOOTREST COVER	1
4	4008179	SUP - BUTTON HEAD SCREW ISO 7380 M5X20-20 P80 CL10.9 A B	3
5	4012820	SUP – CRIMP NUT M5	3
6	4000965	SUP-HEXAGONAL SOCKET CAP SCREW ISO 4762 M8X25-25 P125 CL12.9 A B	4
7	4009151	SUP-PLAIN WASHER D8XD16X1.5 TYPE Z NFE25-514 A EZ	4



# 13.4.1.1 COCKPIT – Gear Shift

## TUBULAR VERSION

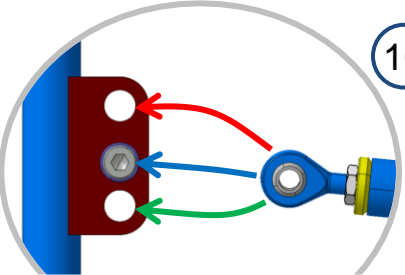

	Down Shift	Up Shift
Short Shift	33.5	45.5
Neutral	38.5	52
Long Shift	43.5	59

Simmonds locknuts must be welded to the washer plate

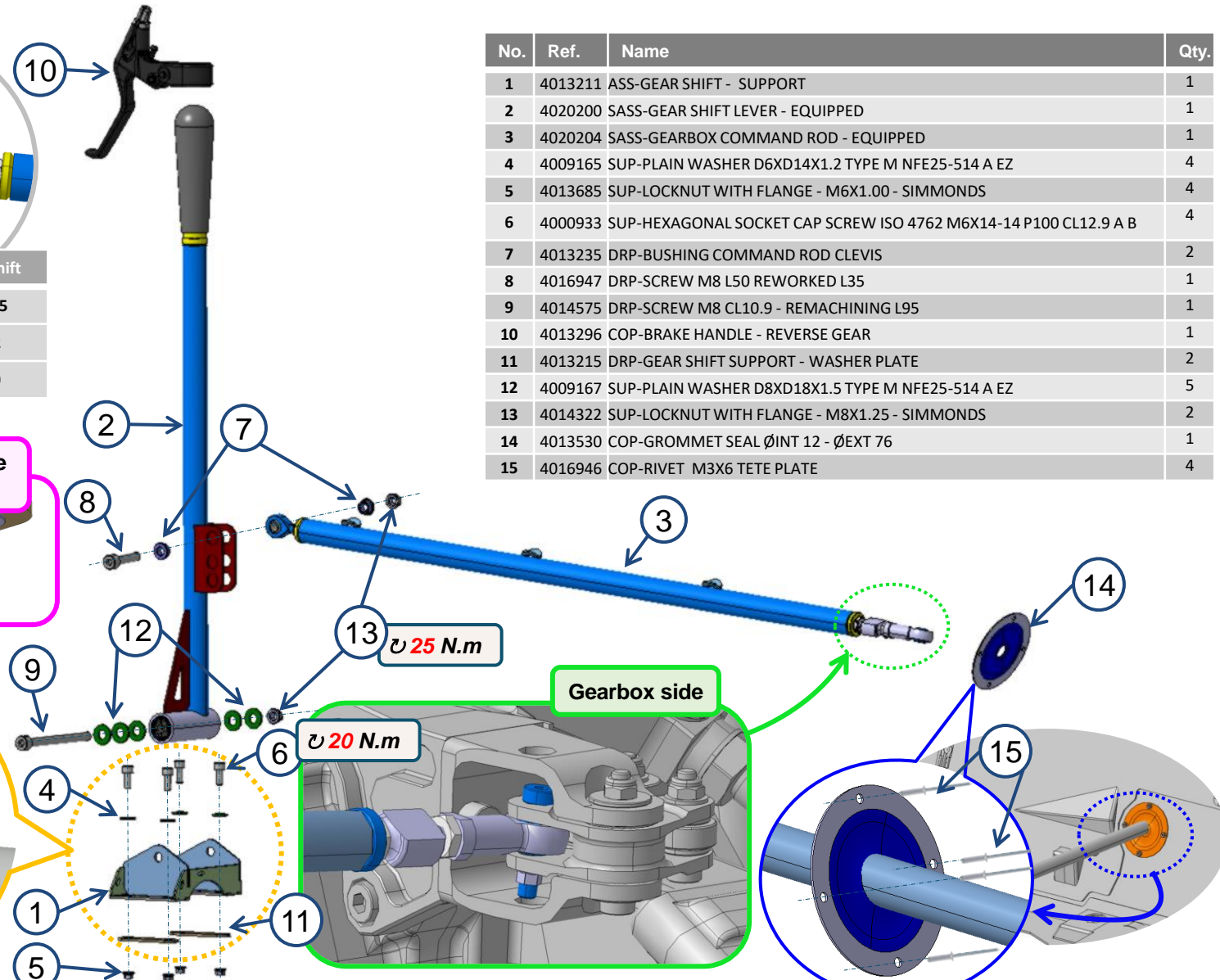
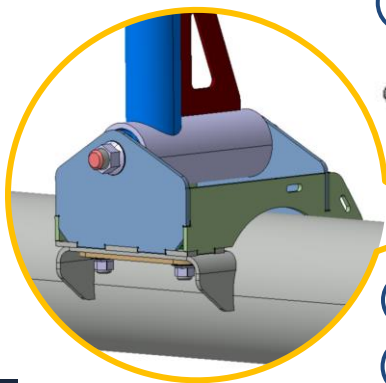

No.	Ref.	Name	Qty.
1	4013211	ASS-GEAR SHIFT - SUPPORT	1
2	4020200	SASS-GEAR SHIFT LEVER - EQUIPPED	1
3	4020204	SASS-GEARBOX COMMAND ROD - EQUIPPED	1
4	4009165	SUP-PLAIN WASHER D6XD14X1.2 TYPE M NFE25-514 A EZ	4
5	4013685	SUP-LOCKNUT WITH FLANGE - M6X1.00 - SIMMONDS	4
6	4000933	SUP-HEXAGONAL SOCKET CAP SCREW ISO 4762 M6X14-14 P100 CL12.9 A B	4
7	4013235	DRP-BUSHING COMMAND ROD CLEVIS	2
8	4016947	DRP-SCREW M8 L50 REWORKED L35	1
9	4014575	DRP-SCREW M8 CL10.9 - REMACHINING L95	1
10	4013296	COP-BRAKE HANDLE - REVERSE GEAR	1
11	4013215	DRP-GEAR SHIFT SUPPORT - WASHER PLATE	2
12	4009167	SUP-PLAIN WASHER D8XD18X1.5 TYPE M NFE25-514 A EZ	5
13	4014322	SUP-LOCKNUT WITH FLANGE - M8X1.25 - SIMMONDS	2
14	4013530	COP-GROMMET SEAL ØINT 12 - ØEXT 76	1
15	4016946	COP-RIVET M3X6 TETE PLATE	4

# 13.4.1.2 COCKPIT – Gear Shift – Lever

**TUBULAR VERSION**

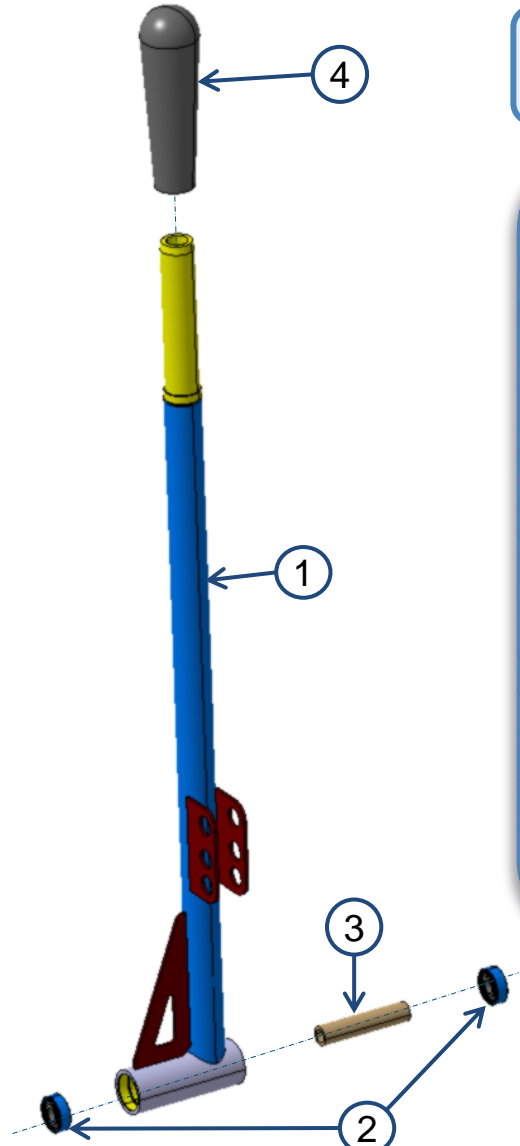

**Cable orientation mandatory to avoid the sand to lock it**

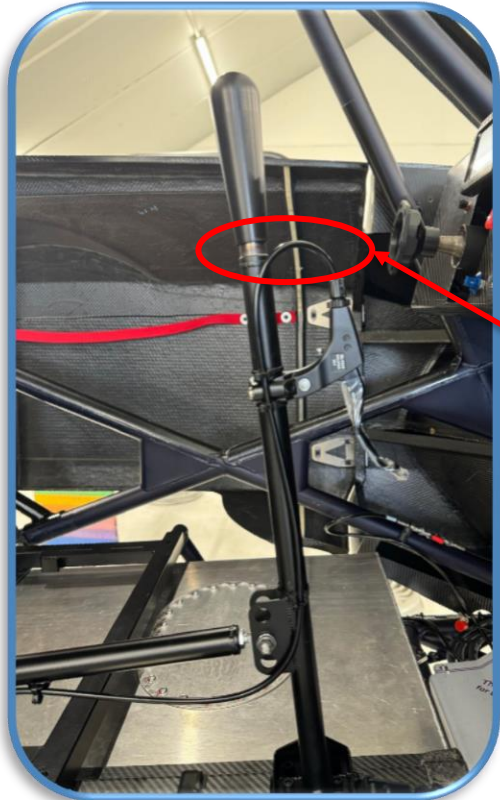

**The top of the loop must be lower than the gear stick**

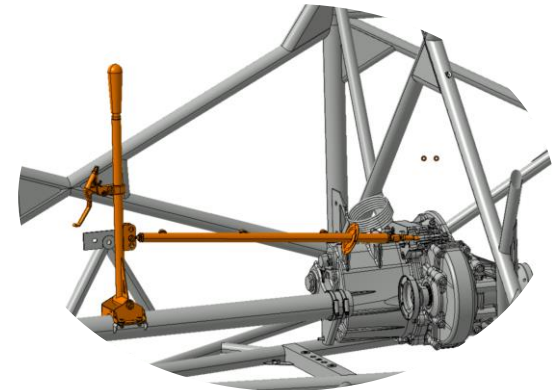

No.	Ref.	Name	Qty.
1	4020198	SASS-GEAR SHIFT LEVER - WELDED	1
2	4012999	COP-BEARING BALL - OD22 ID8 W8 - SKF 608-2RSH	2
3	4014729	DRP-SHIM BALLS BEARING HARD STOP	1
4	4020199	SUP-GEAR SHIFT KNOB - 6VT713140J	1

# 13.4.1.3 COCKPIT – Gear Shift – Command Rod

## TUBULAR VERSION

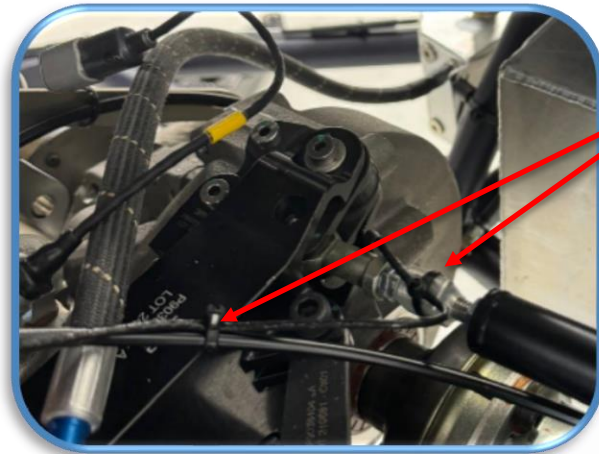

- Shifter cable installation:**
- Loop with 1 tyrap on the sensor body
  - Tyrap on the gearbox cable

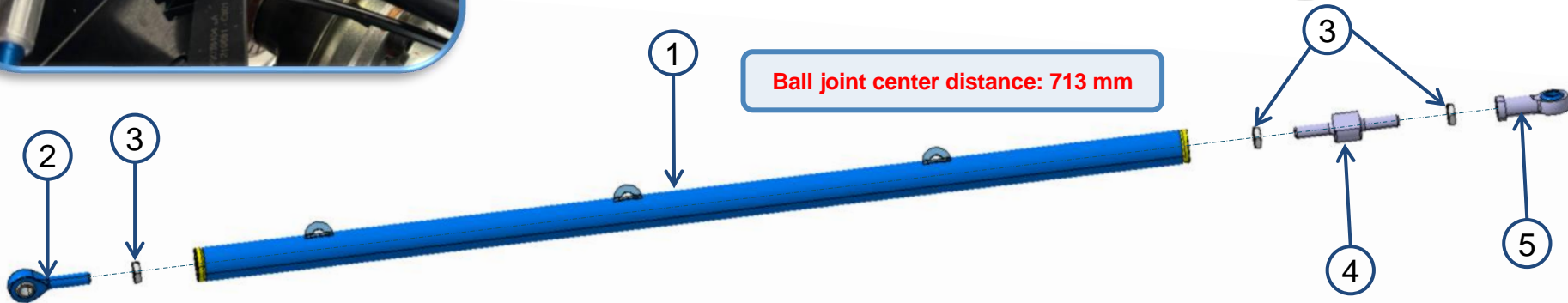
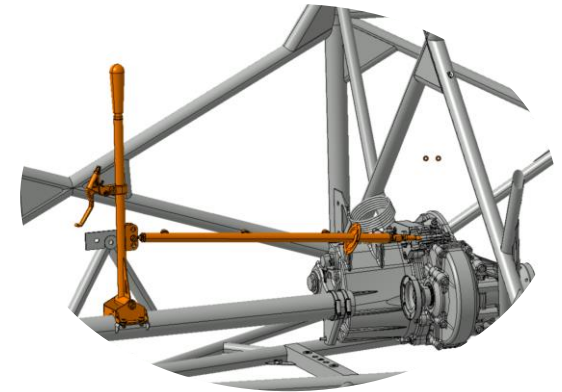

No.	Ref.	Name	Qty.
1	4020203	SASS-GEARBOX COMMAND ROD – WELDED	1
2	4012397	COP-BALL JOINT UNIBAL SMG 8 – RIGHT	1
3	4008672	SUP-JAM NUT HM M8X4 P125 CL05 ISO4035 A B	3
4	4015191	DRP-WIRED STRAIN GAUGE	1
5	4013226	COP-BALL JOINT UNIBAL SFG8	1

# 13.4.2.1 COCKPIT – Gear Shift – Support

**Mandatory  
for composite Fuel**



**Gearbox side**

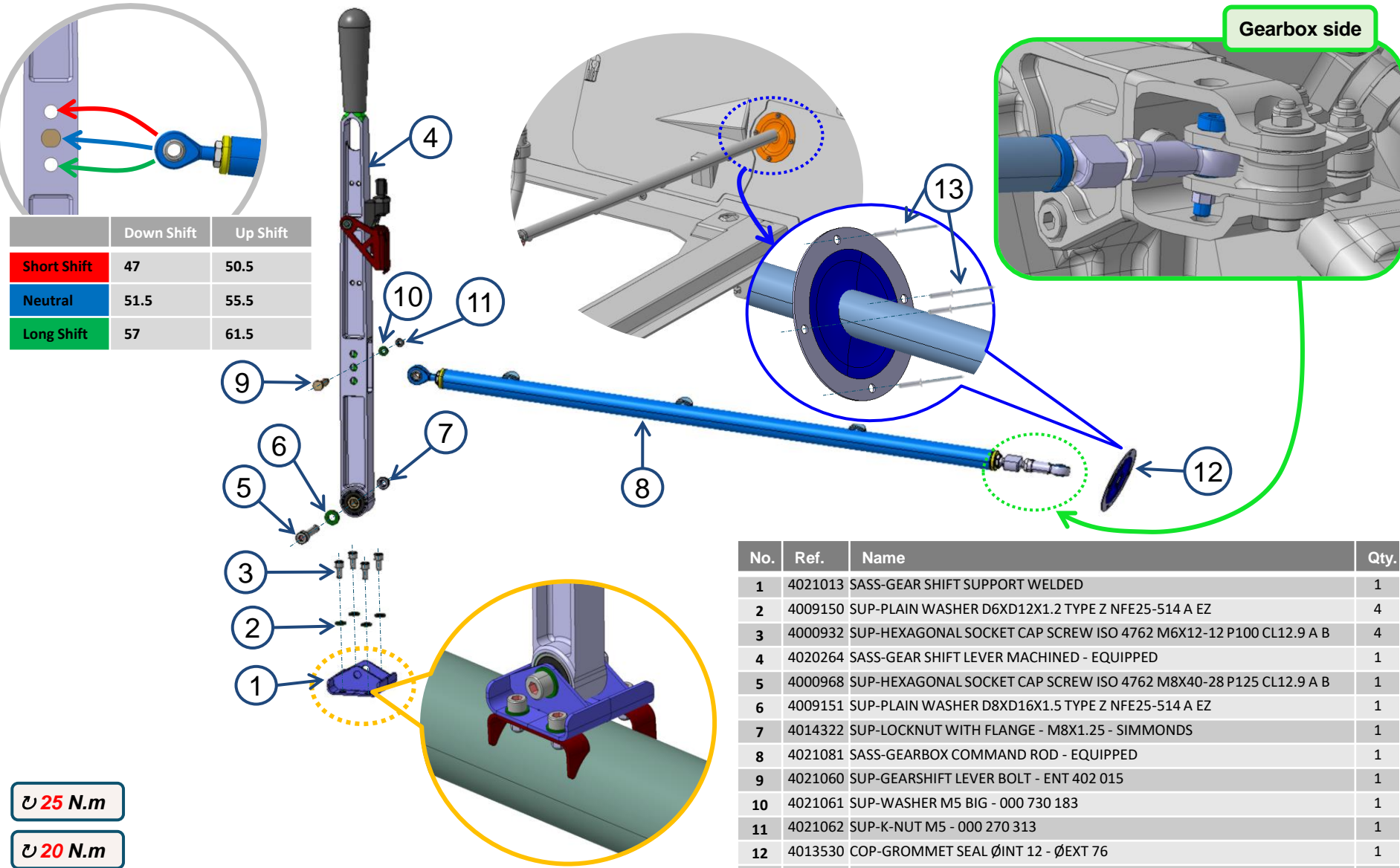

	Down Shift	Up Shift
Short Shift	47	50.5
Neutral	51.5	55.5
Long Shift	57	61.5

⤵ **25 N.m**

⤵ **20 N.m**

No.	Ref.	Name	Qty.
1	4021013	SASS-GEAR SHIFT SUPPORT WELDED	1
2	4009150	SUP-PLAIN WASHER D6XD12X1.2 TYPE Z NFE25-514 A EZ	4
3	4000932	SUP-HEXAGONAL SOCKET CAP SCREW ISO 4762 M6X12-12 P100 CL12.9 A B	4
4	4020264	SASS-GEAR SHIFT LEVER MACHINED - EQUIPPED	1
5	4000968	SUP-HEXAGONAL SOCKET CAP SCREW ISO 4762 M8X40-28 P125 CL12.9 A B	1
6	4009151	SUP-PLAIN WASHER D8XD16X1.5 TYPE Z NFE25-514 A EZ	1
7	4014322	SUP-LOCKNUT WITH FLANGE - M8X1.25 - SIMMONDS	1
8	4021081	SASS-GEARBOX COMMAND ROD - EQUIPPED	1
9	4021060	SUP-GEARSHIFT LEVER BOLT - ENT 402 015	1
10	4021061	SUP-WASHER M5 BIG - 000 730 183	1
11	4021062	SUP-K-NUT M5 - 000 270 313	1
12	4013530	COP-GROMMET SEAL ØINT 12 - ØEXT 76	1
13	4016946	COP-RIVET M3X6 TETE PLATE	4

## 13.4.2.2 COCKPIT – Gear Shift – Hardware

**Mandatory  
for composite Fuel**

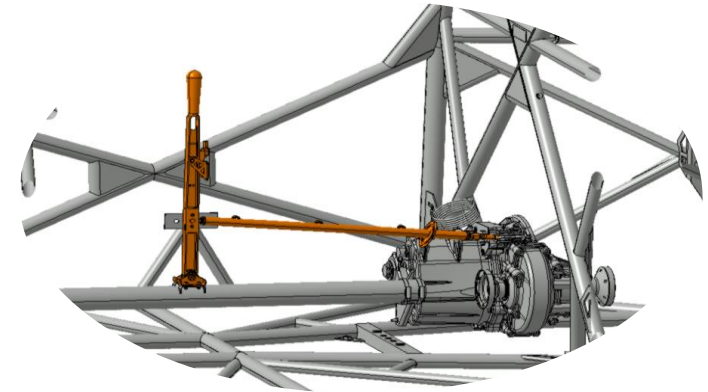
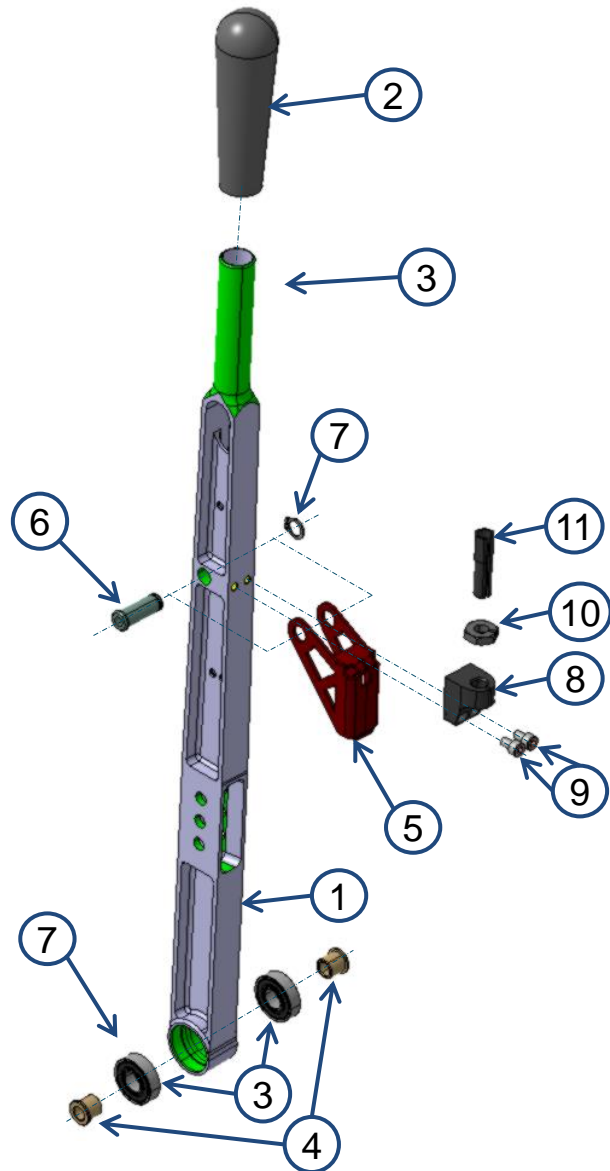

No.	Ref.	Name	Qty.
1	4020262	DRP-GEAR SHIFT LEVER MACHINED	1
2	4020199	SUP-GEAR SHIFT KNOB - 6VT713140J	1
3	4020261	SUP-LEVER BALL BEARING - 000 607 007	2
4	4020266	DRP-SPACER GEAR SHIFT BEARING	2
5	4021019	SUP-BOWDEN LEVER - 6VT 711 712F	1
6	4021058	SUP-BOWDEN LEVER PIN - 6VT 711 158 A	1
7	4021059	SUP-CIRCLIP 10 - 000 419 064	1
8	4021020	SUP-BOWDEN HOLDER - 6VT 721 116	1
9	4021057	SUP-BOLT M5X10 SOCKET HEAD - C60 F05 010	2
10	4021056	SUP-NUT M10X1 - ENT 402 001 DJ	1
11	4021021	SUP-BOWDEN BOLT - 6VT 713 092	1

# 13.4.2.3 COCKPIT – Gear Shift – Command Rod

**Mandatory for composite Fuel**

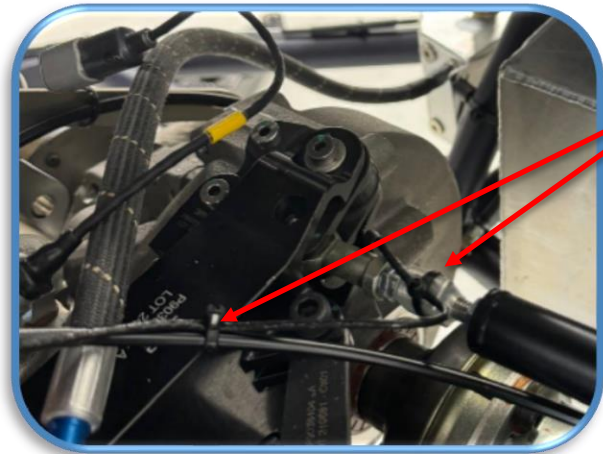

**Shifter cable installation:**

- Loop with 1 tyrap on the sensor body
- Tyrap on the gearbox cable

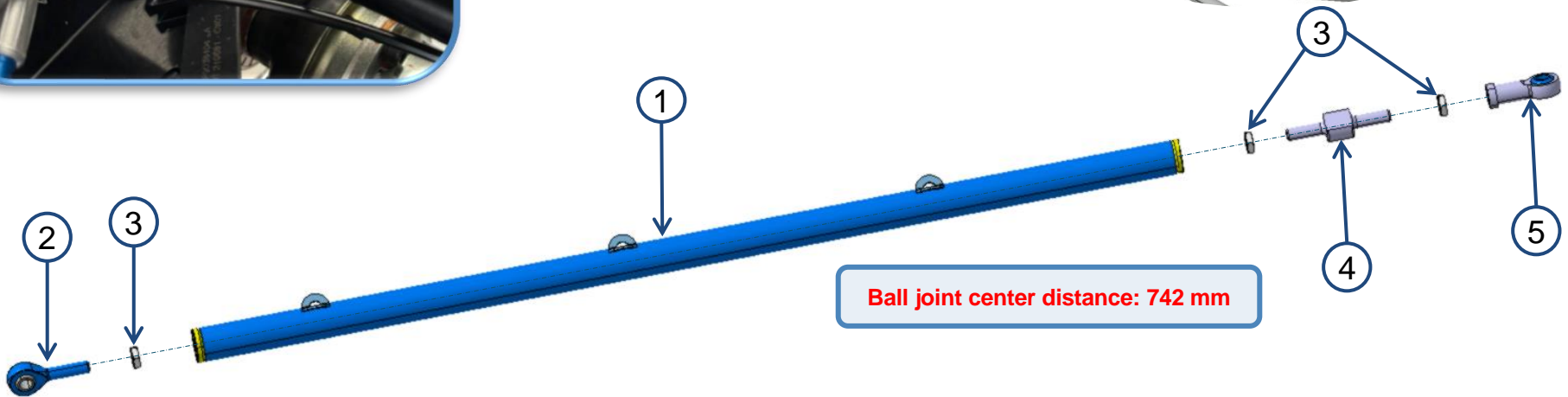
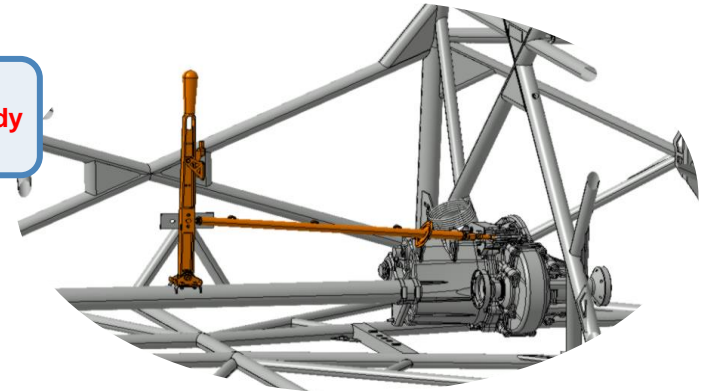

**Ball joint center distance: 742 mm**

No.	Ref.	Name	Qty.
1	4021080	SASS-GEARBOX COMMAND ROD – WELDED	1
2	4012397	COP-BALL JOINT UNIBAL SMG 8 – RIGHT	1
3	4008672	SUP-JAM NUT HM M8X4 P125 CL05 ISO4035 A B	3
4	4015191	DRP-WIRED STRAIN GAUGE	1
5	4013226	COP-BALL JOINT UNIBAL SFG8	1

# 13.5.1 COCKPIT – Safety Belts – Overview

**Update not needed with  
4019656 safety belt**



Remove the metal links included with the Sparco seat belt and replace them with [4017046] (No. 3)

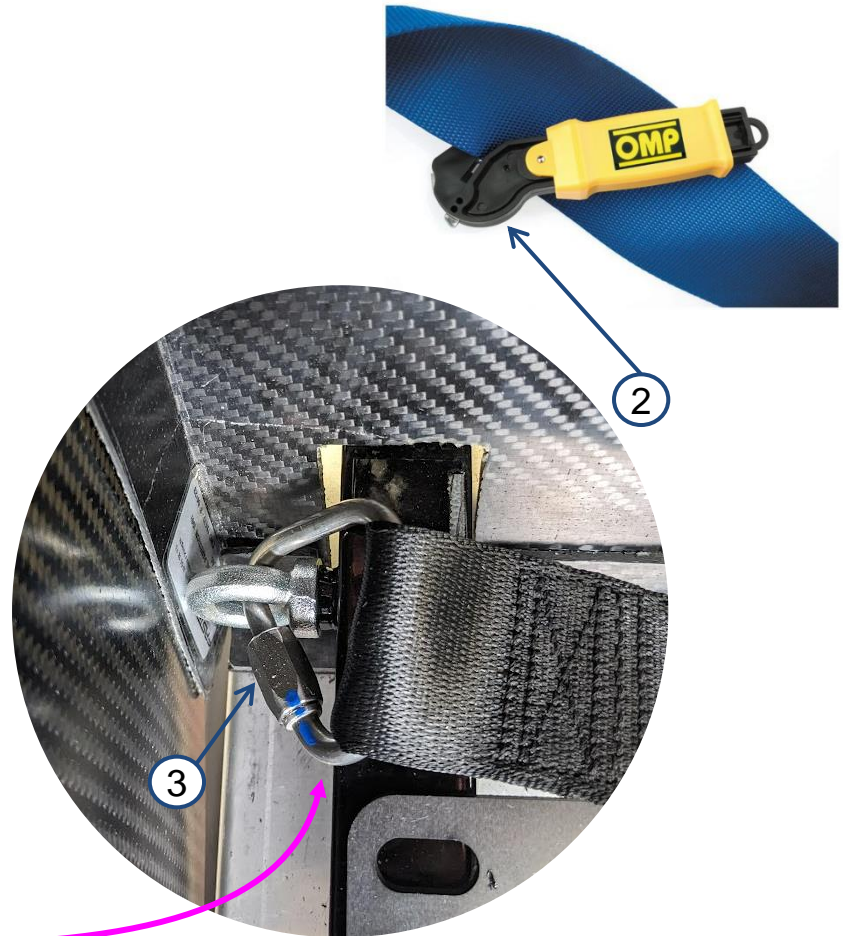

No.	Ref.	Name	Qty.
1	4013318	COP-HARNESS SPARCO 6P PRIME H-9 EVO	2
2	4013319	COP-HARNESS CUTTER	2
3	4017046	COP-LINK DELTA INOX 6MM	4

## 13.5.2 COCKPIT – Safety Belts – Installation details

Only for  
4013318  
safety belt

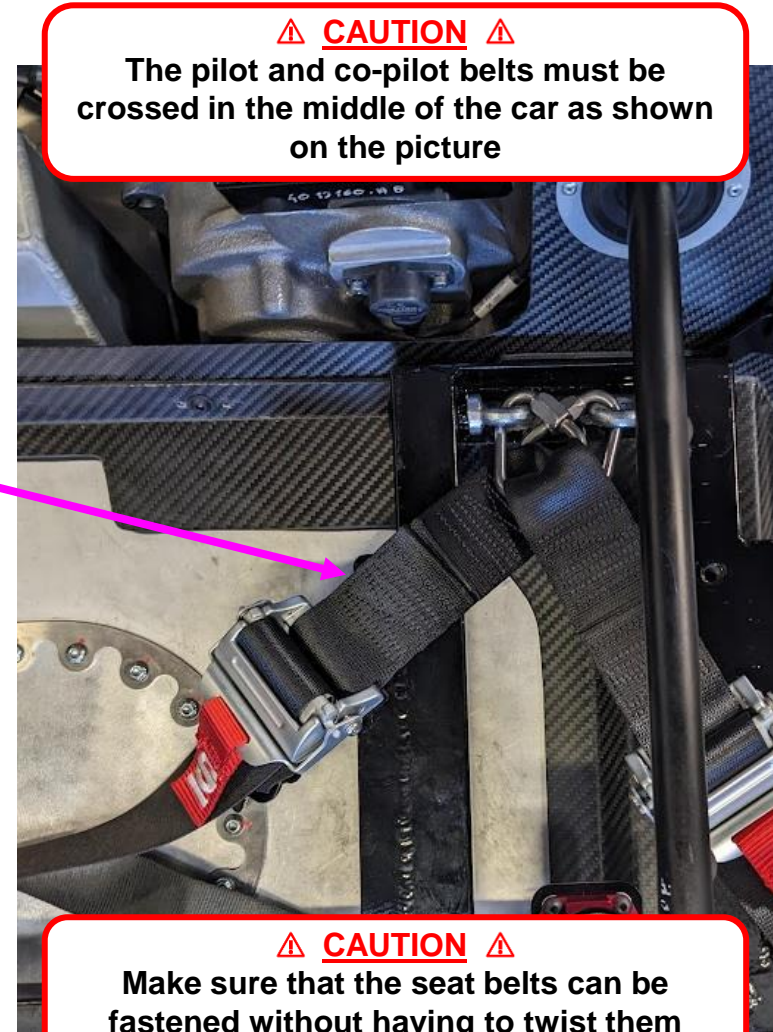

**⚠ CAUTION ⚠**  
The pilot and co-pilot belts must be  
crossed in the middle of the car as shown  
on the picture

**⚠ CAUTION ⚠**  
Make sure that the seat belts can be  
fastened without having to twist them



# 13.5.3 COCKPIT – Safety Belts – Overview



No.	Ref.	Name	Qty.
1	4019656	COP-HARNESS SPARCO 6P PRIME H-9 EVO - CUSTOM TAURUS	2
2	4013319	COP-HARNESS CUTTER	2

# 13.6 COCKPIT – Seats

## Aluminum fuel tank



SPARCO CIRCUIT QRT VERSION

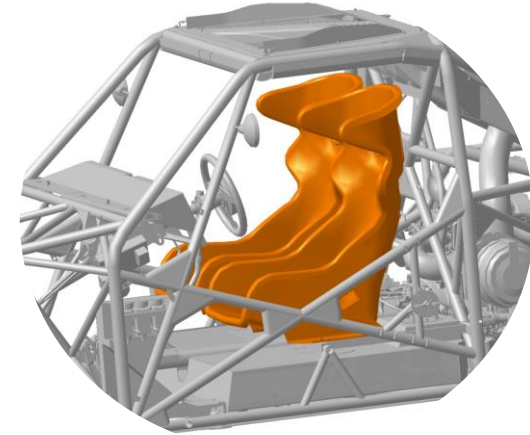
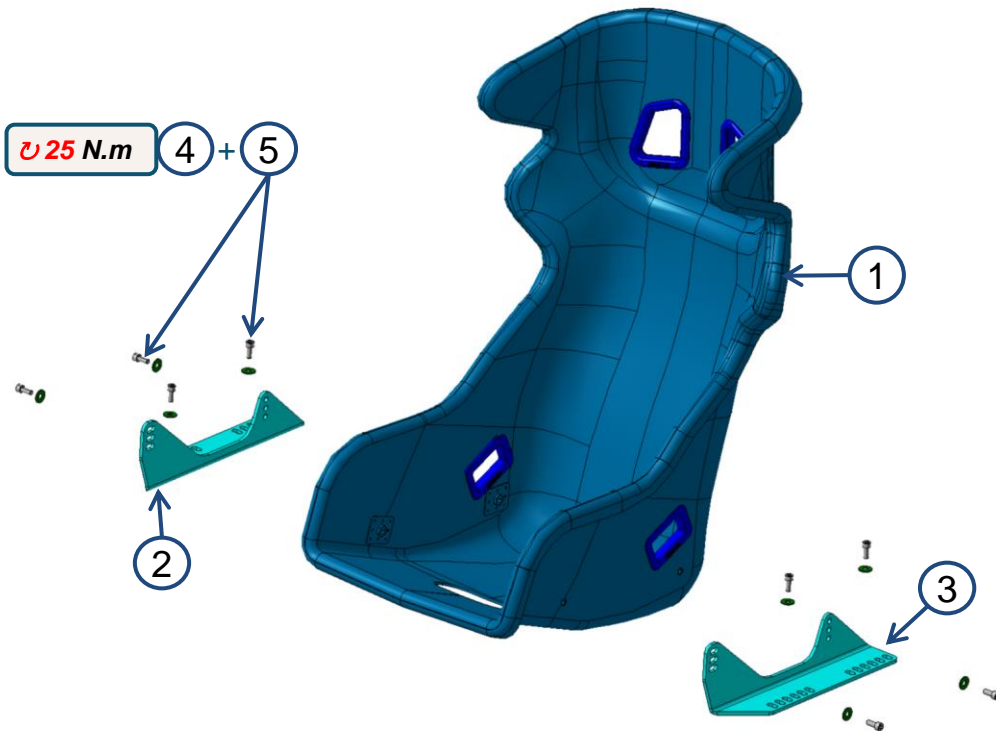

Other SPARCO seat references & brackets available by customer request.

No.	Ref.	Name	Qty.
1	4014501	COP-SEAT SPARCO CIRCUIT M/L QRT	2
2	4018820	DRP-COMPONENT CIRCUIT SEAT BRACKET 6MM ALU RIGHT	2
3	4018821	DRP-COMPONENT CIRCUIT SEAT BRACKET 6MM ALU LEFT	2
4	4009191	SUP-PLAIN WASHER D8XD22X1.5 TYPE L NFE25-514 A EZ	16
5	4000963	SUP-HEXAGONAL SOCKET CAP SCREW ISO 4762 M8X20-20 P125 CL12.9 A B	16

# 13.6.1 COCKPIT – Seats

**Composite fuel tank**



SPARCO CIRCUIT QRT VERSION

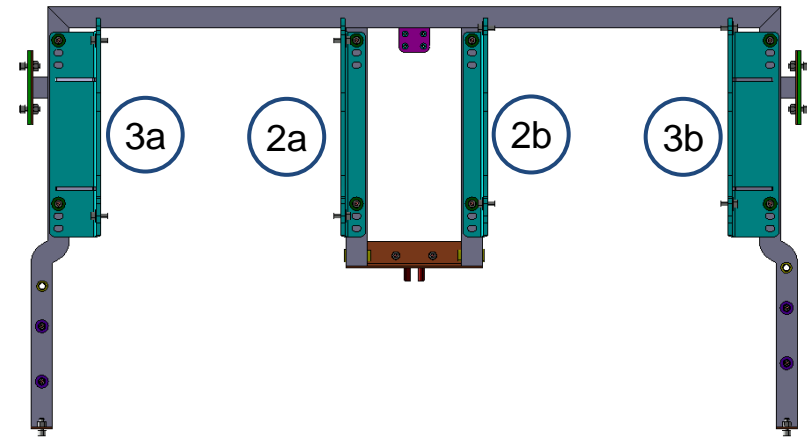
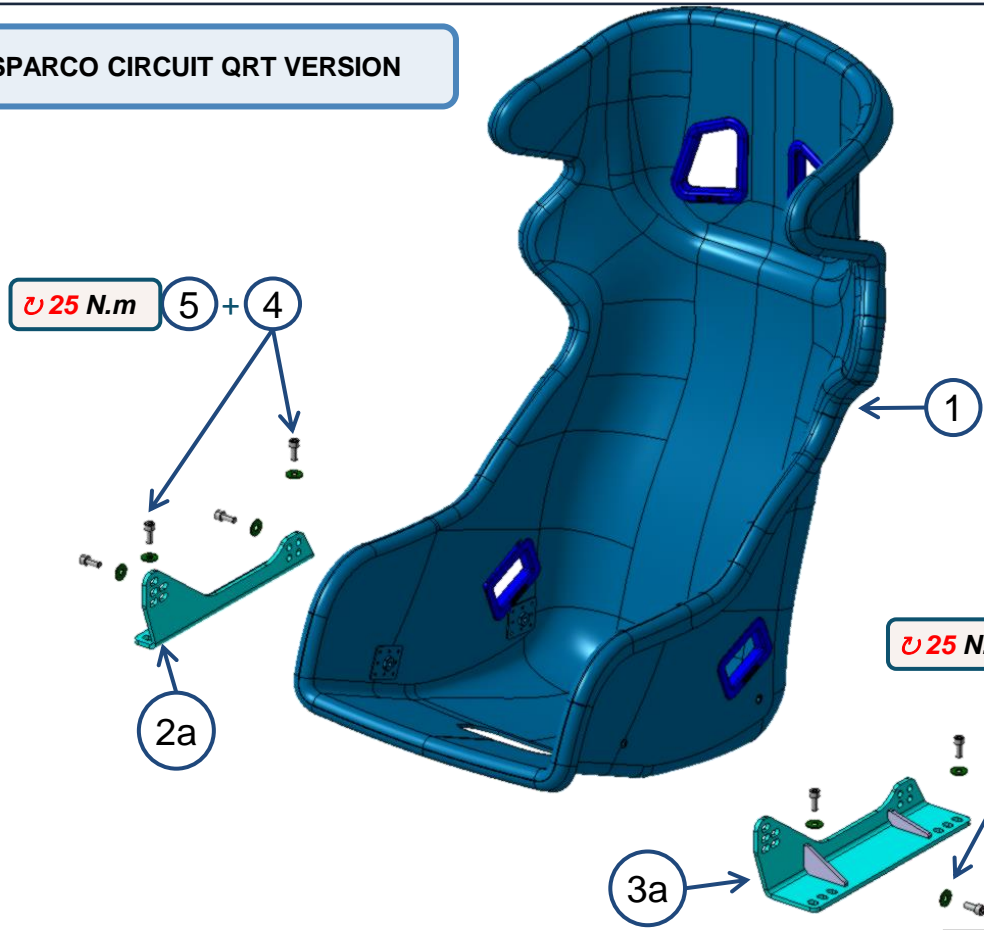

Other SPARCO seat references & brackets available by customer request.

No.	Ref.	Name	Qty.
1	4014501	COP-SEAT SPARCO CIRCUIT M/L QRT	2
2a	4011439	DRP-COMPONENT SEAT BRACKET DRIVER RIGHT	1
3a	4021437	SASS-SEAT BRACKET DRIVER LEFT - WELDED	1
2b	4021440	DRP-COMPONENT SEAT BRACKET CO-DRIVER LEFT	
3b	4021436	SASS-SEAT BRACKET CO-DRIVER RIGHT - WELDED	
4	4009191	SUP-PLAIN WASHER D8XD22X1.5 TYPE L NFE25-514 A EZ	16
5	4000966	SUP-HEXAGONAL SOCKET CAP SCREW ISO 4762 M8X30-20 P125 CL12.9 A B	8
6	4000963	SUP-HEXAGONAL SOCKET CAP SCREW ISO 4762 M8X20-20 P125 CL12.9 A B	8

# 13.7 COCKPIT – Blower

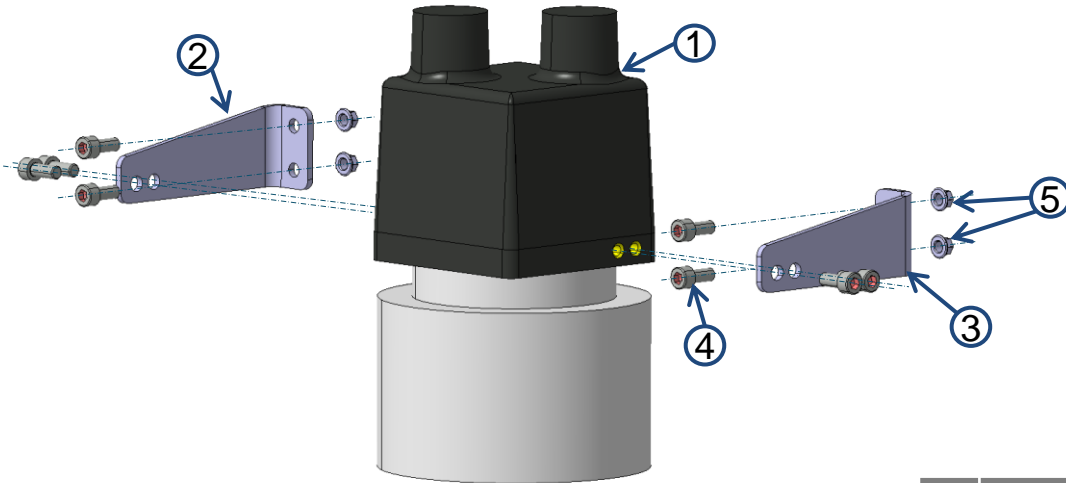
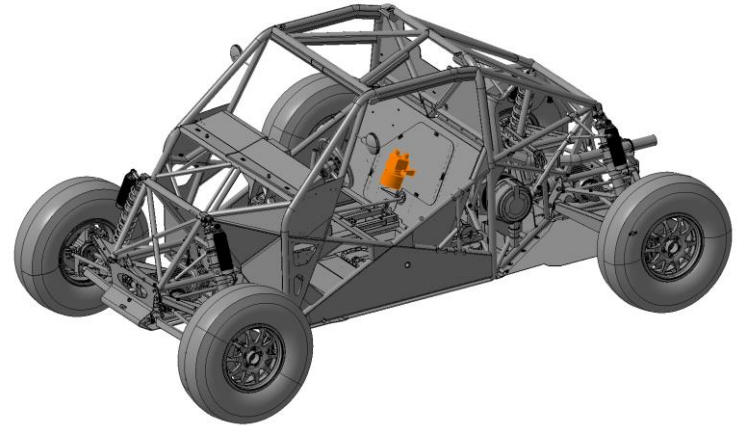

No.	Ref.	Name	Qty.
1	4016605	SASS-HARNES BLOWER WIRING	1
2	4014287	DRP-SHEET BLOWER SUPPORT – RIGHT	1
3	4014288	DRP-BLOWER SUPPORT – LEFT	1
4	4000585	SUP-HEXAGONAL SOCKET CAP SCREW ISO 4762 M6X14-14 P100 CL10.9 A B	8
5	4013685	SUP-LOCKNUT WITH FLANGE - M6X1.00 - SIMMONDS	4
ELEC	4016604	SASS-HARNES EXTENSION BLOWER/COCKPIT	1

# 13.8 INTERIOR TRIM – Overview

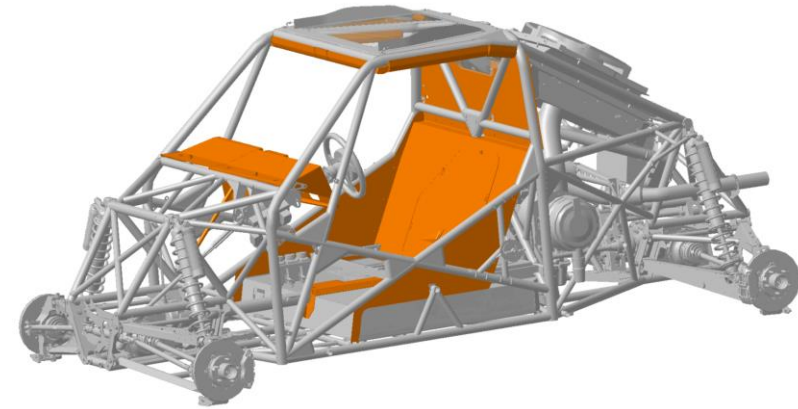
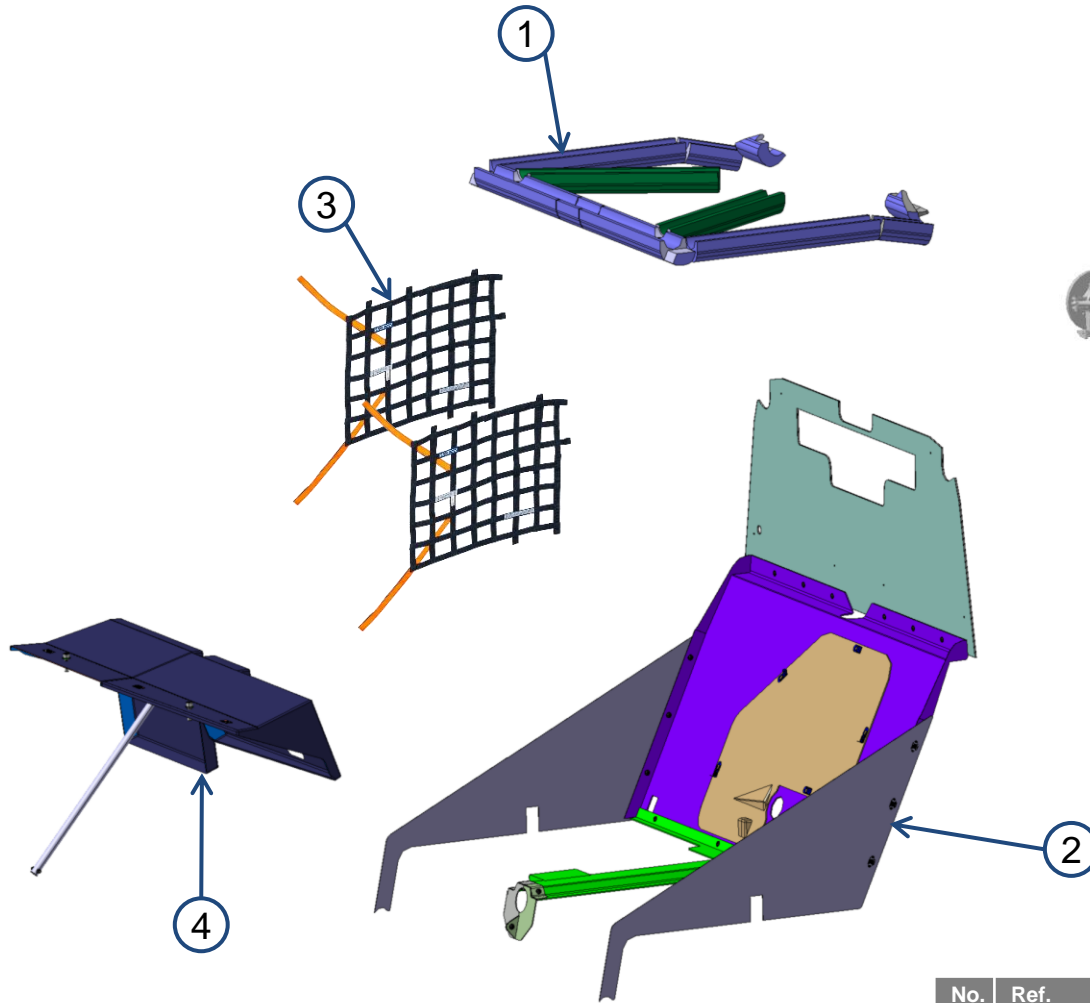

No.	Ref.	Name	Qty.
1	4014426	ASS-COMPONENT DASHBOARD COMPOSITE	1
2	4014473	ASS-COMPONENT INTERIOR TRIM COMPOSITE	1
3	4014572	ASS-ROLL BAR PROTECTIVE FOAM	1
4	4015312	ASS-WINDOW NET	1

# 13.8.1 INTERIOR TRIM – Partition Under Seats

## Aluminum fuel tank

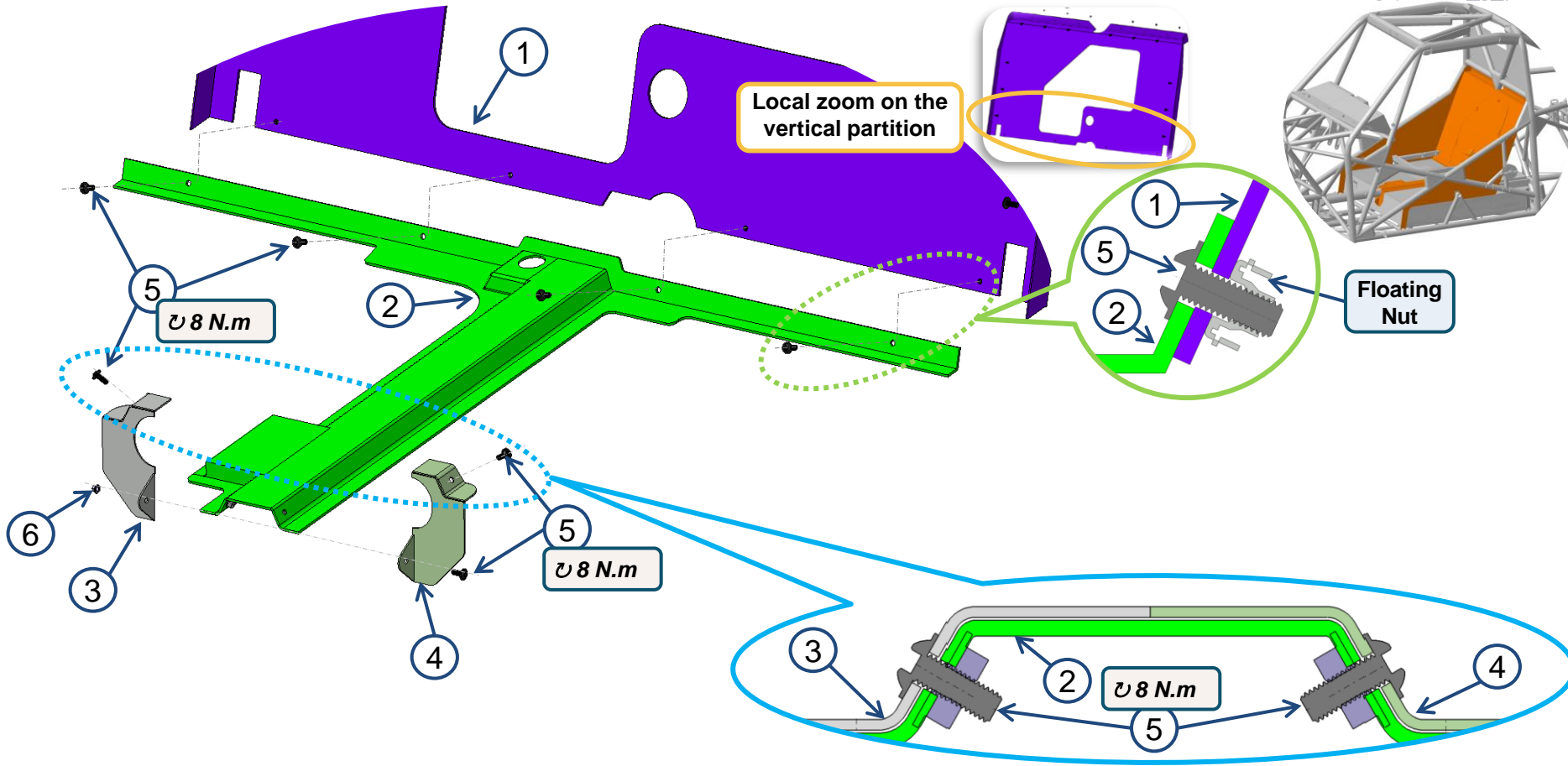
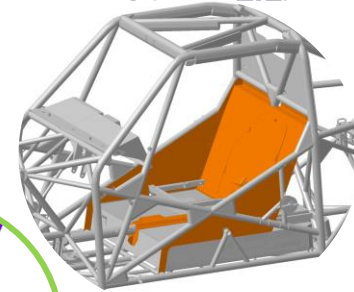

**Assembly tips .???**

No.	Ref.	Name	Qty.
1	4015035	SASS-COMPONENT CARBON VERTICAL PARTITION EQT	1
2	4014375	DRP-COMPONENT CARBON PROTECTION TANK COCKPIT CENTRAL	1
3	4014389	DRP-COMPONENT FRONT CLOSED TANK LEFT	1
4	4014390	DRP-COMPONENT FRONT CLOSED TANK RIGHT	1
5	4013534	COP-SCREW BUTTON HEAD WITH FLANGE - M6X16 P100 - CL10.9 – BLACK	7
6	4013685	SUP-LOCKNUT WITH FLANGE - M6X1.00 - SIMMONDS	1

# 13.8.2.1 INTERIOR TRIM – Partition Under Seats **Composite fuel tank**

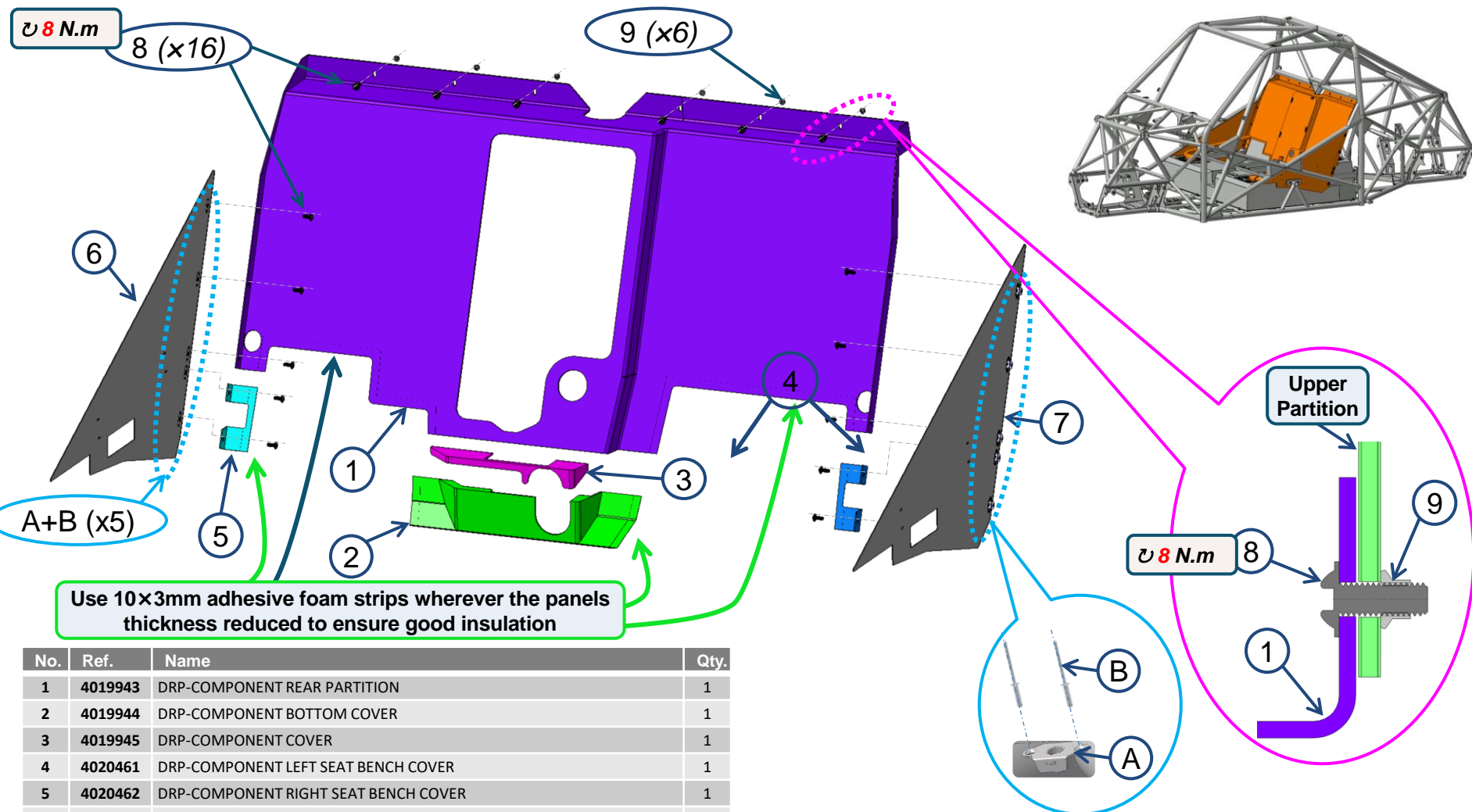

Use 10x3mm adhesive foam strips wherever the panels thickness reduced to ensure good insulation

No.	Ref.	Name	Qty.
1	4019943	DRP-COMPONENT REAR PARTITION	1
2	4019944	DRP-COMPONENT BOTTOM COVER	1
3	4019945	DRP-COMPONENT COVER	1
4	4020461	DRP-COMPONENT LEFT SEAT BENCH COVER	1
5	4020462	DRP-COMPONENT RIGHT SEAT BENCH COVER	1
6	4019948	DRP-PANEL LEFT	1
7	4019950	DRP PANEL RIGHT	1
8	4013534	COP-SCREW BUTTON HEAD WITH FLANGE - M6X16 P100 - CL10.9 - BLACK	16
9	4013685	SUP-LOCKNUT WITH FLANGE - M6X1.00 - SIMMONDS	6

No.	Ref.	COP-NUT FLOATING NUT M6 AERO3D M6 1ECEFL001M6	Qty.
A	4013810	COP-NUT FLOATING NUT M6 AERO3D M6 1ECEFL001M6	10
B	4016946	COP-RIVET M3X6 FLAT HEAD	20

## 13.8.2.2 INTERIOR TRIM – Partition Under Seats

### Composite fuel tank



Same assembly for 4020311 and 4020313



Use sticking base for tiezip to hold the tubes

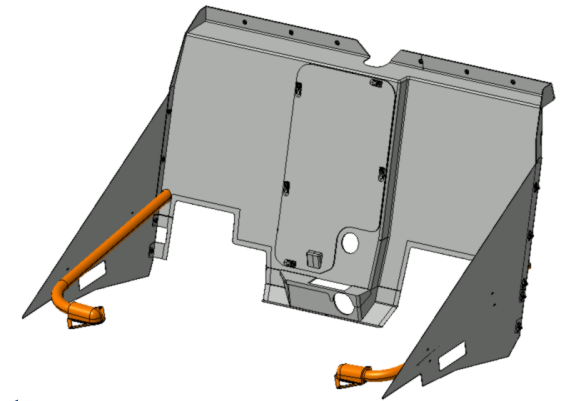

(c)

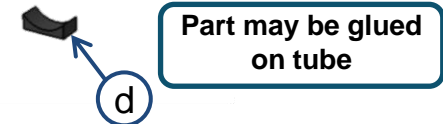
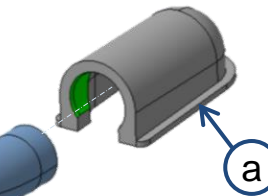
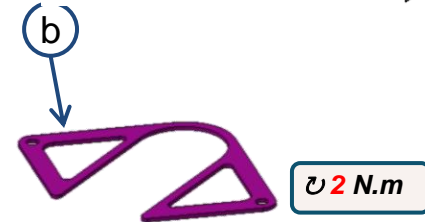

No.	Ref.	Name	Qty.
a	4020276	DRP-COVER FUEL TANK LAT VENTING	2
b	4020309	DRP-COVER RETAINING FORK	2
c	4020281	DRP-COMPONENT FLEX FUEL VENT TRUNKING TUBE	2
d	4021070	DRP-COVER CLOSING FUEL TANK LAT VENTING	2



# 13.8.2.3 INTERIOR TRIM – Partition Under Seats

**Composite fuel tank**

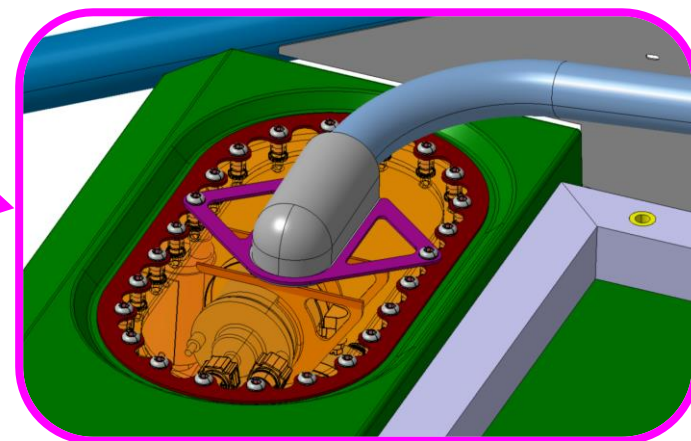
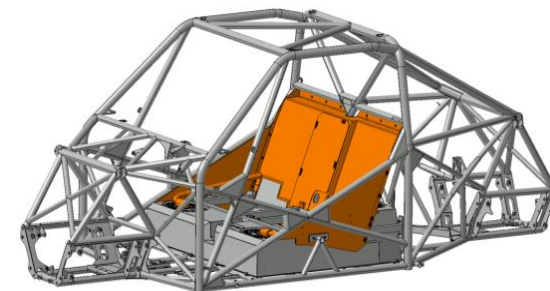
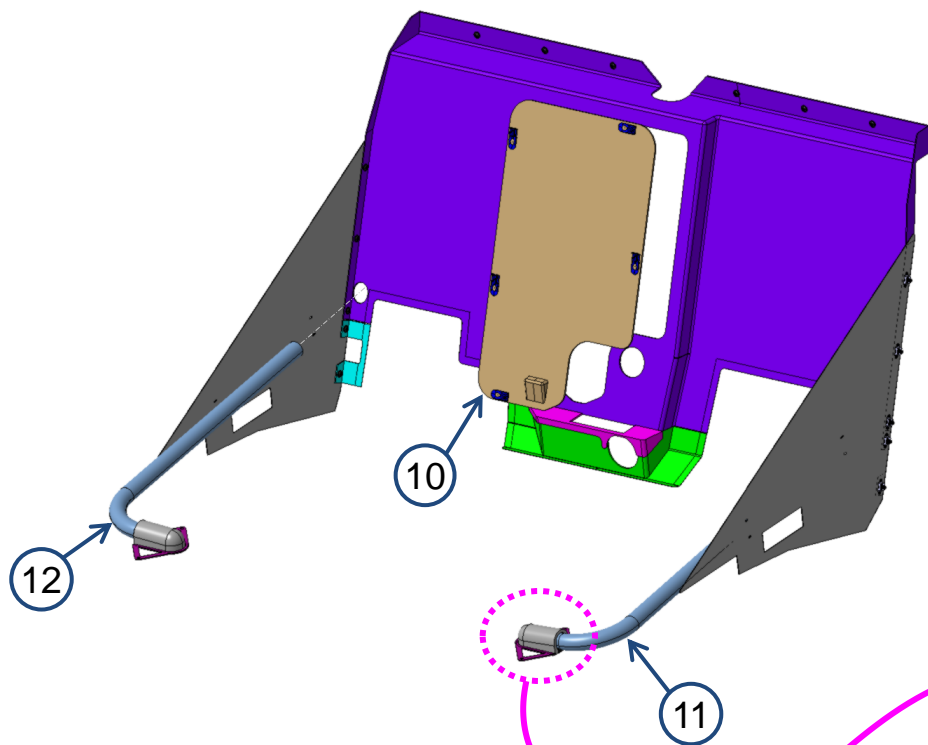

**Use sticking base for tiezip to hold the tubes**

No.	Ref.	Name	Qty.
10	4019947	SASS-TO BE DEFINED INSPECTION HATCH EQUIPPED	1
11	4020311	SASS-TO BE DEFINED COMPONENT FLEX FUEL VENT TRUNKING – LEFT	1
12	4020313	SASS-TO BE DEFINED COMPONENT FLEX FUEL VENT TRUNKING - RIGHT	1

## 13.8.3.1 INTERIOR TRIM – Dashboard fixing

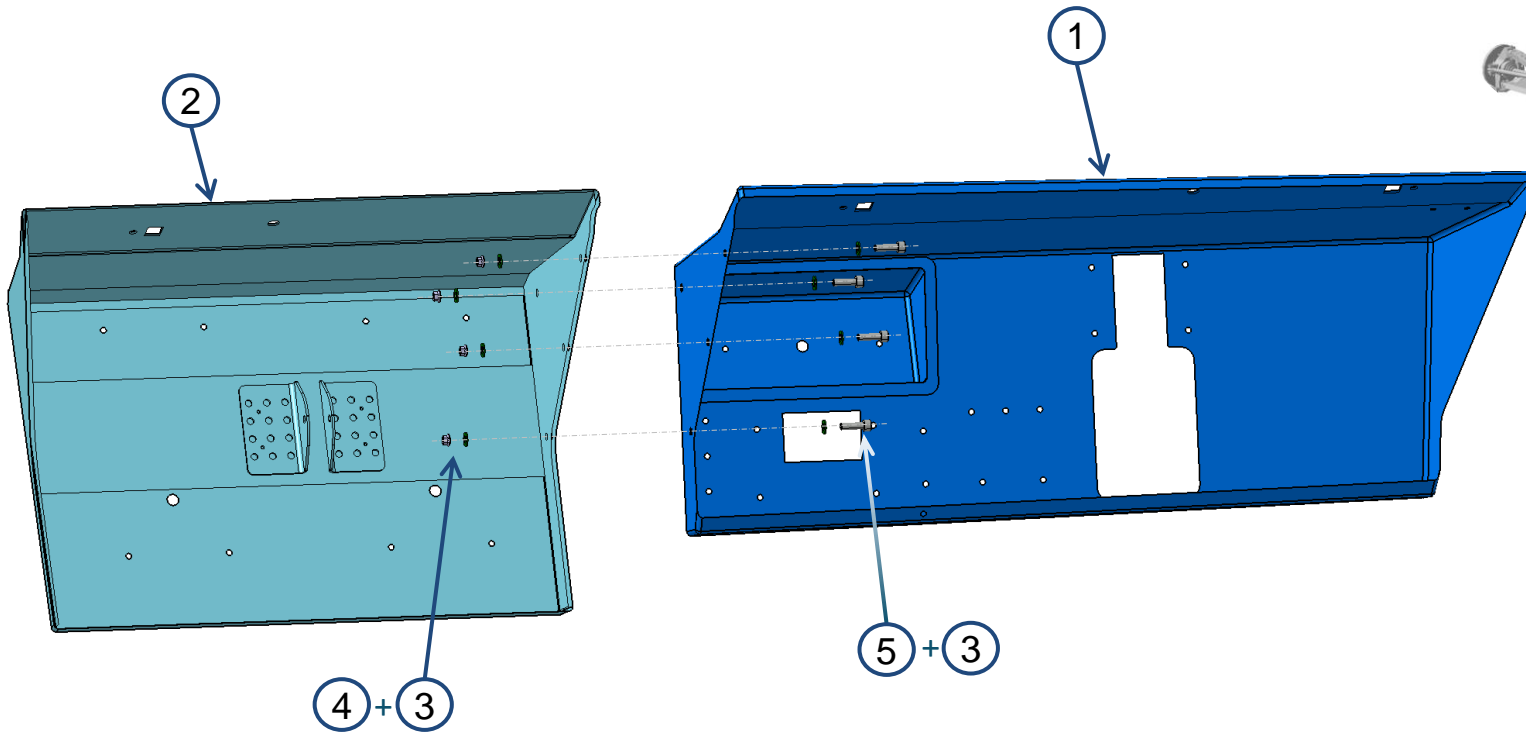
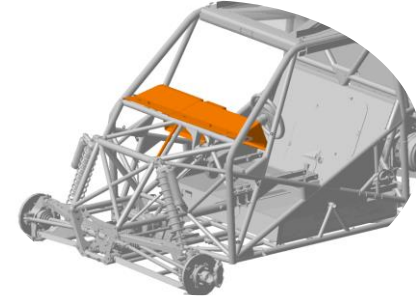

No.	Ref.	Name	Qty.
1	4014427	DRP-COMPONENT DASHBOARD DRIVER COMPOSITE	1
2	4014437	DRP-COMPONENT DASHBOARD COPILOT COMPOSITE	1
3	4009150	SUP-PLAIN WASHER D6XD12X1.2 TYPE Z NFE25-514 A EZ	8
4	4013685	COP-NUT M6X100 SIMMONDS	4
5	4000588	SUP-HEXAGONAL SOCKET CAP SCREW ISO 4762 M6X20-20 P100 CL10.9 A B	4

## 13.8.3.2 INTERIOR TRIM – Dashboard rod



**Set up the power steering BEFORE set up the dashboard**

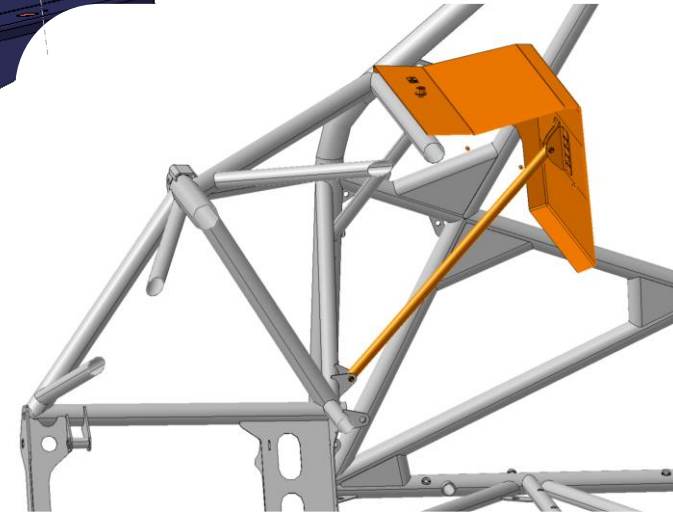
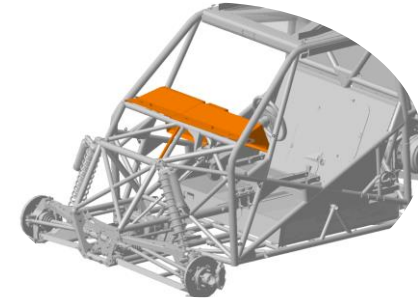
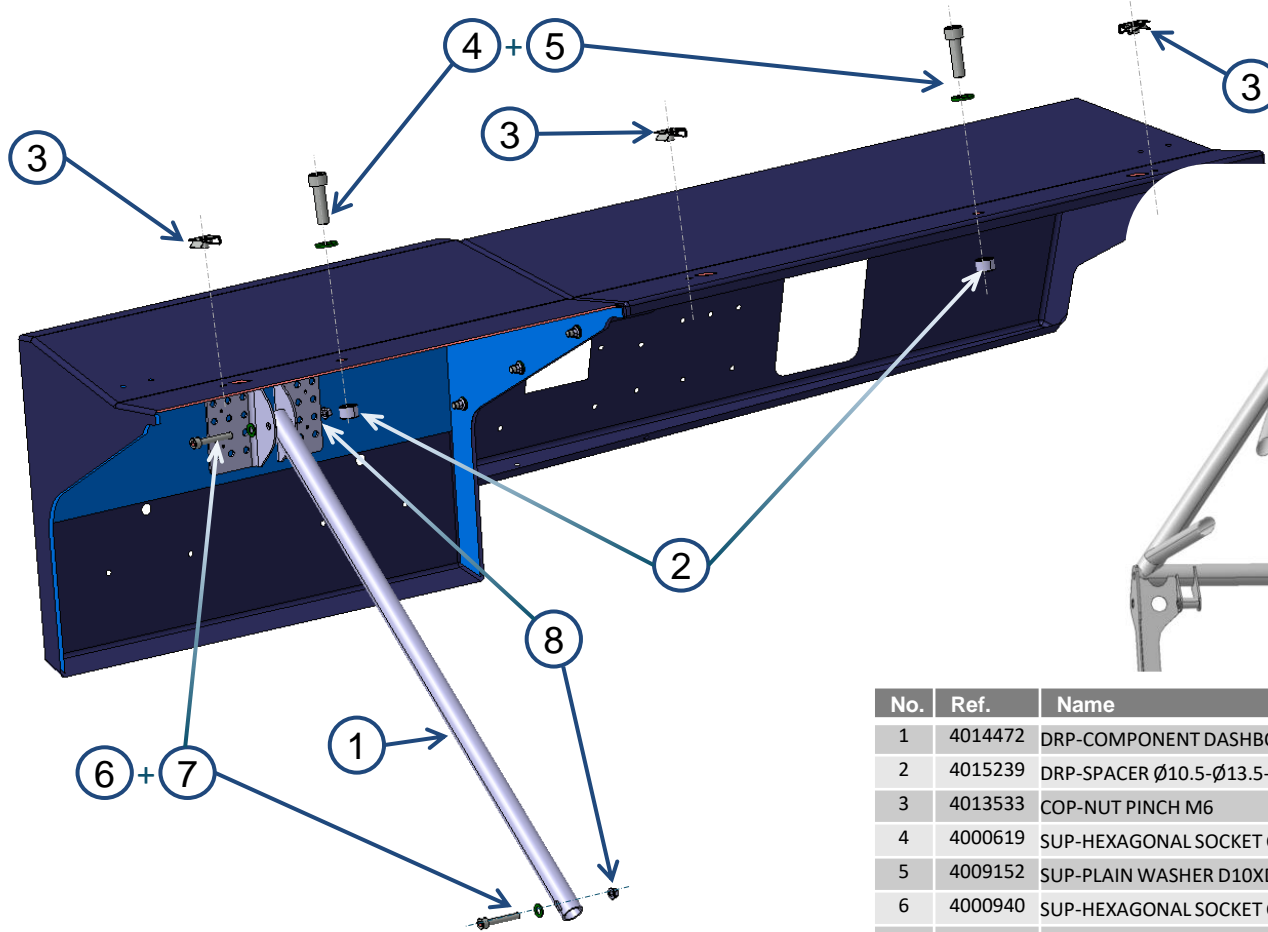

No.	Ref.	Name	Qty.
1	4014472	DRP-COMPONENT DASHBOARD ROD	1
2	4015239	DRP-SPACER Ø10.5-Ø13.5-L10.5	2
3	4013533	COP-NUT PINCH M6	3
4	4000619	SUP-HEXAGONAL SOCKET CAP SCREW ISO 4762 M8X35-28 P125 CL10.9 A B	2
5	4009152	SUP-PLAIN WASHER D10XD20X2 TYPE Z NFE25-514 A EZ	2
6	4000940	SUP-HEXAGONAL SOCKET CAP SCREW ISO 4762 M6X35-24 P100 CL12.9 A B	2
7	4009150	SUP-PLAIN WASHER D6XD12X1.2 TYPE Z NFE25-514 A EZ	2
8	4013685	COP-NUT M6X100 SIMMONDS	2

# 13.9 COCKPIT – Extinguisher

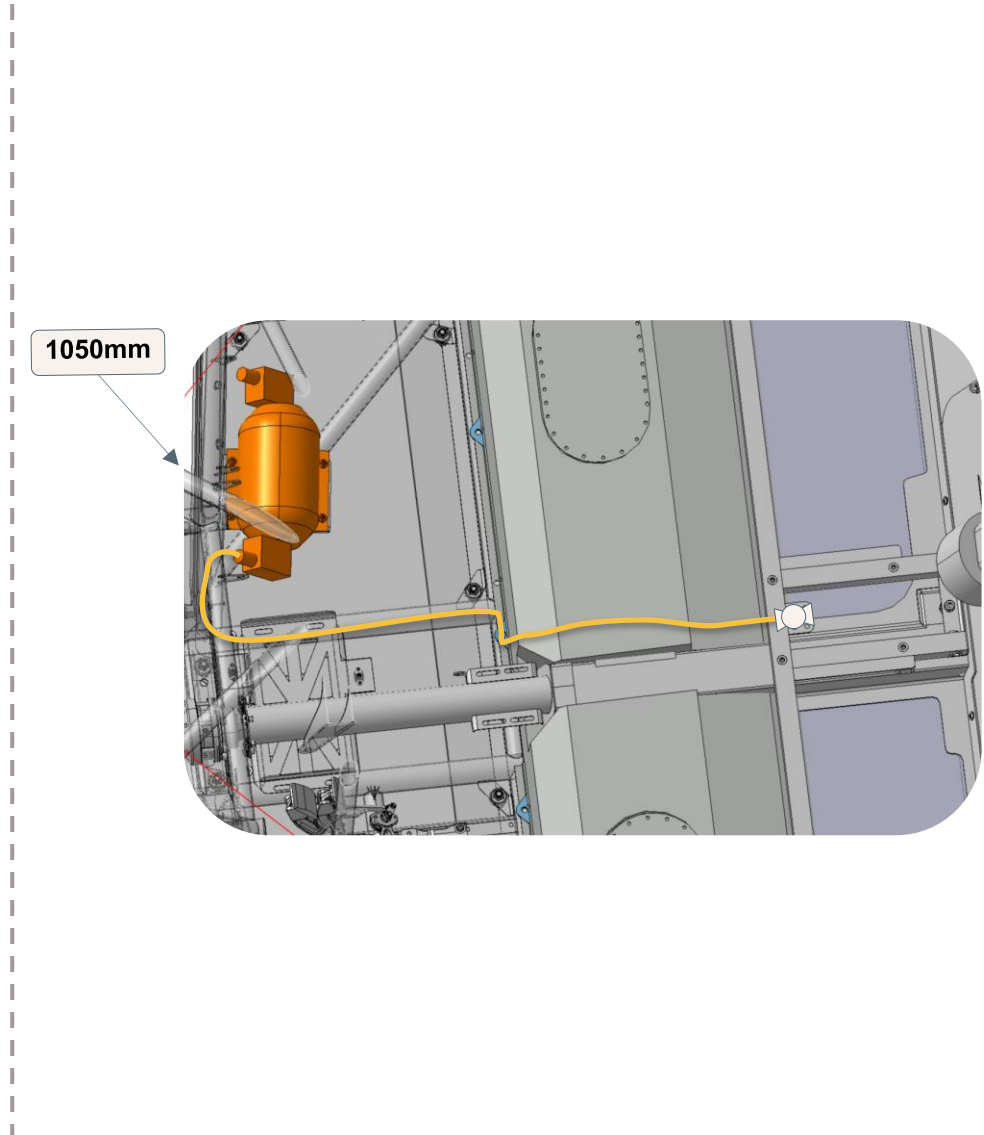
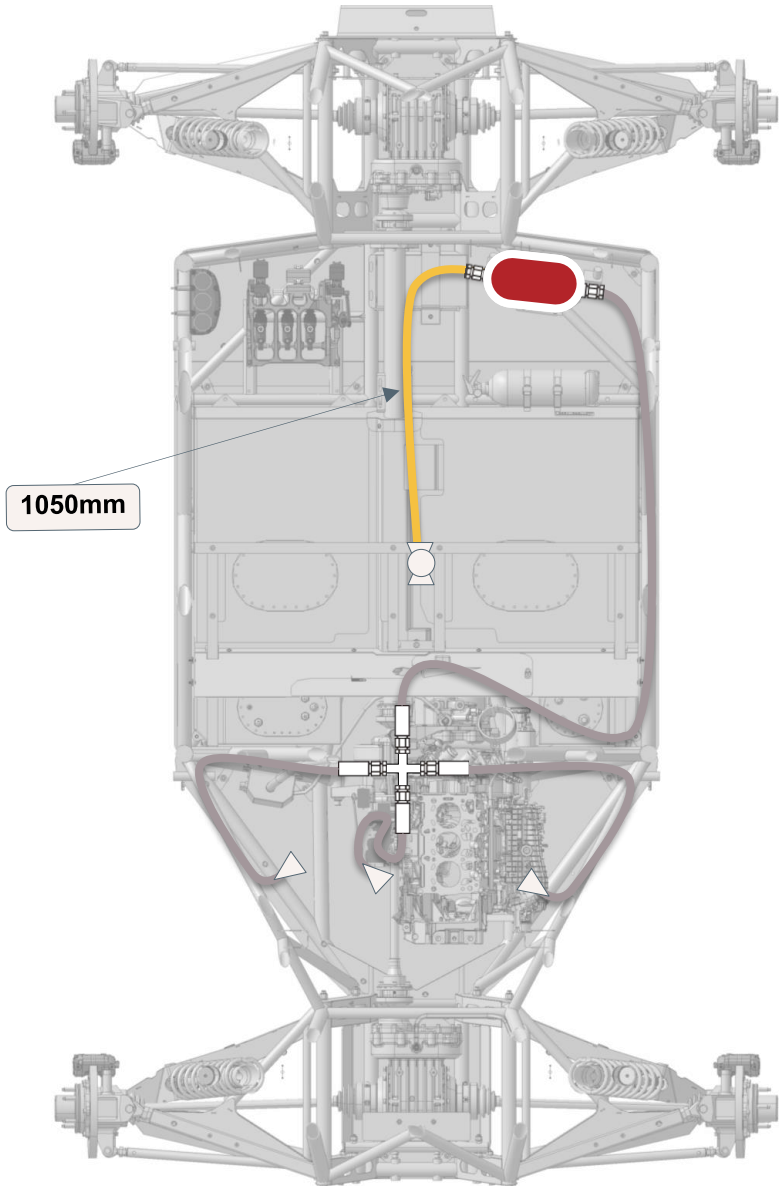

## Section 14

### BODY

# 14. BODY **without windshield**

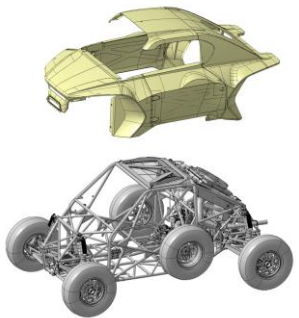
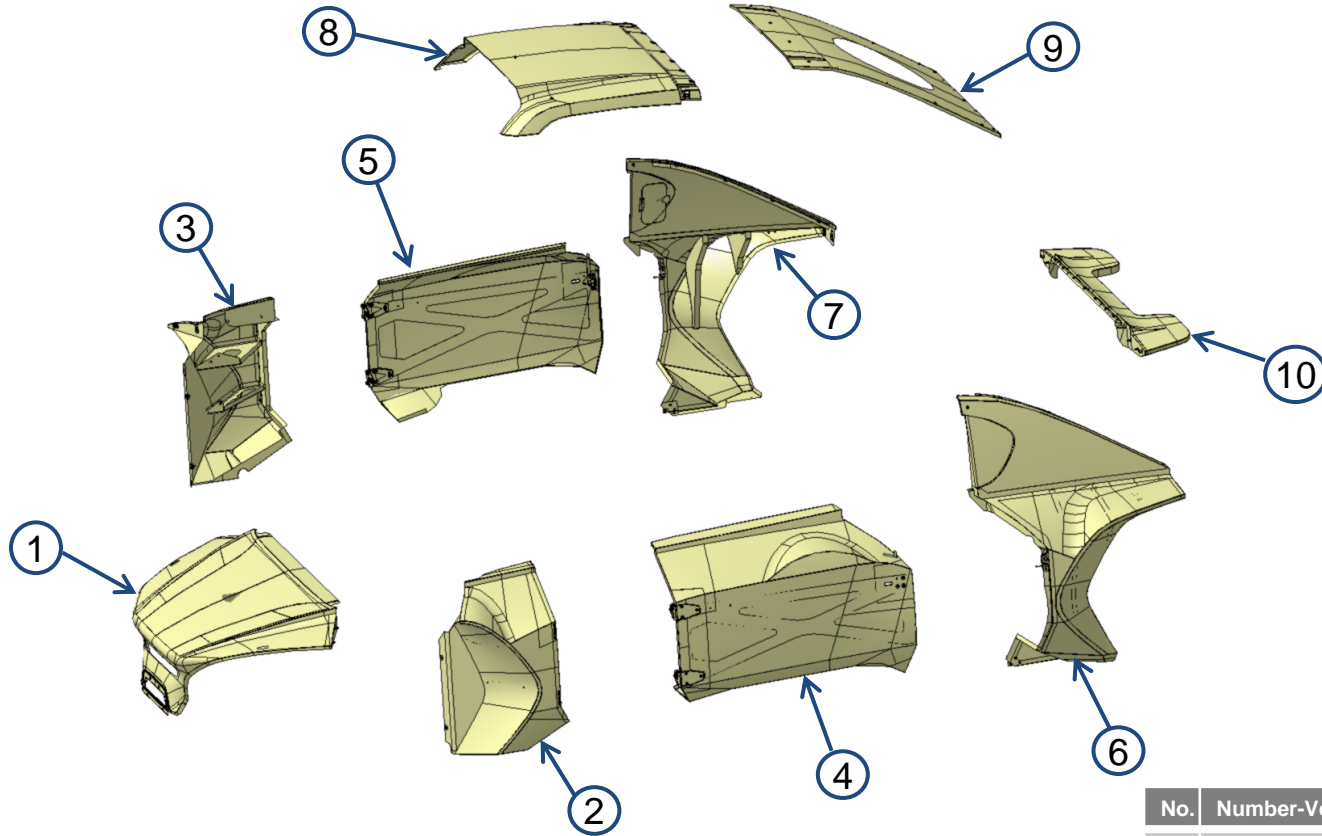
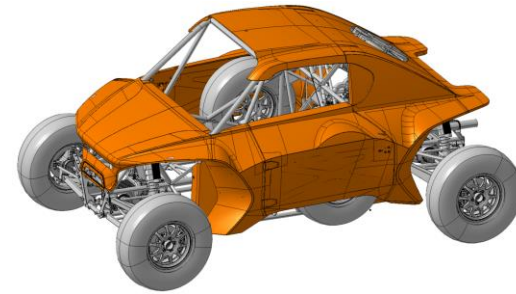

No.	Number-Version-Name	Qty.
1	4014222 - SASS ASM CAR HOOD	1
2	4014226 - SASS ASM FRONT CAR SIDE LEFT	1
3	4014227 - SASS ASM FRONT CAR SIDE RIGHT	1
4	4014229 - SASS ASM DOOR LEFT	1
5	4014230 - SASS ASM DOOR RIGHT	1
6	4014232 - SASS ASM REAR CAR SIDE LEFT	1
7	4014233 - SASS ASM REAR CAR SIDE RIGHT	1
8	4014234 - SASS ASM CAR ROOF	1
9	4014235 - SASS ASM CAR TAILGATE	1
10	4014236 - SASS ASM SPOILER	1

# 14. BODY with windshield

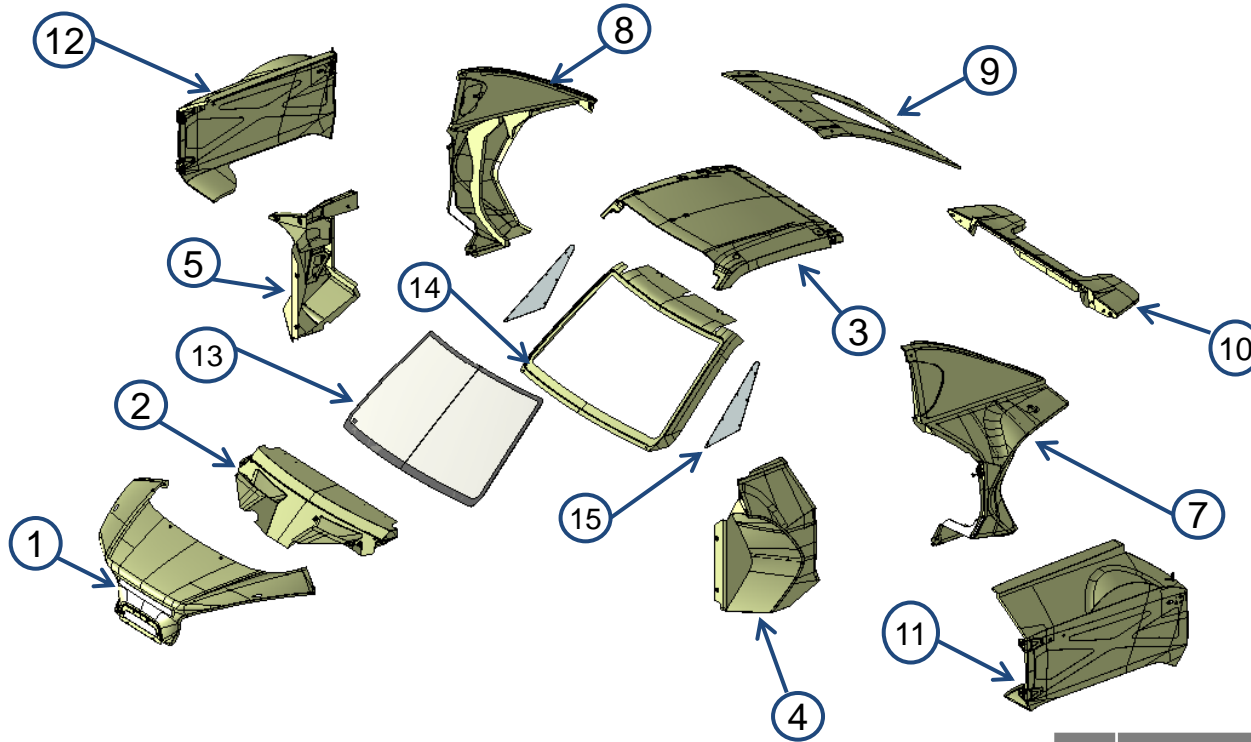
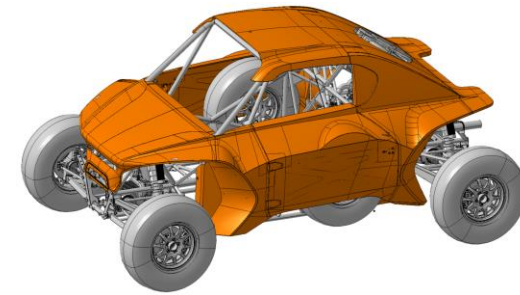

No	Number-Version-Name	Qty
1	4014222 - SASS ASM CAR HOOD COMPATIBLE	1
2	4019810 - SASS ASM LOWER WINDSCREEN BAY	1
3	4014234 - SASS ASM CAR ROOF COMPATIBLE	1
4	4014226 - SASS ASM FRONT CAR SIDE LEFT	1
5	4014227 - SASS ASM FRONT CAR SIDE RIGHT	1
7	4014232 - SASS ASM REAR CAR SIDE LEFT	1
8	4014233 - SASS ASM REAR CAR SIDE RIGHT	1
9	4014235 - SASS ASM CAR TAILGATE	1
10	4014236 - SASS ASM SPOILER	1
11	4014229 - SASS ASM DOOR LEFT	1
12	4014230 - SASS ASM DOOR RIGHT	1
13	4019812 - DRP COMPONENT WINDSCREEN	1
14	4019811 - DRP-COMPONENT WINDSCREEN FRAME	1
15	4020446 - DRP COMPONENT FRONT QUARTER PANEL	2

# 14.3.1 BODY – Front Car Side Left

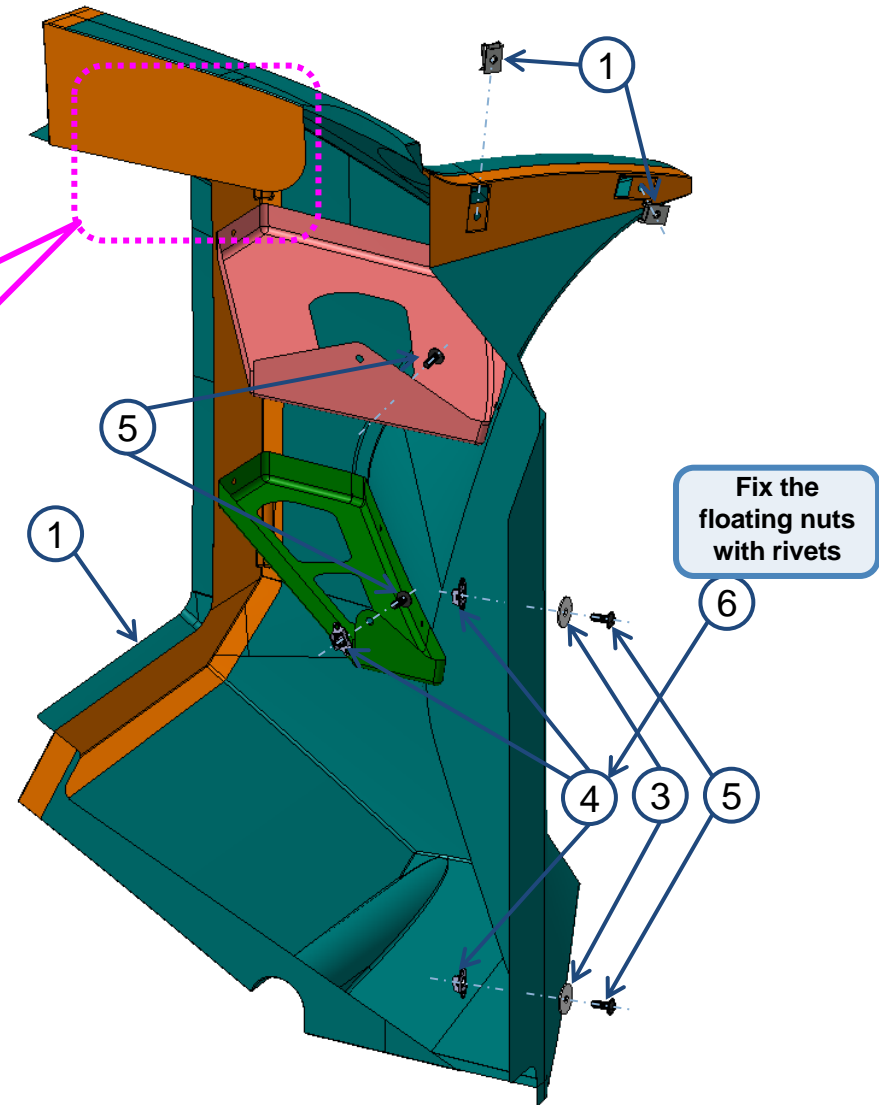
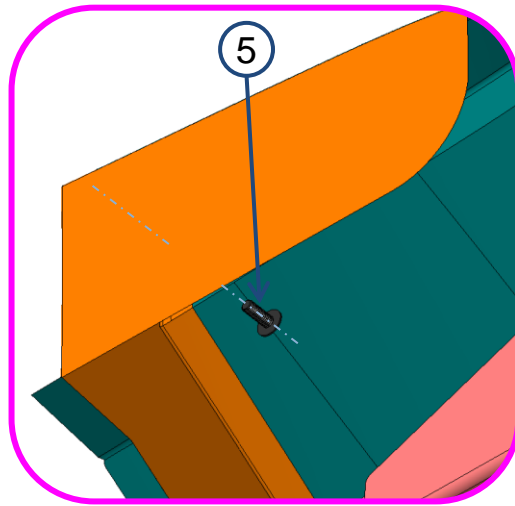
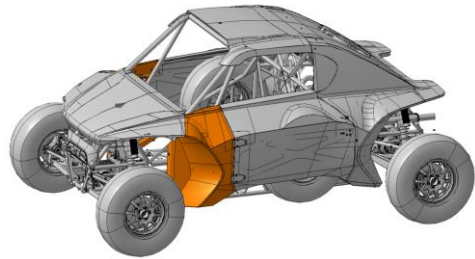

No.	Ref.	Name	Qty.
1	4014245	SASS-PART ASM FRONT CAR SIDE LEFT	1
2	4013533	COP-NUT PINCH M6	2
3	4013818	COP-WASHER M6 BODYWORK WHITE ZINC PLATED	2
4	4013820	COP-NUT FLOATING NUT	3
5	4013534	COP-SCREW BUTTON HEAD WITH FLANGE	5
6	4016996	COP-TO BE DEFINED RIVET	6



# 14.3.2 BODY – Front Car Side Right

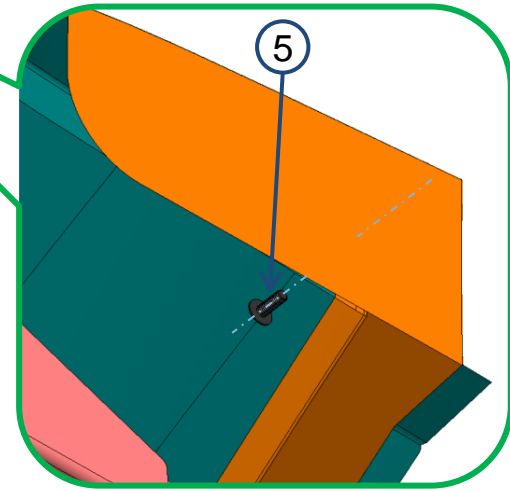
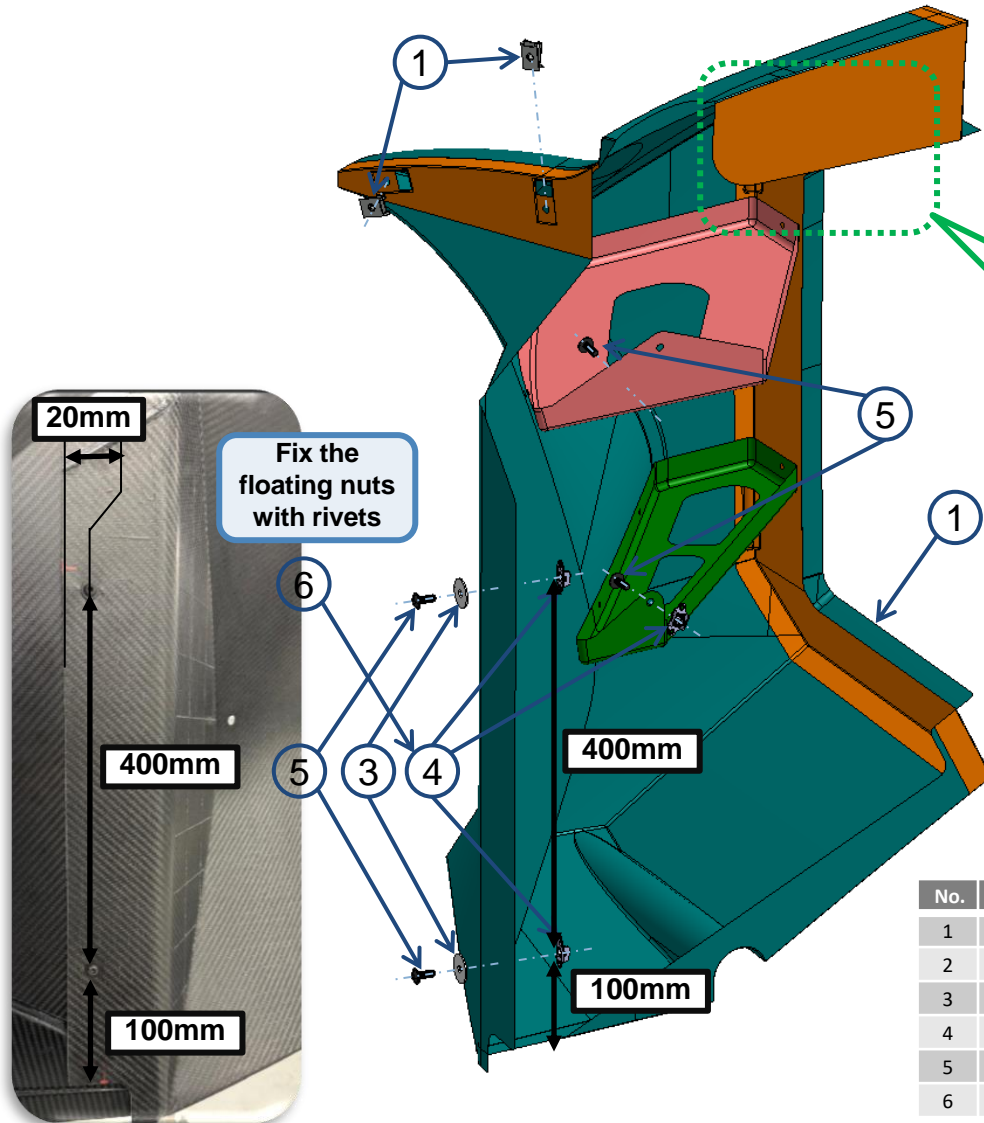
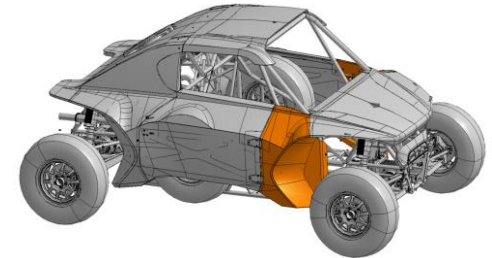

No.	Ref.	Name	Qty.
1	4015262	SASS-PART ASM FRONT CAR SIDE RIGHT	1
2	4013533	COP-NUT PINCH	2
3	4013818	COP-WASHER M6 BODYWORK WHITE ZINC PLATED	2
4	4013820	COP-NUT FLOATING NUT	3
5	4013534	COP-SCREW BUTTON HEAD WITH FLANGE	5
6	4016996	COP-TO BE DEFINED RIVET	6

# 14.4 BODY – Roof **without Windshield**

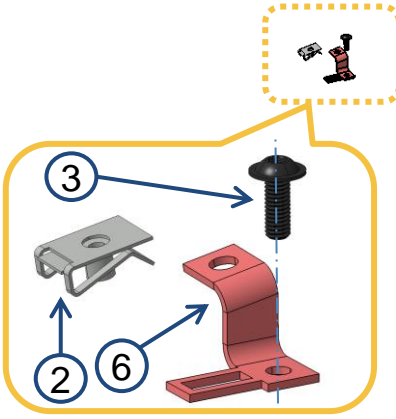
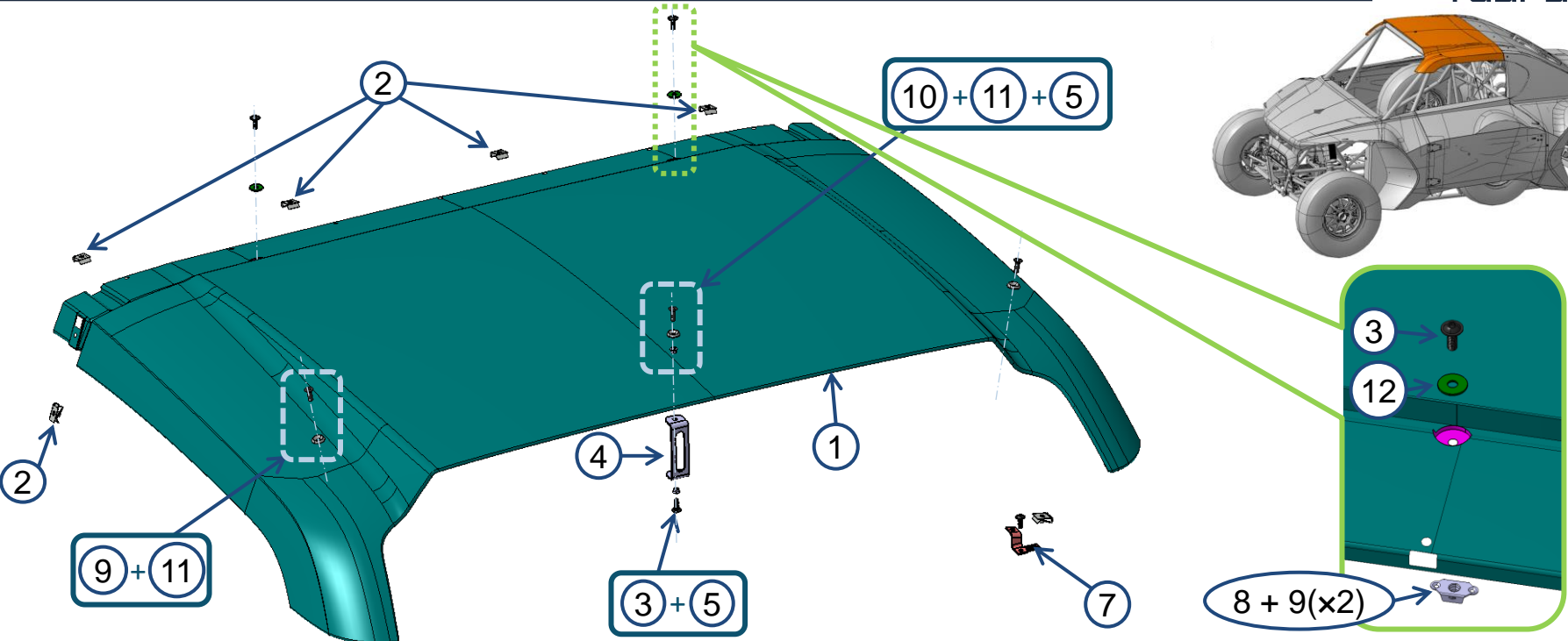
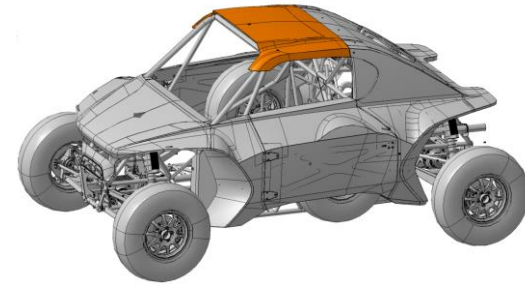

No.	Ref.	Name	Qty.
1	4014238	DRP-COMPONENT ROOF	1
2	4013533	COP-NUT PINCH M6	8
3	4013534	COP-SCREW BUTTON HEAD WITH FLANGE	5
4	4015497	DRP-COMPONENT FRONT SUPPORT CAR ROOF	1
5	4013685	SUP-LOCKNUT WITH FLANGE - M6X1.00 – SIMMONDS	2
6	4015560	DRP-COMPONENT ROOF FRONT RIGHT FIXING	1
7	4015568	DRP-COMPONENT ROOF FRONT LEFT FIXING	1
8	4013820	COP-NUT FLOATING NUT	2
9	4016996	COP-TO BE DEFINED RIVET	4
10	4013841	COP-SCREW TFHC M6X18	3
11	4013844	COP-WASHER COUNTERSUNK ALU M6	3
12	4009189	SUP-PLAIN WASHER	2

# 14.5.1 BODY – Roof with Windshield

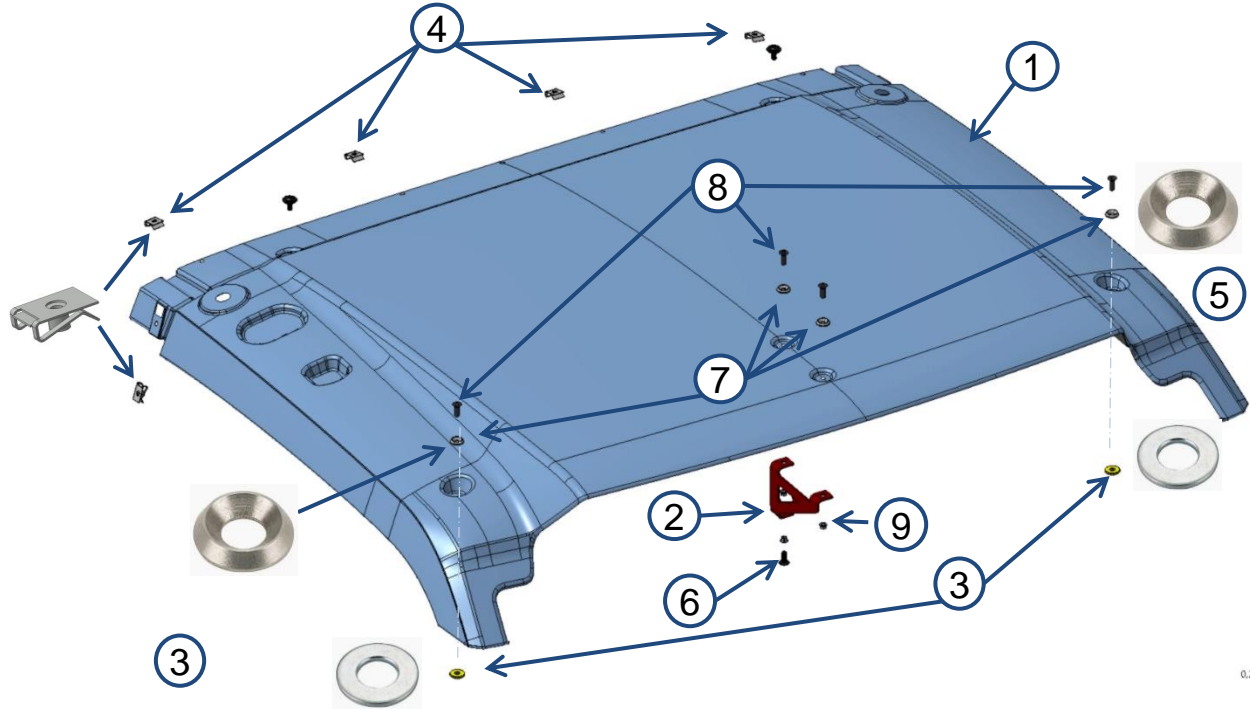
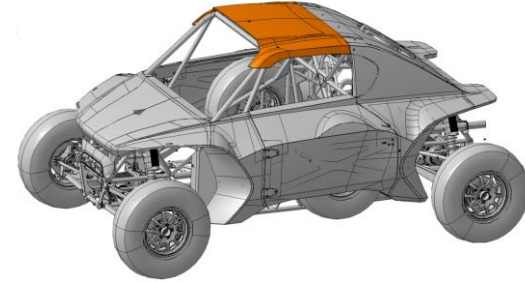

0.259

No.	Ref.	Name	Qty.
1	4019784	DRP-COMPONENT ROOF COMPATIBLE WINDSCREEN	1
2	4019793	DRP-COMPONENT FRONT BRACKET ROOF	1
3	4019786	DRP-SPACER	4
4	4013533	COP-NUT PINCH M6	6
5	4009189	SUP-PLAIN WASHER	2
6	4013534	COP-SCREW BUTTON HEAD WITH FLANGE	3
7	4013844	COP-WASHER COUNTERSUNK ALU M6	4
8	4013841	COP-SCREW TFHC	4
9	4013685	SUP-LOCKNUT WITH FLANGE - M6X1.00 – SIMMONDS	3

## 14.5.2 BODY – Roof with Windshield – Antenna set up

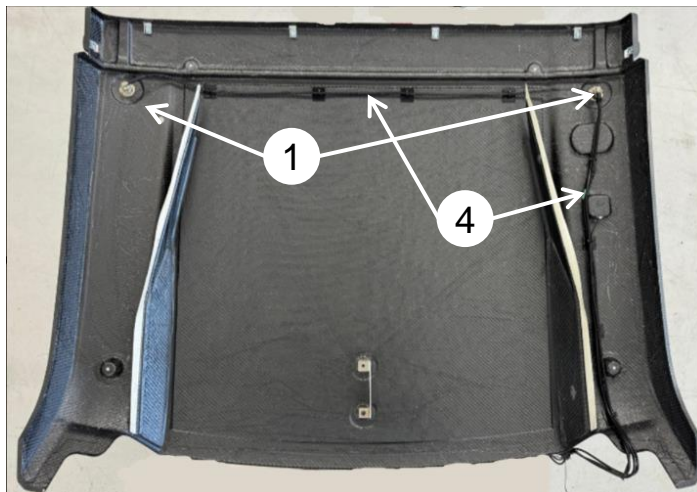
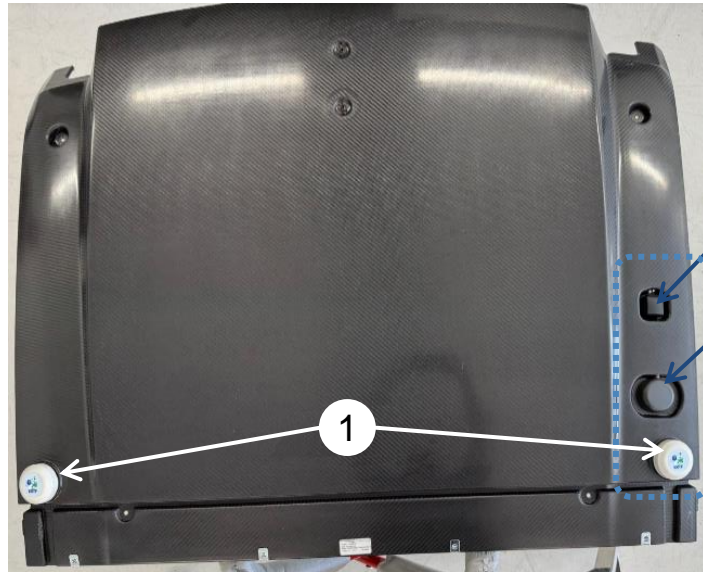
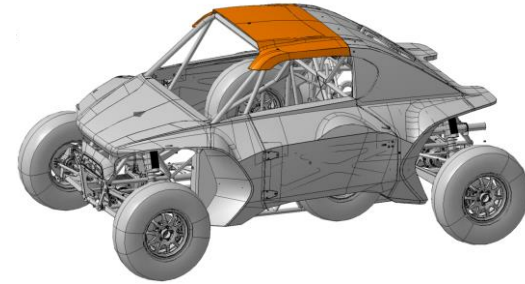

No.	Ref.	Name	Qty.
1	4018454	COP-TO BE DEFINED GPS ANTENNA UNIK	2
2	4018442	COP-TO BE DEFINED MARLINK GPS ANTENNA	1
3	4018441	COP-TO BE DEFINED IRIDIUM ANTENNA	1
4	4018444	COP-TO BE DEFINED GPS ANTENNA CABLE	2

# 14.6.1 BODY – Rear Car Side Left – Hardware

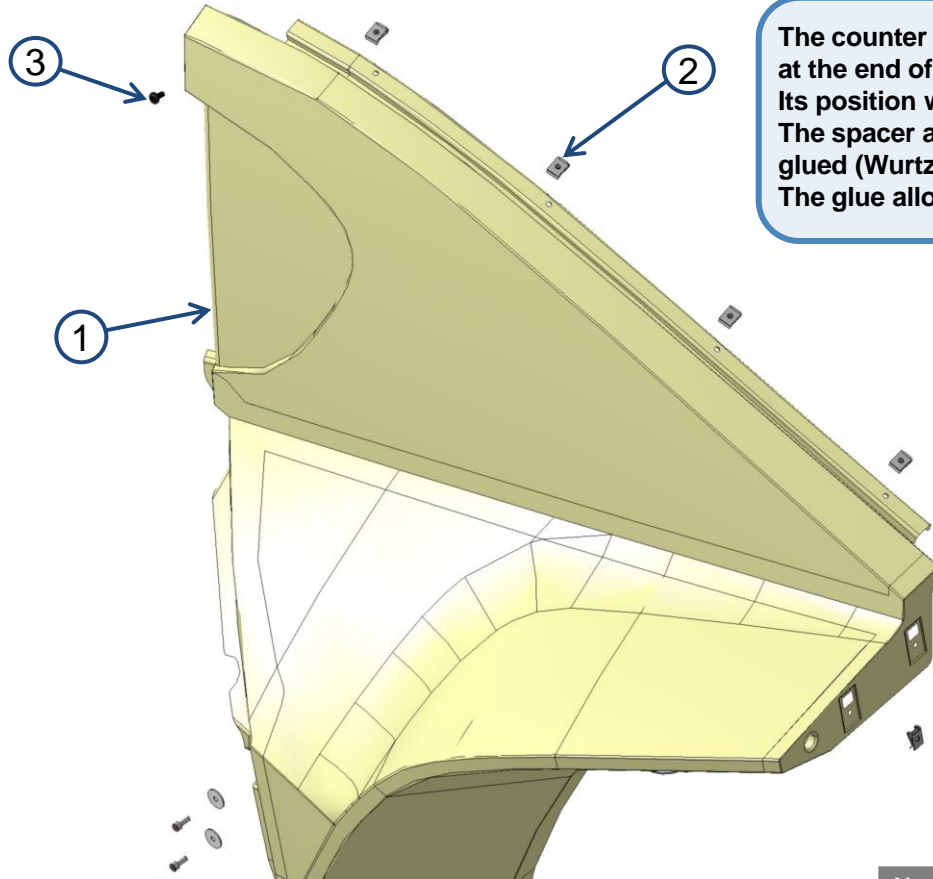
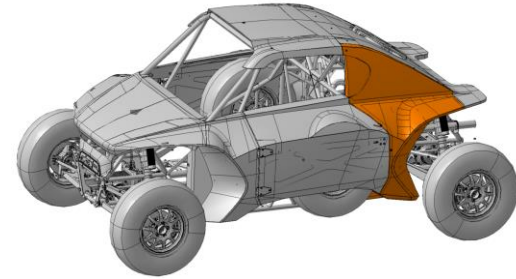

The counter support #4 must be assembled at the end of the body assembly  
 Its position will be adjusted with spacer.  
 The spacer and the counter support will be glued (Wurtz RTV) on the rear wing.  
 The glue allow to conform to the wing shape

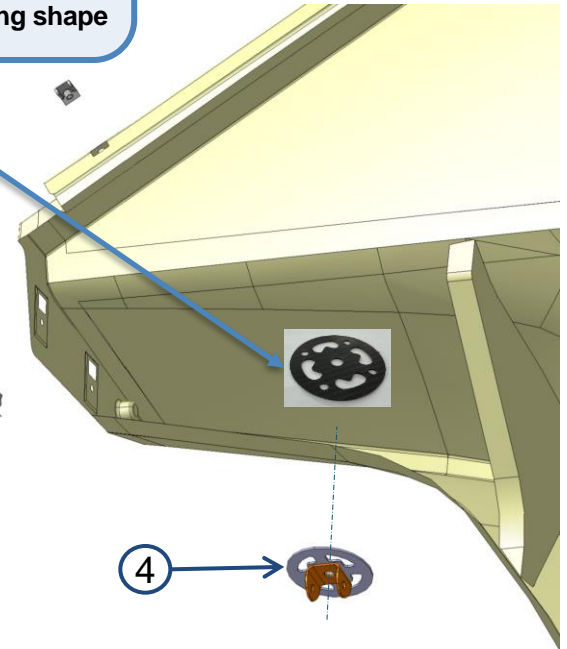

No.	Number-Version-Name	Qty.
1	4014241 - DRP-COMPONENT REAR CAR SIDE LEFT	1
2	4013533 - COP-NUT PINCH M6	7
3	4013534 - COP-SCREW BUTTON HEAD WITH FLANGE - M6X16 P100 - CL10.9 - BLACK	1
4	4014114 - SASS-COMPONENT ASM COUNTER SUPPORT REAR WING	1

# 14.6.2 BODY – Rear Car Side Left – Striker pin

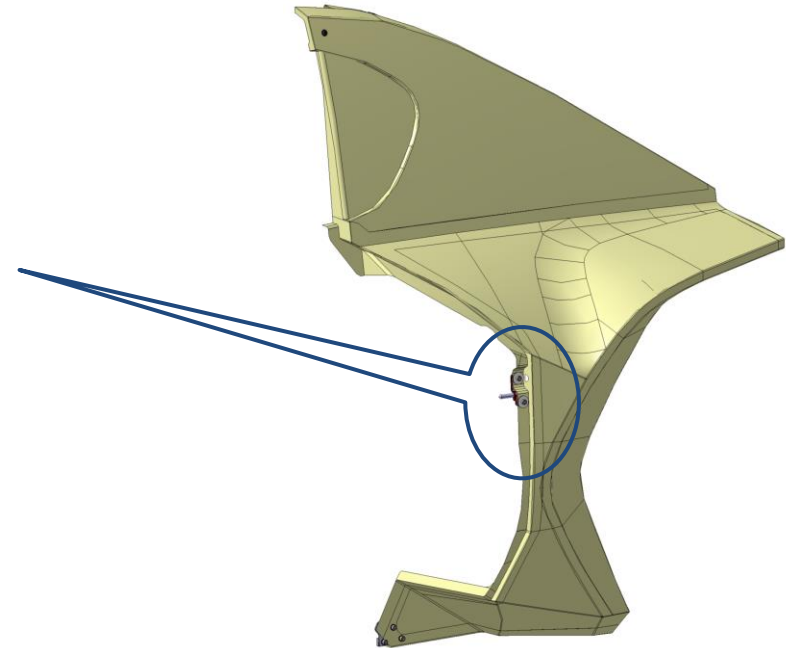
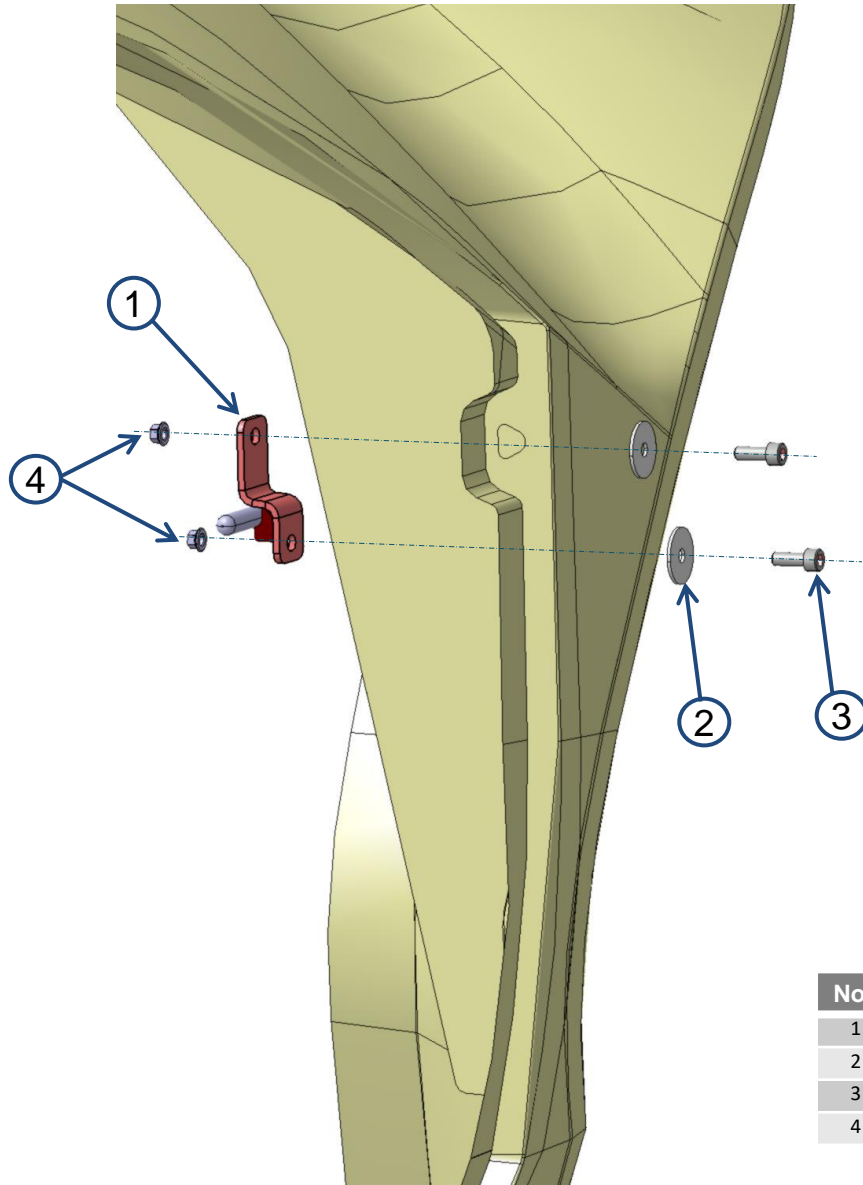
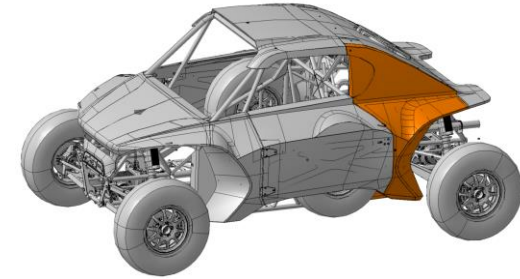

No.	Number-Version-Name	Qty.
1	4015196 - SASS-COMPONENT STRIKER PIN LEFT WELDED	1
2	4013818 - COP-WASHER M6 BODYWORK WHITE ZINC PLATED	2
3	4000934 - SUP-HEXAGONAL SOCKET CAP SCREW ISO 4762 M6X16-16 P100 CL12.9 A B	2
4	4013685 - SUP-LOCKNUT WITH FLANGE - M6X1.00	2

# 14.6.3 BODY – Rear Car Side Left – Lower fixing

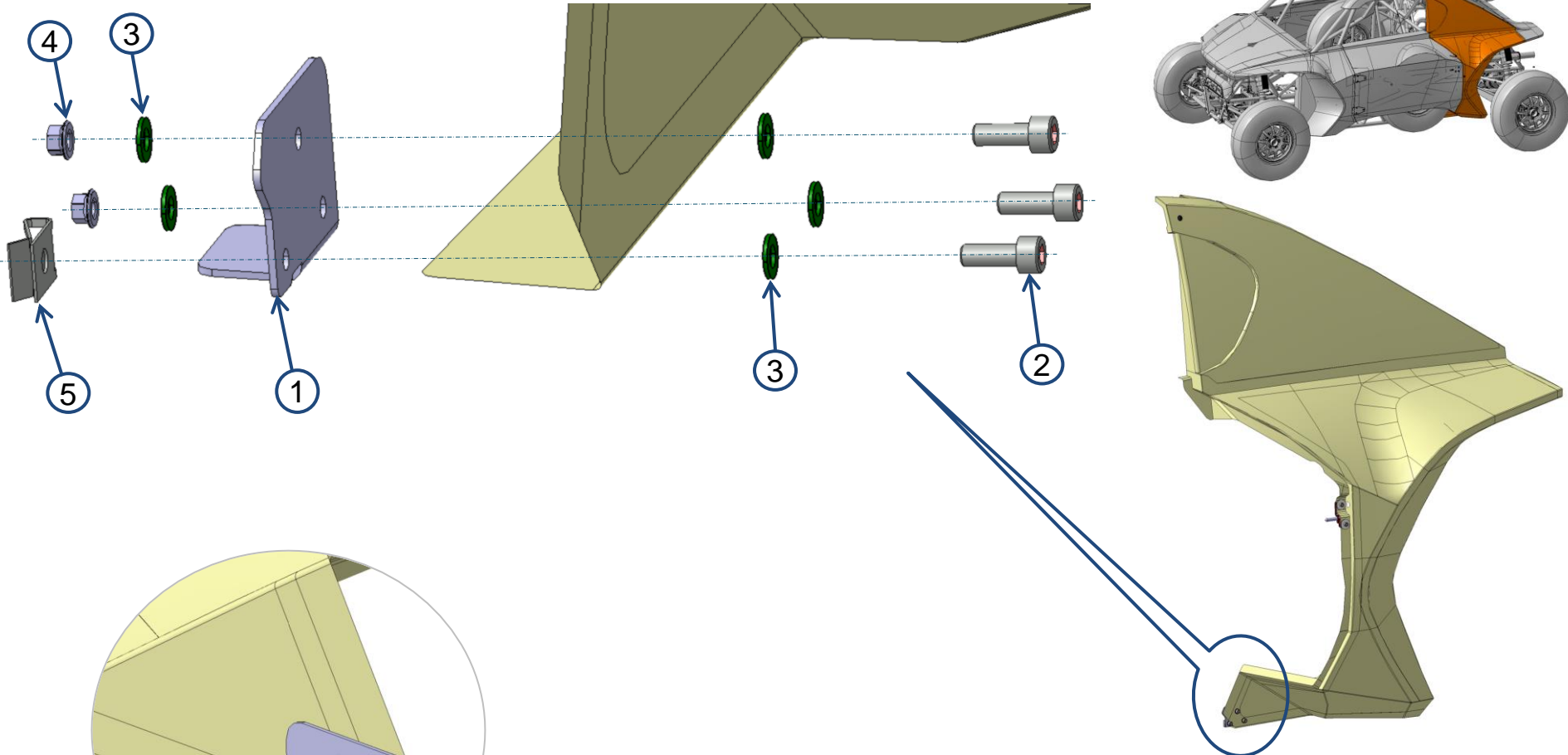

No.	Number-Version-Name	Qty.
1	4014598 - DRP-COMPONENT REAR CAR SIDE LEFT LOWER FIXING	1
2	4000934 - SUP-HEXAGONAL SOCKET CAP SCREW ISO 4762 M6X16-16 P100 CL12.9 A B	3
3	4009150 - SUP-PLAIN WASHER D6XD12X1.2 TYPE Z NFE25-514 A EZ	5
4	4013533 - COP-NUT PINCH M6	1
5	4013685 - SUP-LOCKNUT WITH FLANGE - M6X1.00	2

# 14.64 BODY – Rear Car Side Right – Hardware

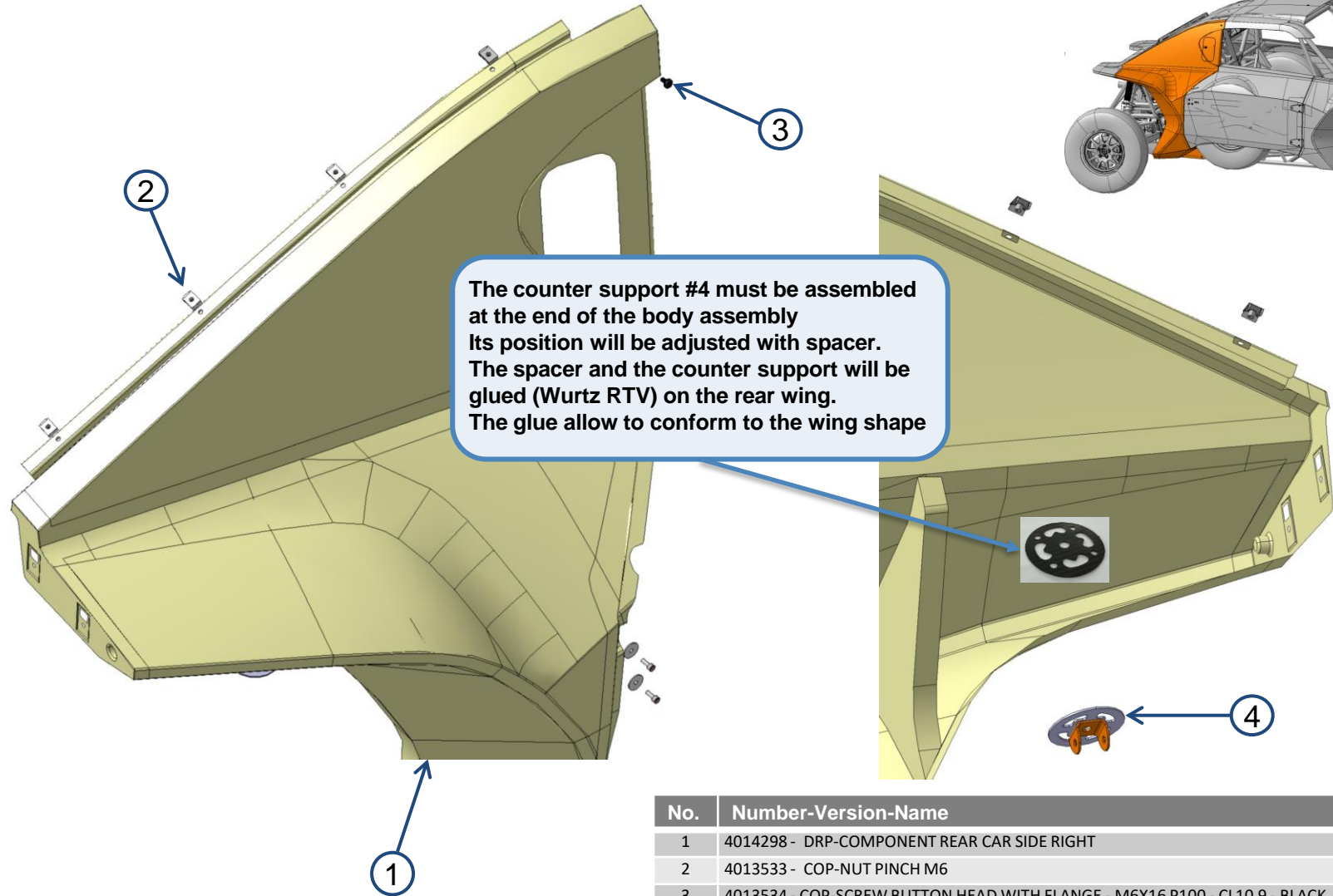
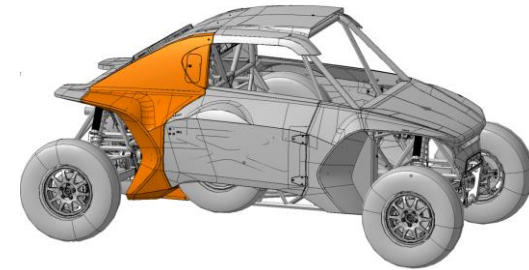

No.	Number-Version-Name	Qty.
1	4014298 - DRP-COMPONENT REAR CAR SIDE RIGHT	1
2	4013533 - COP-NUT PINCH M6	7
3	4013534 - COP-SCREW BUTTON HEAD WITH FLANGE - M6X16 P100 - CL10.9 - BLACK	1
4	4014114 - SASS-COMPONENT ASM COUNTER SUPPORT REAR WING	1



# 14.6.5 BODY – Rear Car Side Right – Striker pin

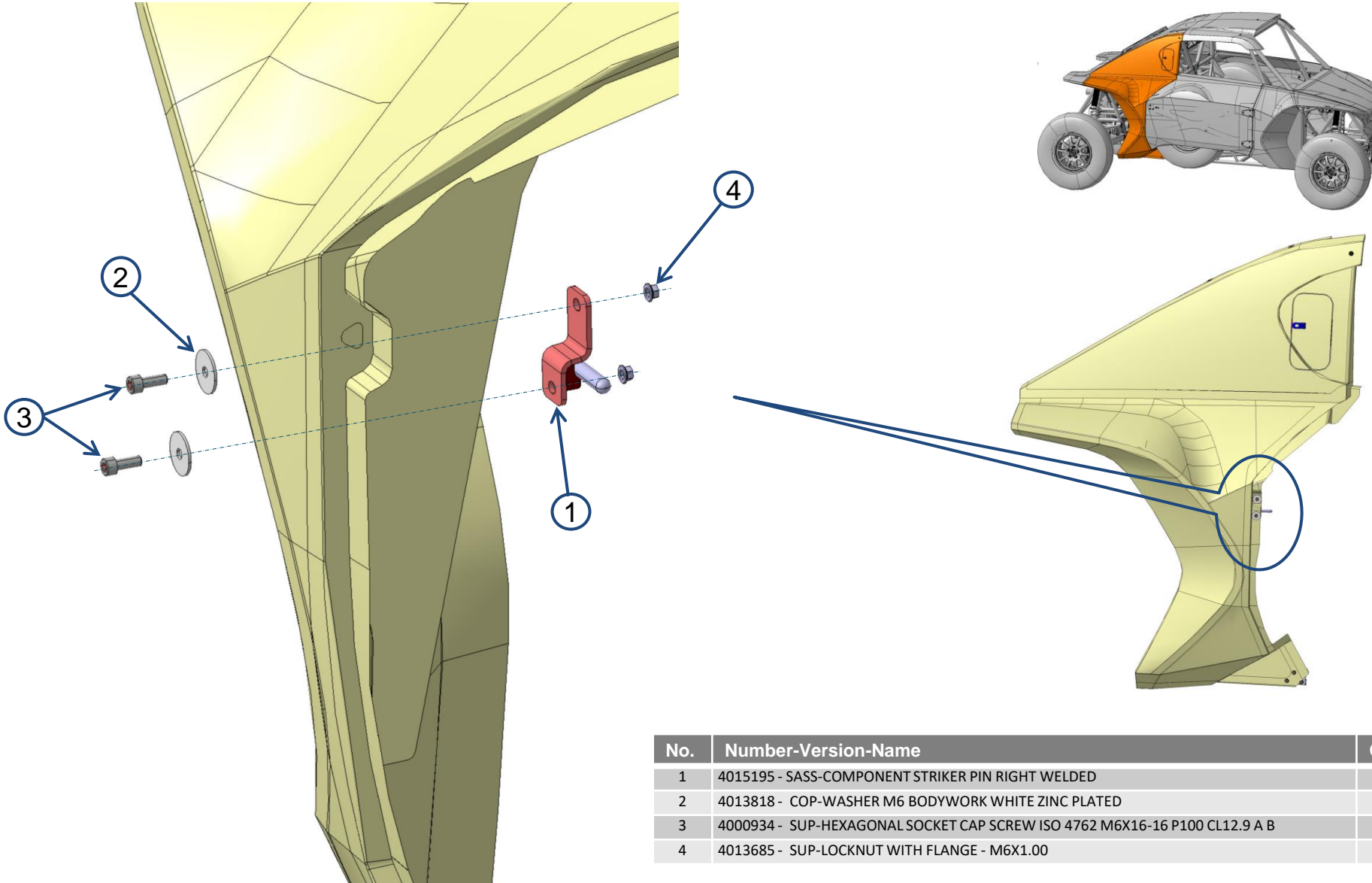
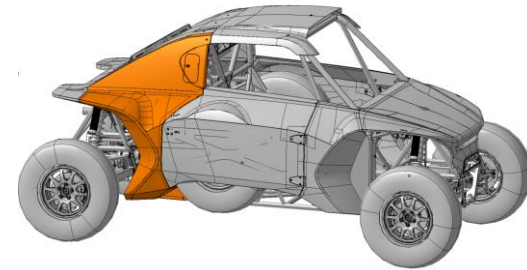

No.	Number-Version-Name	Qty.
1	4015195 - SASS-COMPONENT STRIKER PIN RIGHT WELDED	1
2	4013818 - COP-WASHER M6 BODYWORK WHITE ZINC PLATED	2
3	4000934 - SUP-HEXAGONAL SOCKET CAP SCREW ISO 4762 M6X16-16 P100 CL12.9 A B	2
4	4013685 - SUP-LOCKNUT WITH FLANGE - M6X1.00	2

# 14.6.6 BODY – Rear Car Side Right – Lower fixing

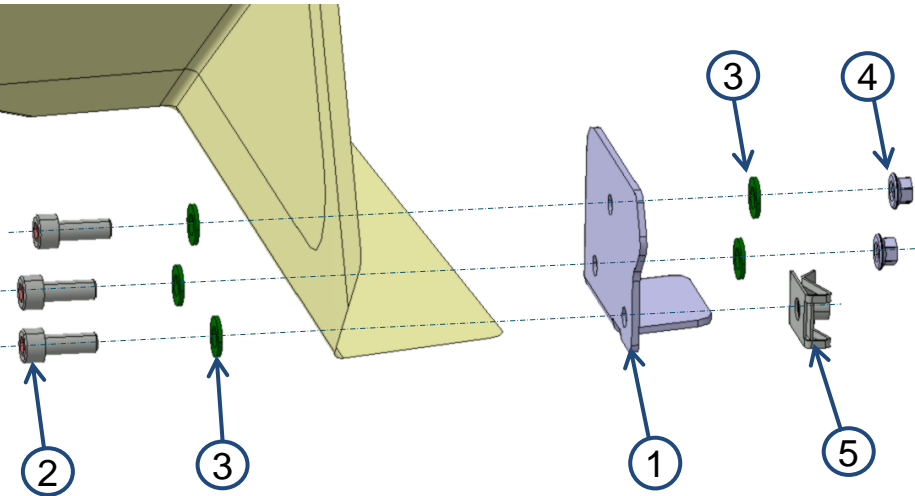
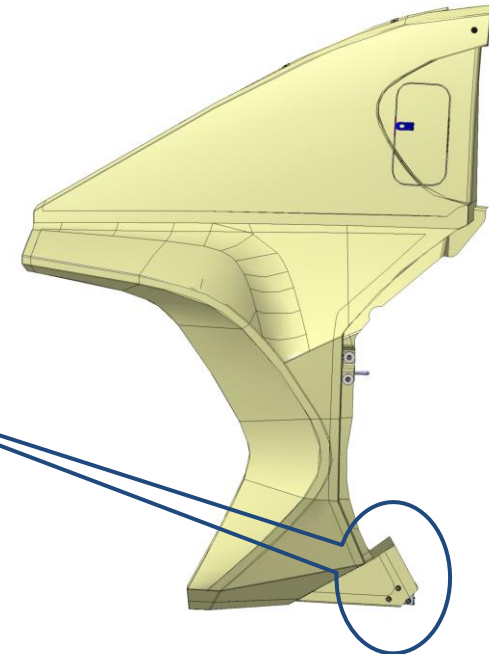
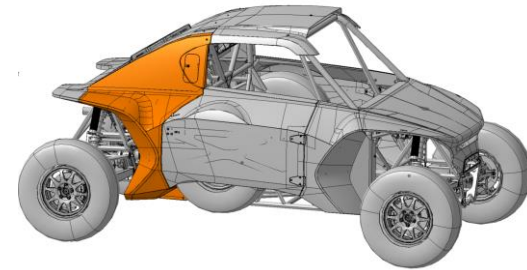

No.	Number-Version-Name	Qty.
1	4015274 - DRP-COMPONENT REAR CAR SIDE RIGHT LOWER FIXING	1
2	4000934 - SUP-HEXAGONAL SOCKET CAP SCREW ISO 4762 M6X16-16 P100 CL12.9 A B	3
3	4009150 - SUP-PLAIN WASHER D6XD12X1.2 TYPE Z NFE25-514 A EZ	5
4	4013533 - COP-NUT PINCH M6	1
5	4013685 - SUP-LOCKNUT WITH FLANGE - M6X1.00	2

# 14.6.7 BODY – Rear Car Side Right – Fuel Hatch

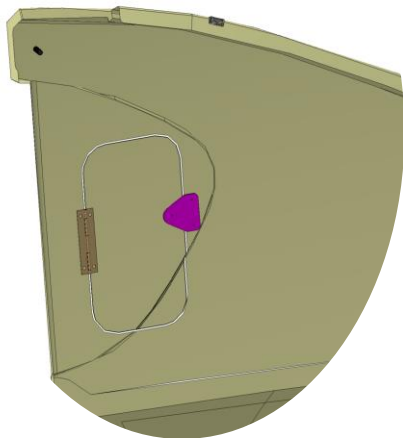
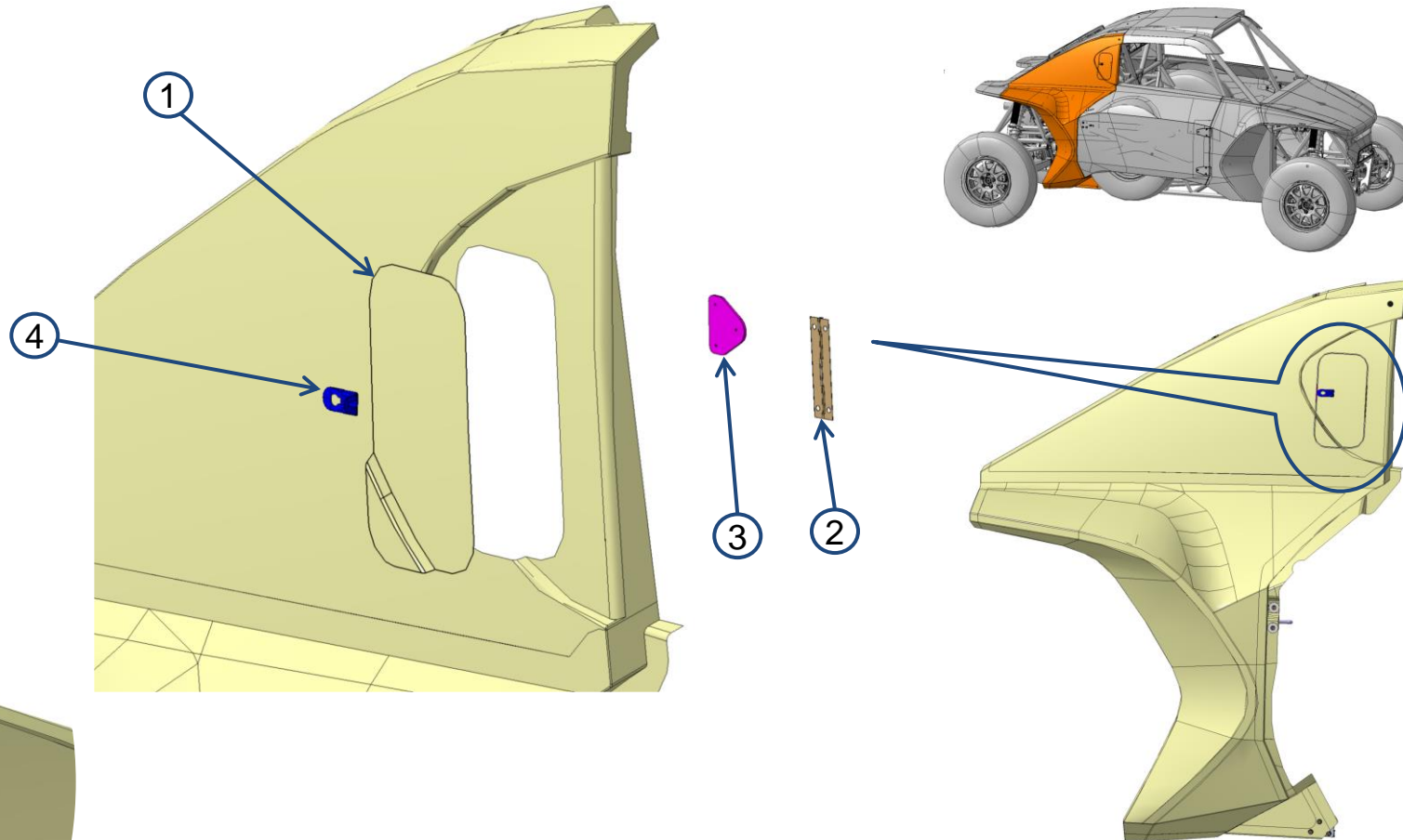
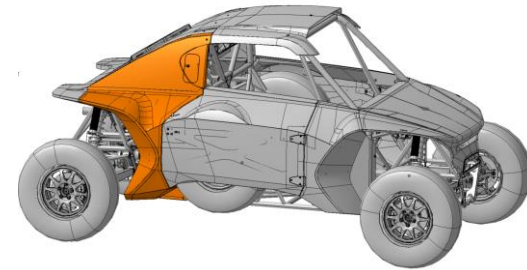

No.	Number-Version-Name	Qty.
1	4015176 - DRP-COMPONENT FUEL HATCH	1
2	4015181 - DRP-COMPONENT HINGE LAITON REWORK FUEL HATCH	1
3	4015269 - DRP-COMPONENT LOCK BRACKET FUEL HATCH	1
4	4014397 - SUP- TARGET FASTER	1

# 14.7 BODY – Car Tailgate – Overview

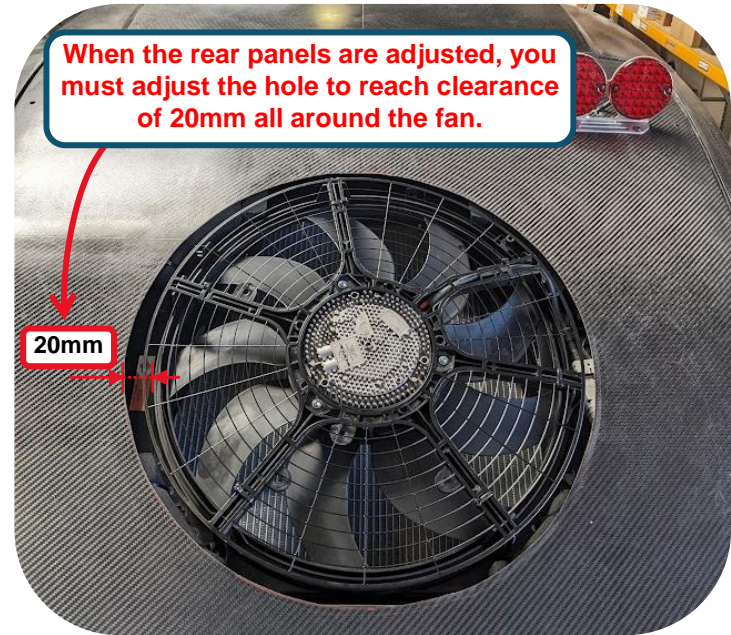
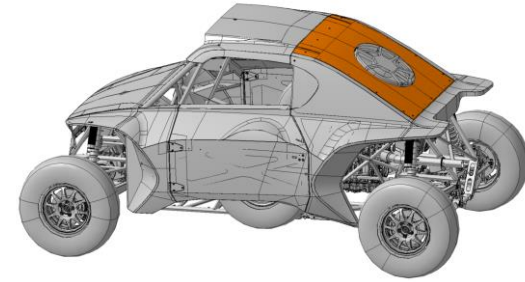
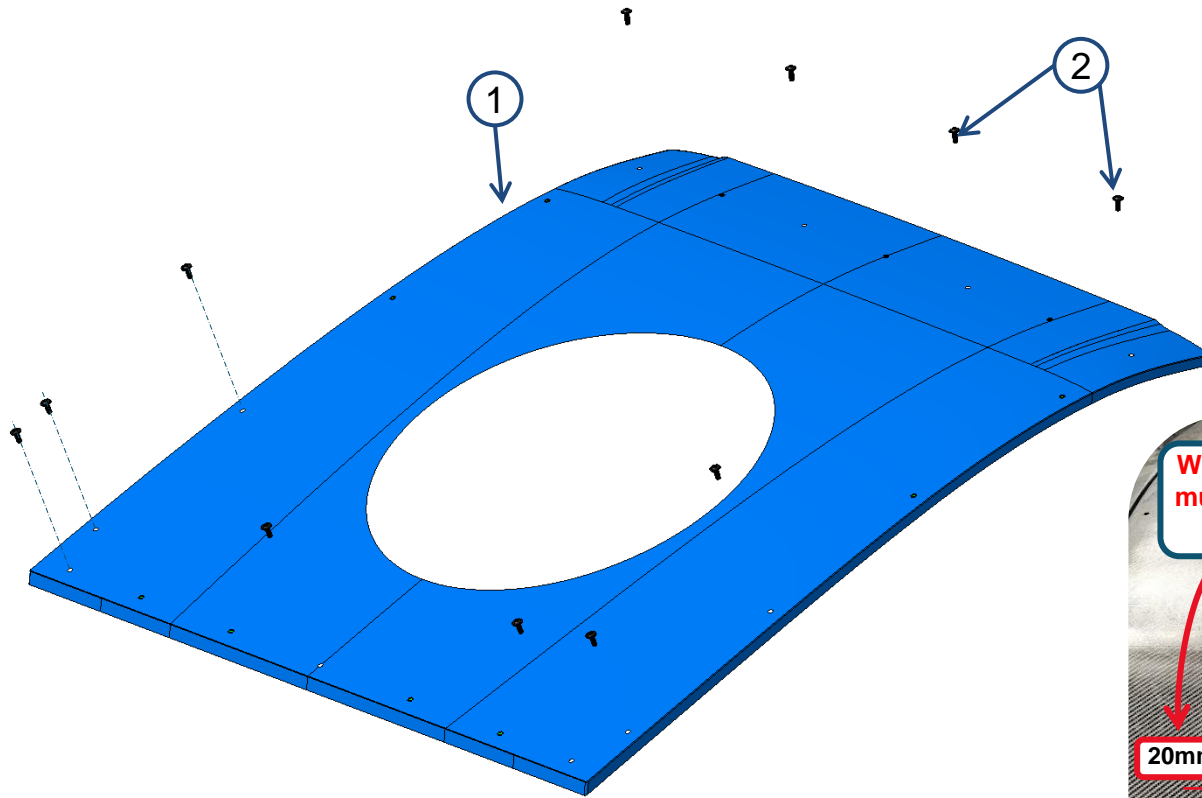

No.	Ref.	Name	Qty.
1	4014240	DRP-COMPONENT PART TAILGATE	1
2	4013534	COP-SCREW BUTTON HEAD WITH FLANGE - M6X16 P100 - CL10.9 – BLACK	11

# 14.8 BODY – Spoiler – Overview

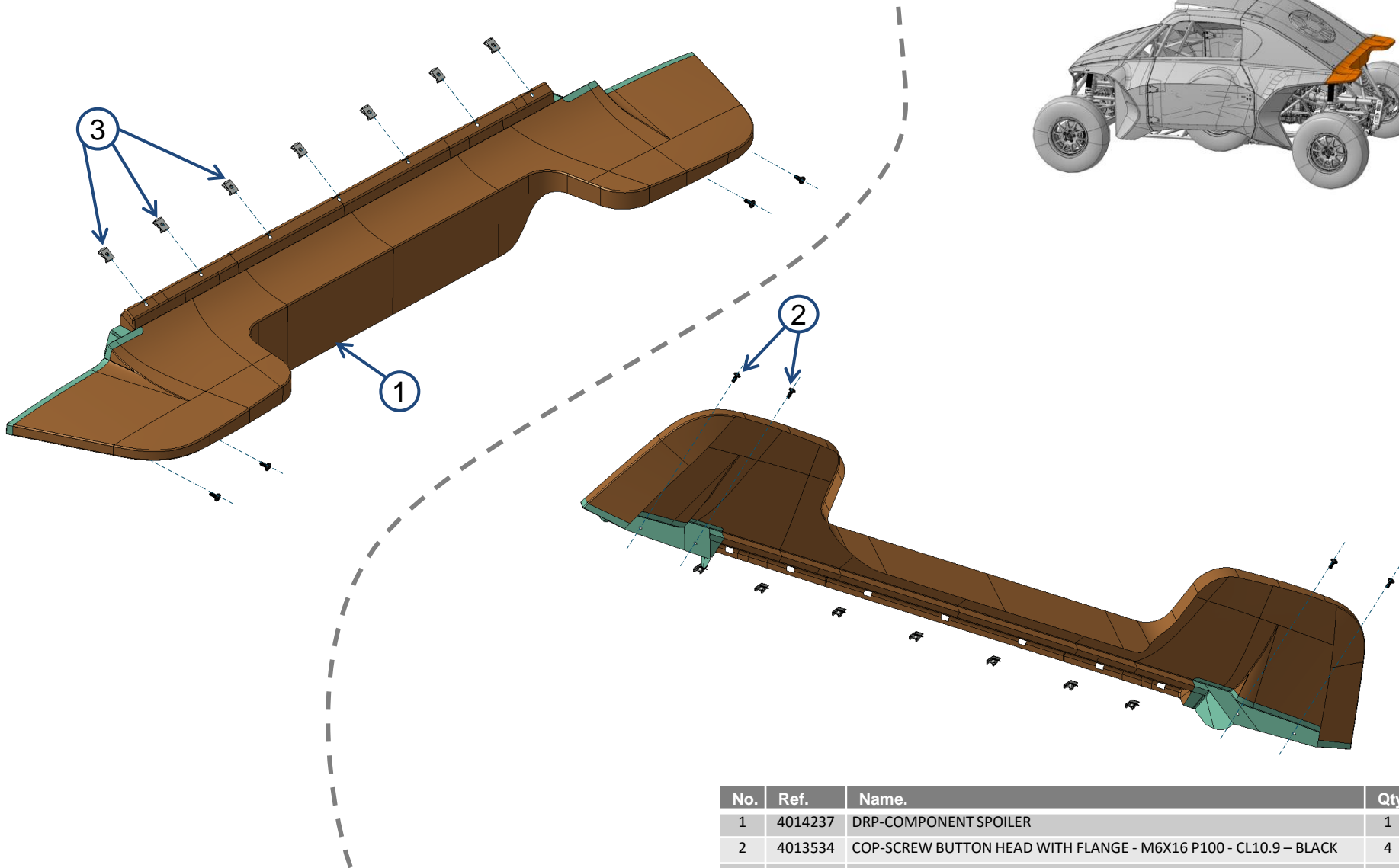
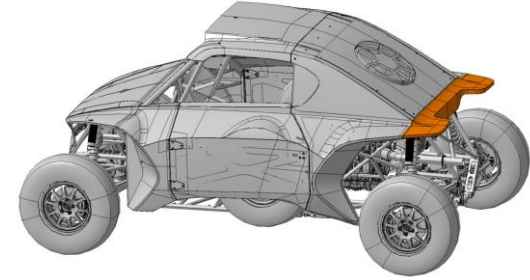

No.	Ref.	Name.	Qty.
1	4014237	DRP-COMPONENT SPOILER	1
2	4013534	COP-SCREW BUTTON HEAD WITH FLANGE - M6X16 P100 - CL10.9 – BLACK	4
3	4013533	COP-NUT PINCH M6	7

# 14.9 BODY – Rear Wings Bracket Right & Left

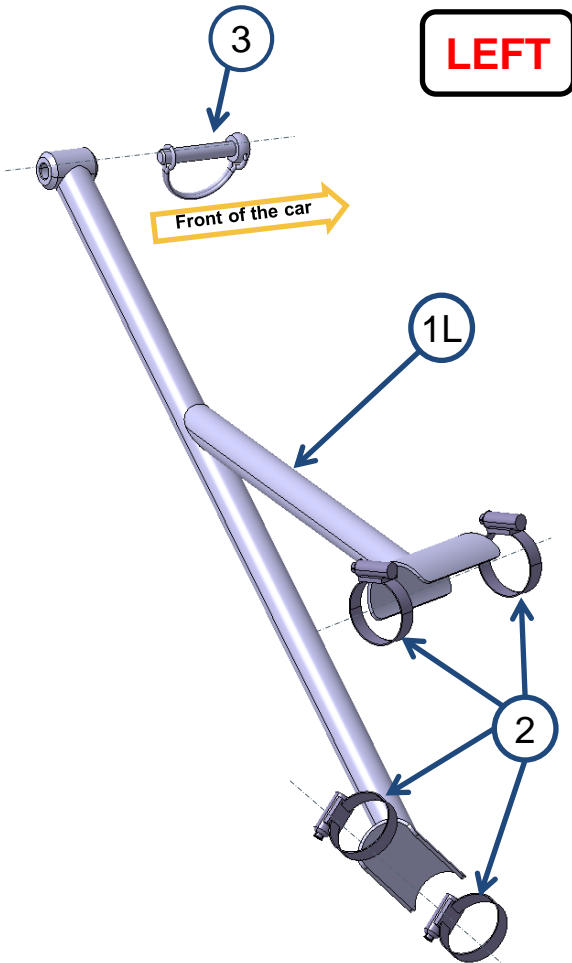

**LEFT**

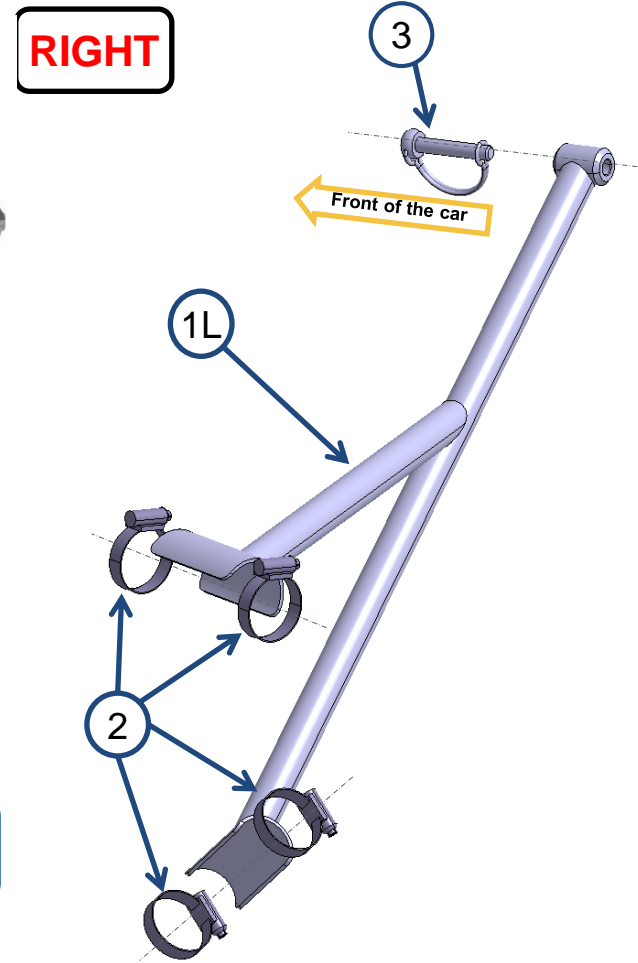
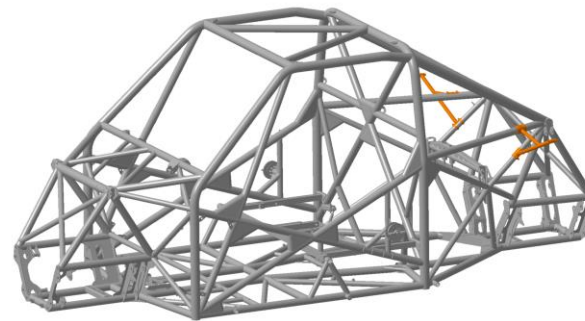

**RIGHT**

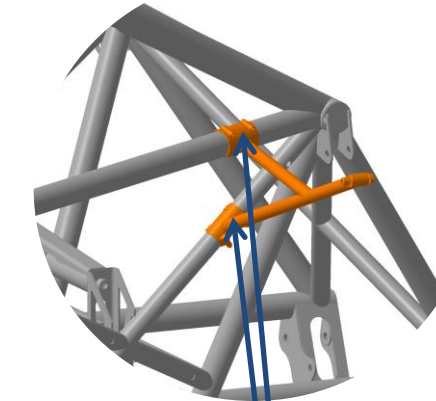

**Chassis protection: Put Helitape under each foot of the wheel support**

No.	Ref.	Name	Qty.
1R	4014802	DRP-COMPONENT BRACKET WELDED REAR WING RIGHT	1
1L	4014748	DRP-COMPONENT BRACKET WELDED REAR WING LEFT	1
2	4021800	COP-HOSE CLAMP WURTZ 14,3MM 40-60 MM	4
3	4018368	COP-TO BE DEFINED FOLDING PIN – Ø8MM – L 38MM	1

# 14.10.1 BODY – Doors – Overview

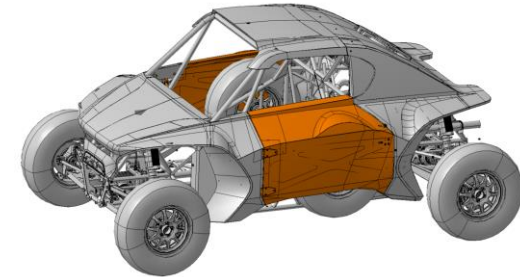

Refer to next page for latch details

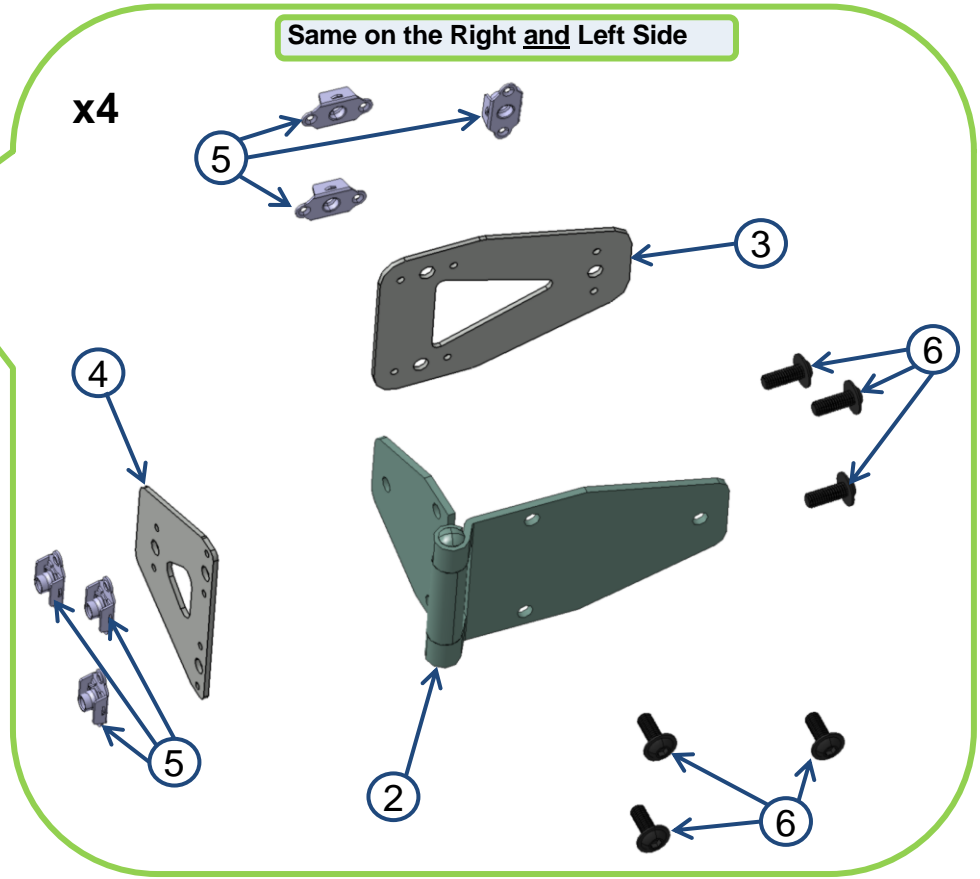
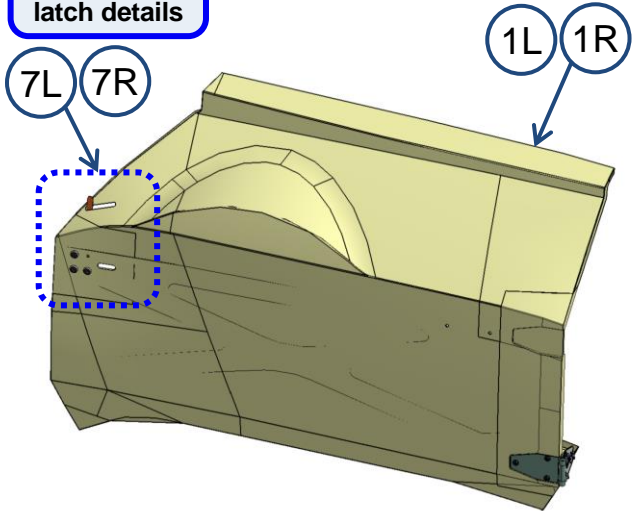

No.	Ref.	Name	Qty.
1L	4014552	DRP-COMPONENT DOOR LEFT	1
1R	4014303	DRP-COMPONENT DOOR RIGHT	1
2	4018086	COP-DOOR HINGE	4
3	4016205	DRP-COMPONENT AGAINST HINGE SUPPORT - FIXED AREA	4
4	4015570	DRP-COMPONENT AGAINST HINGE SUPPORT - FIXED AREA	4
5	4013820	COP-NUT FLOATING NUT M6	24
6	4013534	COP-SCREW BUTTON HEAD WITH FLANGE - M6X16 P100 - CL10.9 - BLACK	24
7L	4015193	SASS-TO BE DEFINED LEFT LATCH CAN-AM EQUIPPED	1
7R	4015194	SASS-TO BE DEFINED RIGHT LATCH CAN-AM EQUIPPED	1

# 14.10.2 BODY – Doors – Latch

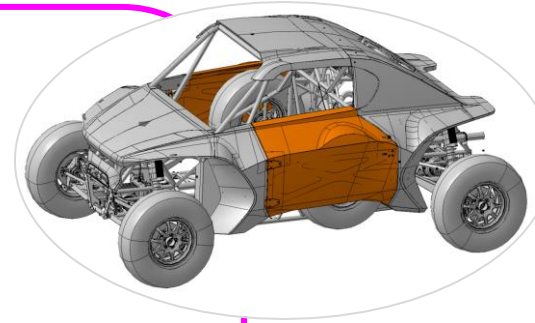
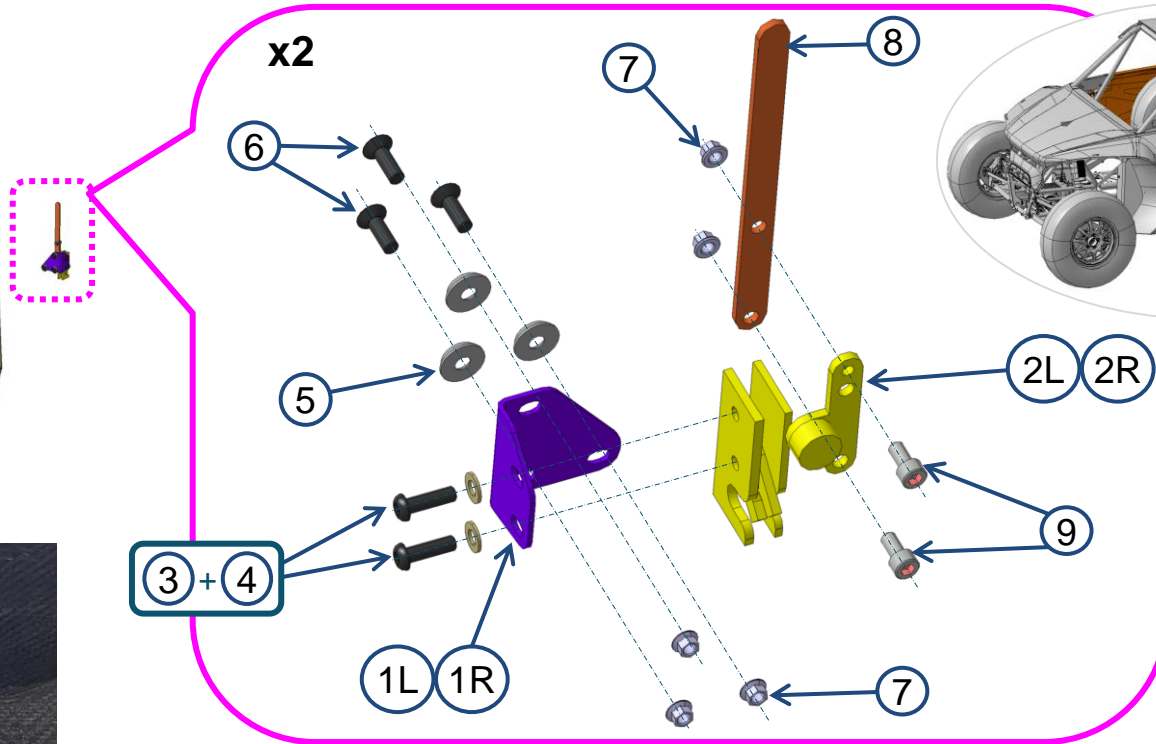
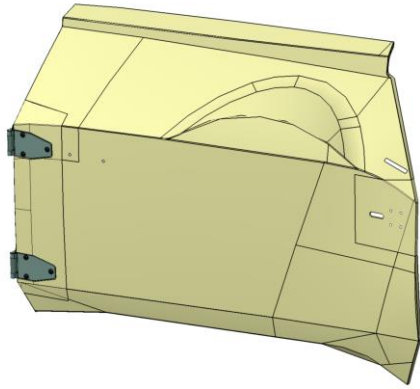

No.	Ref.	Name	Qty.
1L	4015177	DRP-COMPONENT LEFT LATCH HOLDER	1
1R	4015178	DRP-COMPONENT RIGHT LATCH HOLDER	1
2L	4015007	COP LEFT LATCH	1
2R	4015008	COP RIGHT LATCH	1
3	4009150	SUP-PLAIN WASHER	4
4	4008193	SUP - BUTTON HEAD SCREW	4
5	4013844	COP-WASHER COUNTERSUNK ALU M6	6
6	4013841	COP-SCREW TFHC	6
7	4013685	SUP-LOCKNUT WITH FLANGE - M6X1.00 – SIMMONDS	10
8	4015270	DRP-COMPONENT LATCH HANDLE	1
9	4000932	SUP-HEXAGONAL SOCKET CAP SCREW	4



# 14.11 BODY – Hood **without** windshield

**⚠ Before installing, do not forget to glue the foam on the chassis**

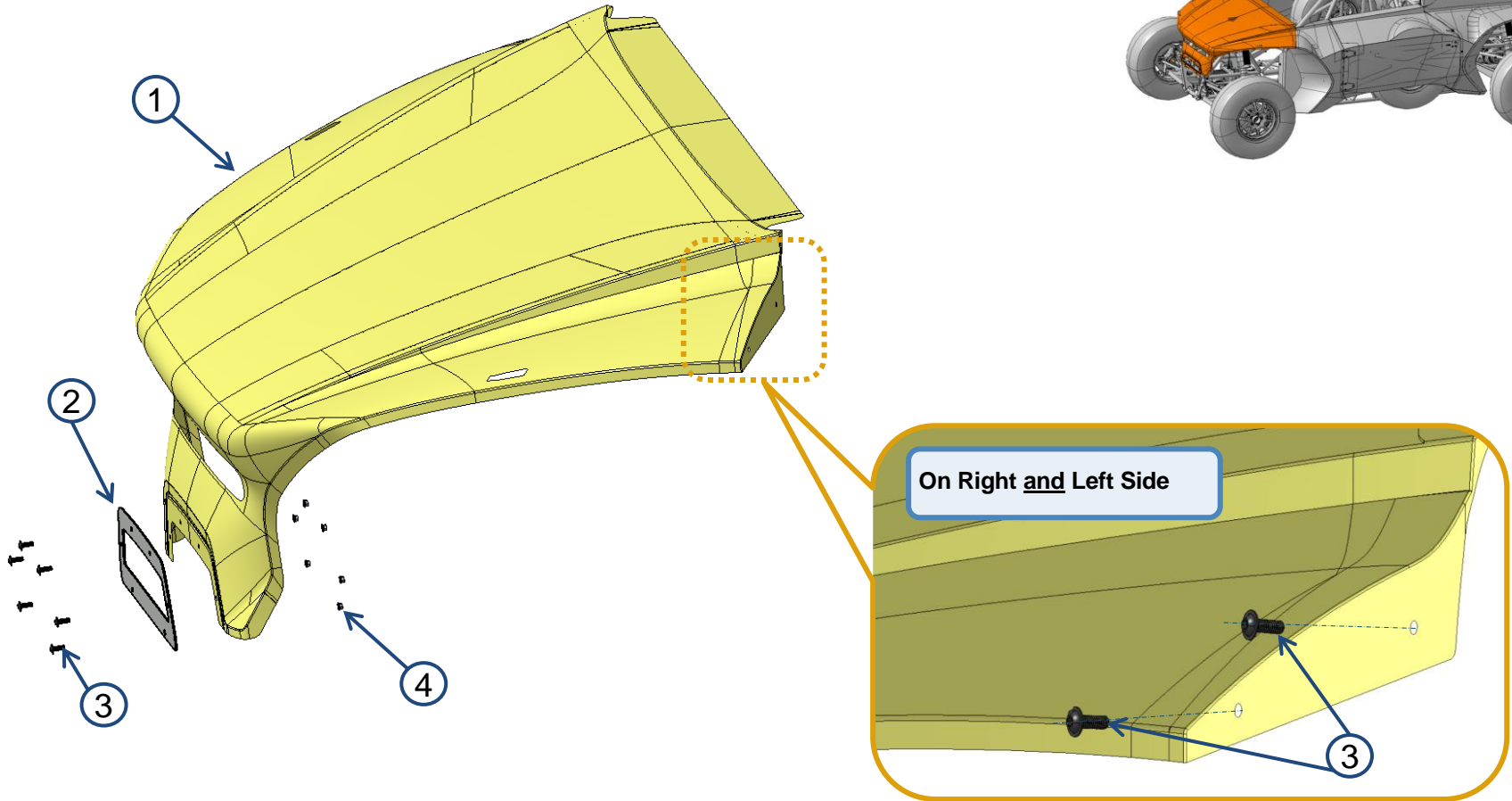
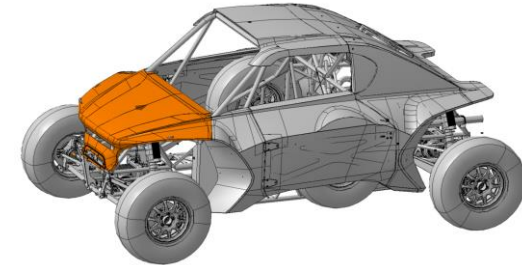

No.	Ref.	Name	Qty.
1	4014223	DRP-COMPONENT CAR HOOD	1
2	4016509	DRP-COMPONENT CARBON FRONT GRILL TH 1.9	1
3	4013534	COP-SCREW BUTTON HEAD WITH FLANGE - M6X16 P100 - CL10.9 – BLACK	10
4	4013685	SUP-LOCKNUT WITH FLANGE - M6X1.00 - SIMMONDS	6

# 14.12 BODY – Awning bay and hood compatible **with** windshield

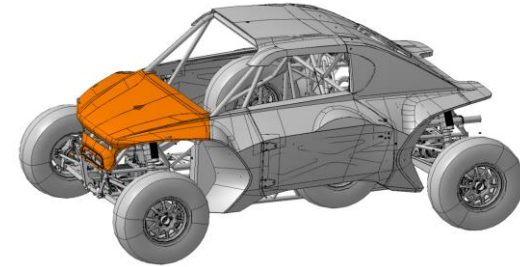

**⚠ Before installing, do not forget to glue the foam on the chassis**

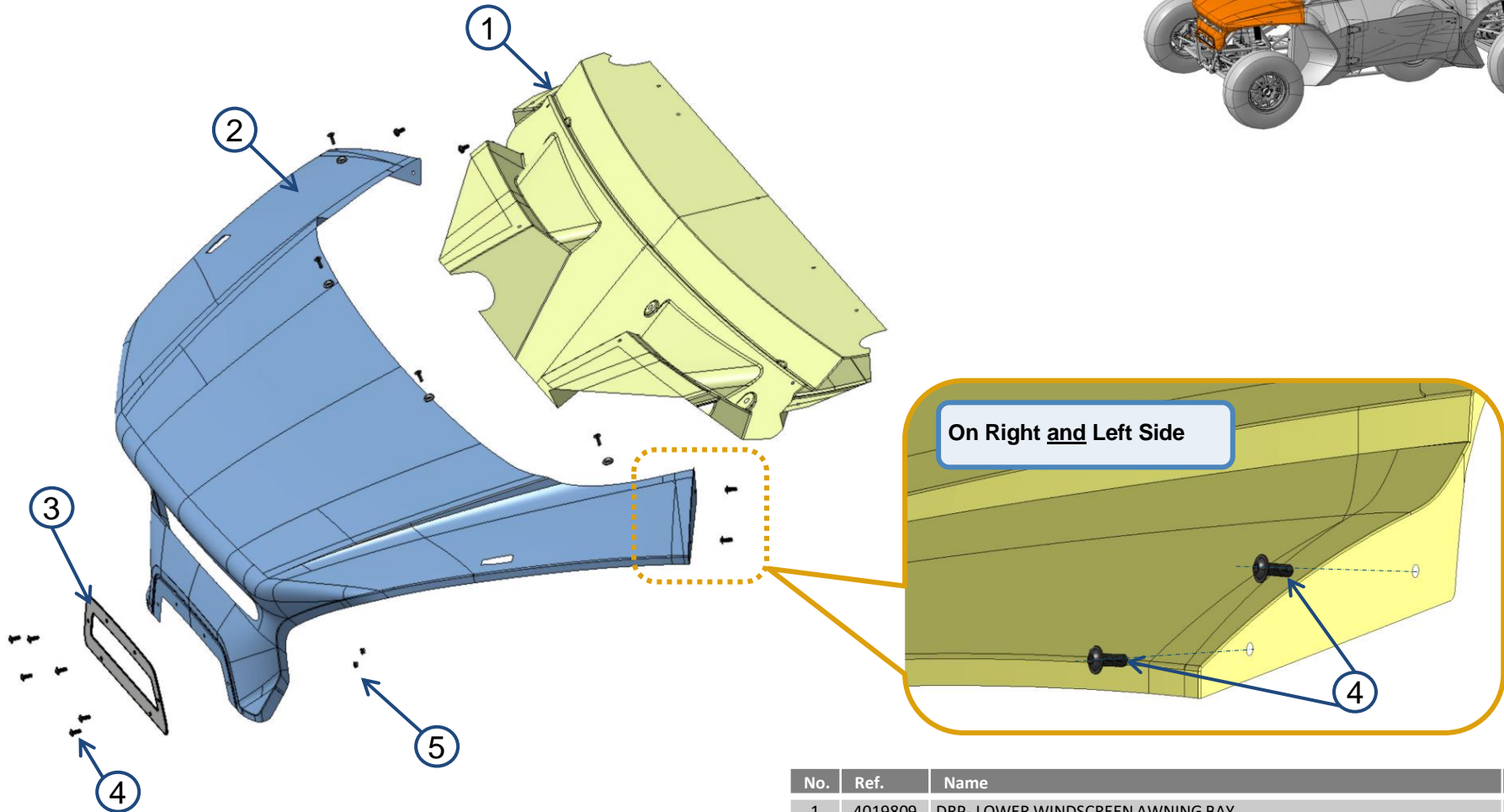

No.	Ref.	Name	Qty.
1	4019809	DRP- LOWER WINDSCREEN AWNING BAY	1
2	4019807	DRP-COMPONENT CAR HOOD COMPATIBLE WINDSCREEN	1
3	4016509	DRP-COMPONENT CARBON FRONT GRILL TH 1.9	1
4	4013534	COP-SCREW BUTTON HEAD WITH FLANGE - M6X16 P100 - CL10.9 – BLACK	14
5	4013685	SUP-LOCKNUT WITH FLANGE - M6X1.00 - SIMMONDS	6

# 14.12.1 BODY – Hood – Wipers motor install

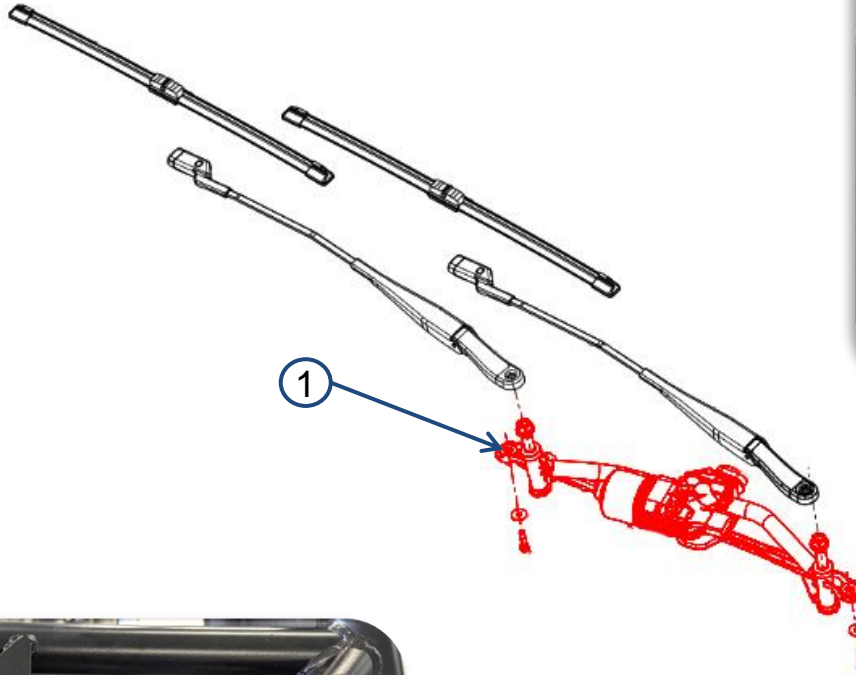

No.	Ref.	Name	Qty.
1	4019816	SUP-WIPER MOTOR	1

# 14.12.2 BODY – Wipers – Washer tank



**4 Bolts + 4 M6 Locknuts + 4 washers**

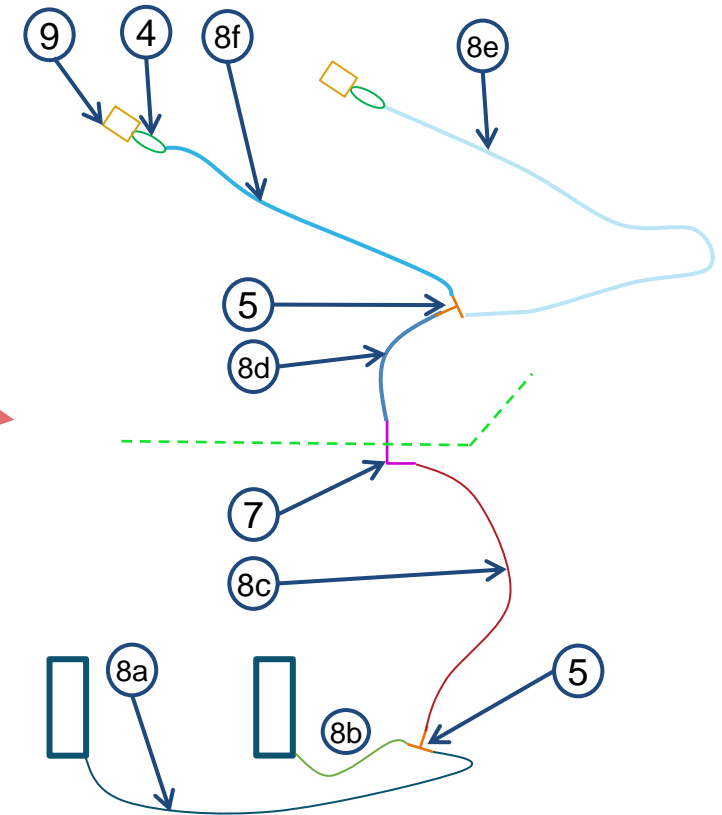

No.	Ref.	Name	Qty.
1	4019193	COP-TANK 5.3L WINDSHIELD WASHER SYSTEM	1
2	4013534	COP-SCREW BUTTON HEAD WITH FLANGE - M6X16 P100 - CL10.9 – BLACK	4
3	4013685	SUP-LOCKNUT WITH FLANGE - M6X1.00 – SIMMONDS	4
4	4020021	COP-CHECK VALVE	2
5	4020022	COP-CONNECTOR TEE Ø4	2
6	4020023	COP-GROMMET Ø6	
7	4020028	COP-CONNECTOR BULKHEAD 90°	1
8	4020024	COP-HOSE TRANSLUCENT Ø4-Ø6-5M	
9	4020029	COP-ARM NOZZLE 9X4 - 2 OVERHEAD JETS	2
10			

# 14.13 BODY – Wipers

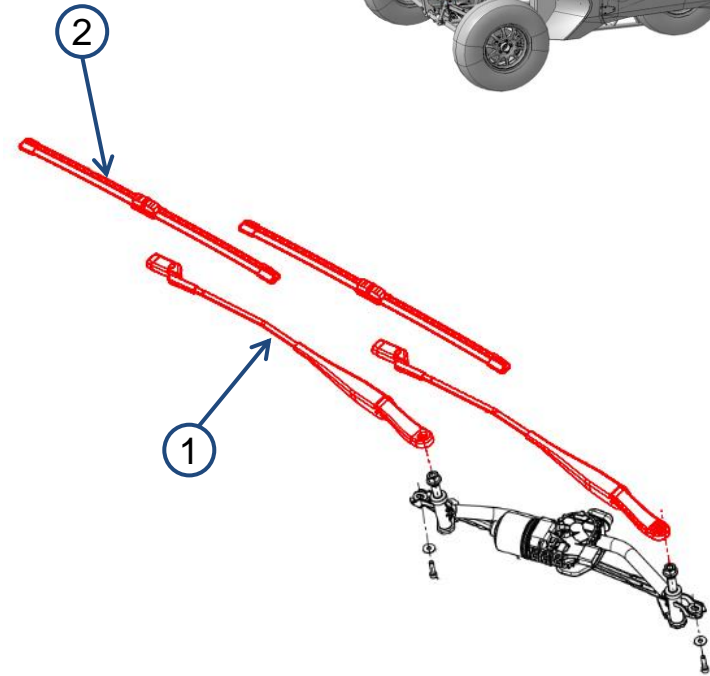
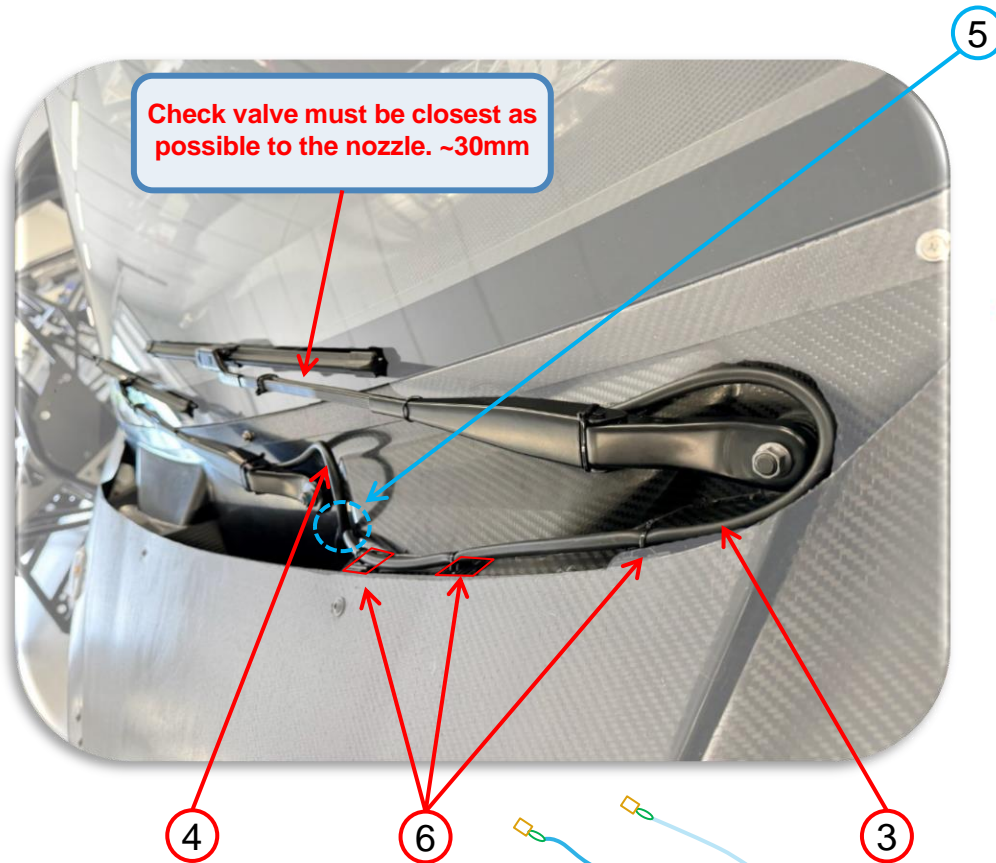
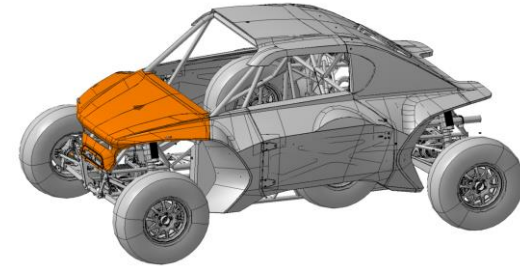

**P.301 – washer circuit**

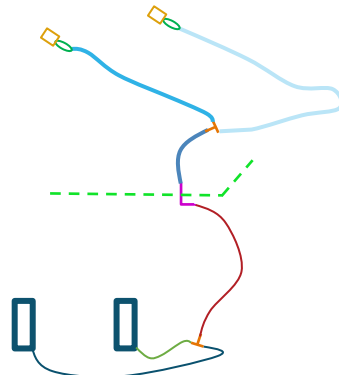

No.	Ref.	Name	Qty.
1	4019817	SUP-WIPER ARM	2
2	4019818	COP-WIPER BLADE	2
3		TUYAU T2 / BUSE BALAI GAUCHE	1
4		TUYAU T2 / BUSE BALAI DROIT	1
5	4020022	COP-CONNECTOR TEE Ø4	1
6	4013292	COP-BASE FLEXIBLE & SELF-ADHESIVE - RISLAN	3
7	4020029	COP-ARM NOZZLE 9X4 - 2 OVERHEAD JETS	2

## 14.14.1 BODY – Roof with Windshield – Windshield installation

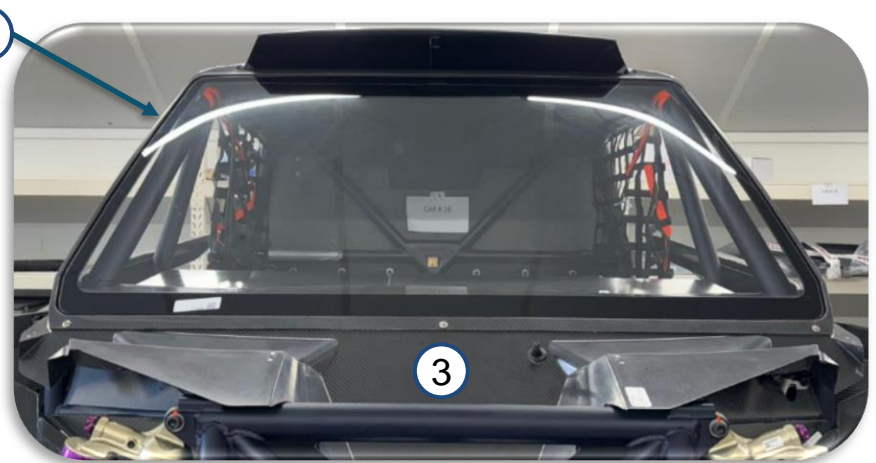
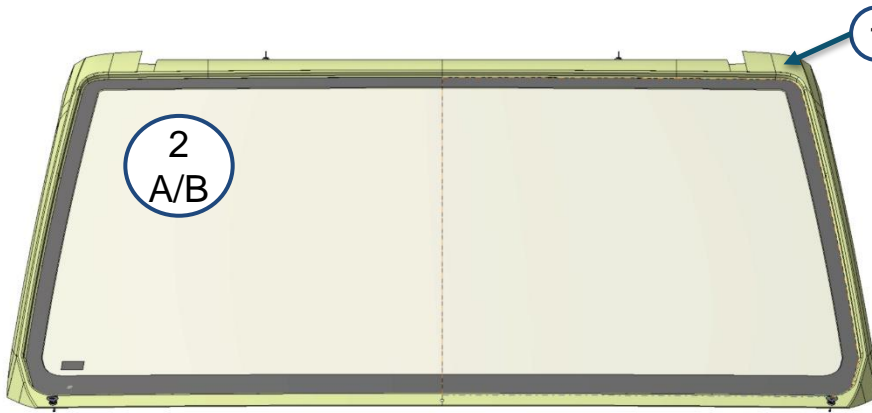

### ■ The windshield is fitted with velcro:

- ▶ Horizontally: 8 pieces with a section: 25mm x 50mm
- ▶ Vertically: 6 pieces with section 12mm x 50 mm
- ▶ Helitape on the roof

No.	Ref.	Name	Qty.
1	4019811	DRP- WINDSCREEN FRAME	1
2A	4019812	DRP- WINDSCREEN	1
2B	4019824	DRP- HEATED WINDSCREEN	1
3	4019809	DRP- LOWER WINDSCREEN AWNING BAY	1

## 14.14.2 BODY – Roof with Windshield – Side panel

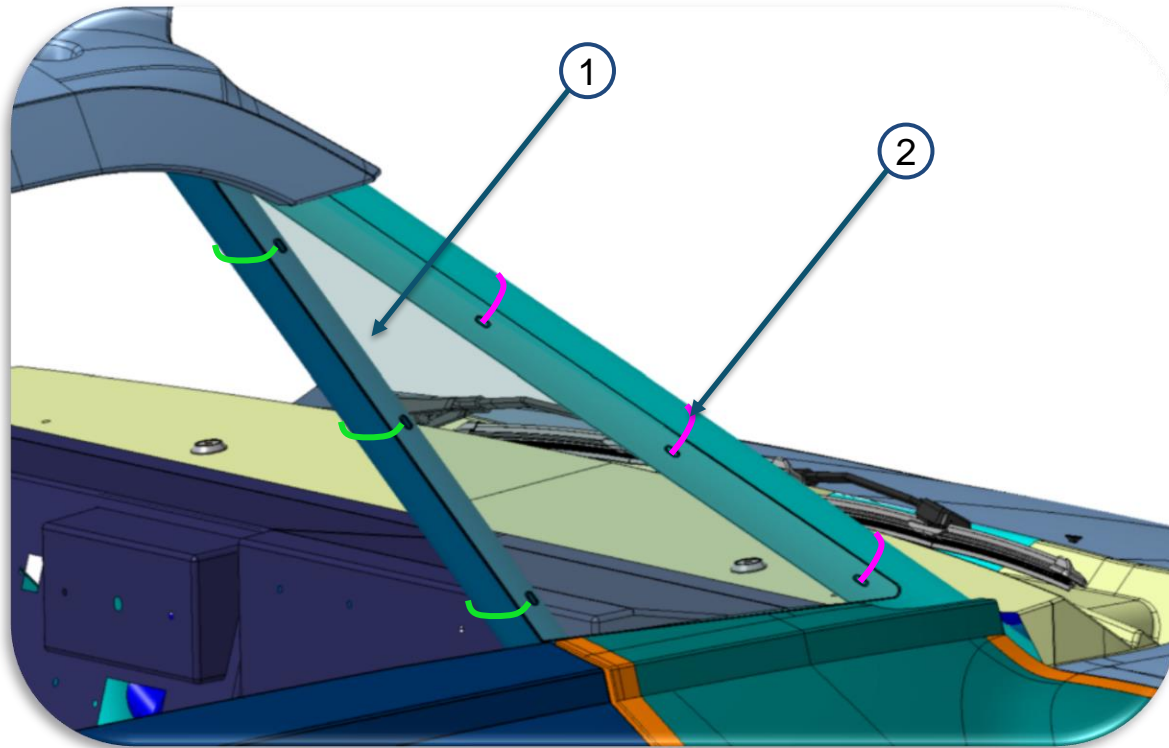

No.	Ref.	Name	Qty.
1	4020446	DRP-COMPONENT FRONT QUARTER PANEL	2
2		Zip-tie 6,5mm	14

# 14.15 BODY – Spare wheel holder Right & Left

Use the centering part adapted to the rims you are using.

KMC / Braid White

KMC Light / Braid Anthracite

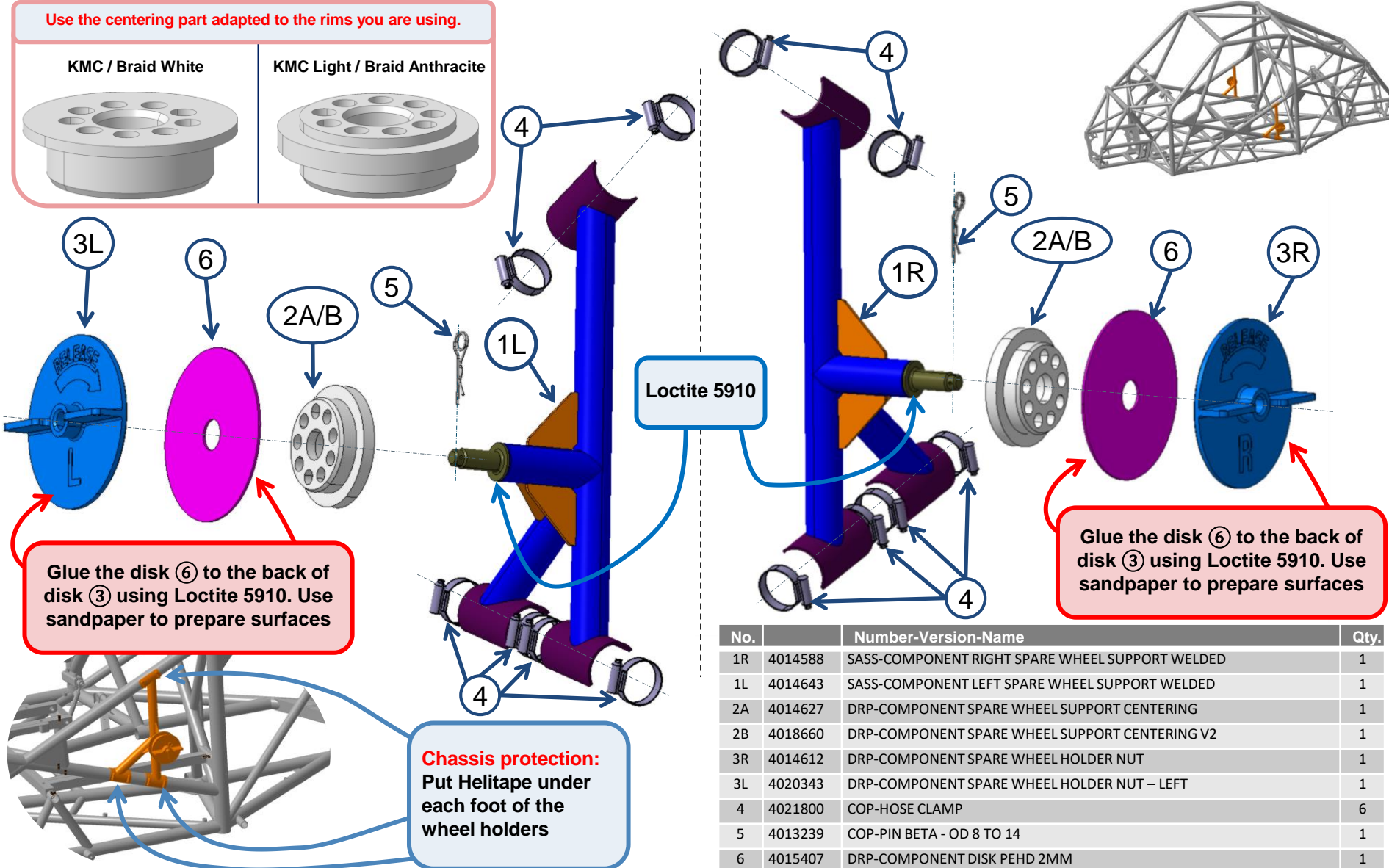
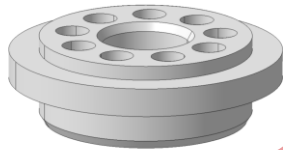
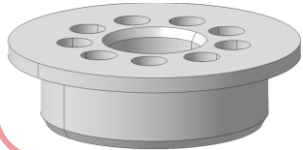

Glue the disk ⑥ to the back of disk ③ using Loctite 5910. Use sandpaper to prepare surfaces

Glue the disk ⑥ to the back of disk ③ using Loctite 5910. Use sandpaper to prepare surfaces

**Chassis protection:**  
Put Helitape under each foot of the wheel holders

No.		Number-Version-Name	Qty.
1R	4014588	SASS-COMPONENT RIGHT SPARE WHEEL SUPPORT WELDED	1
1L	4014643	SASS-COMPONENT LEFT SPARE WHEEL SUPPORT WELDED	1
2A	4014627	DRP-COMPONENT SPARE WHEEL SUPPORT CENTERING	1
2B	4018660	DRP-COMPONENT SPARE WHEEL SUPPORT CENTERING V2	1
3R	4014612	DRP-COMPONENT SPARE WHEEL HOLDER NUT	1
3L	4020343	DRP-COMPONENT SPARE WHEEL HOLDER NUT – LEFT	1
4	4021800	COP-HOSE CLAMP	6
5	4013239	COP-PIN BETA - OD 8 TO 14	1
6	4015407	DRP-COMPONENT DISK PEHD 2MM	1



## Section 15

### EXTERIOR TRIM

# 15.1 EXTERIOR TRIM – Ski – Overview

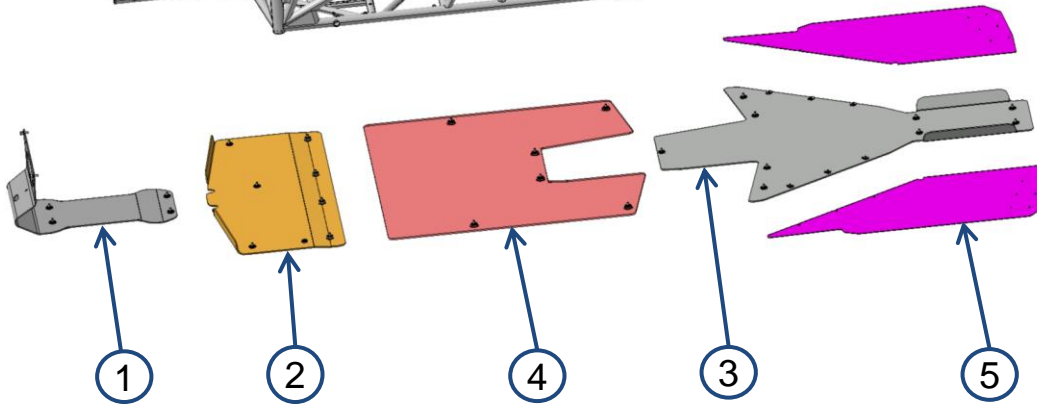
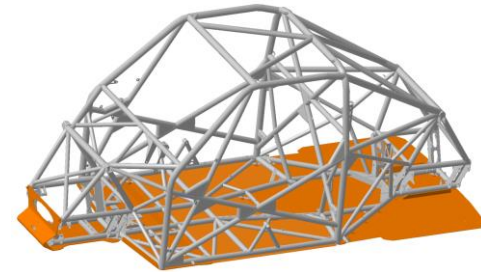
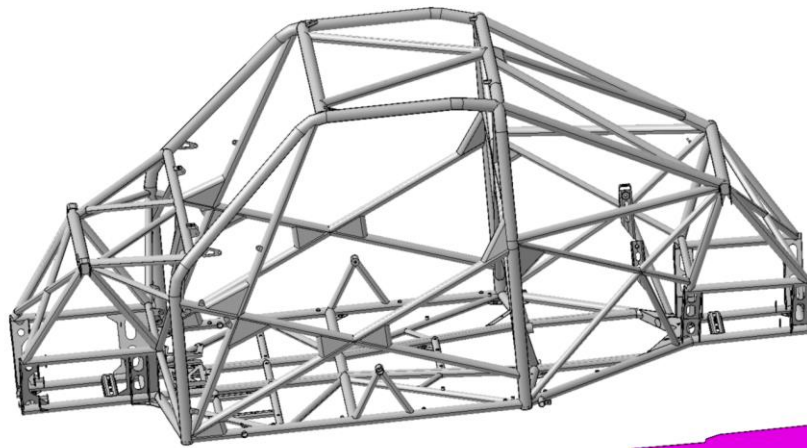

**Assembly Order :**

- 1) FUEL TANK SKI GUARD
- 2) CENTRAL FRONT SKI
- 3) FRONT SKI
- 4) REAR SOFT FLAP
- 5) REAR SKI EQUIPPED

No.	Ref.	Name	Qty.
1	4012759	SASS-FRONT SKI – EQUIPPED	1
2	4012762	SASS-CENTRAL FRONT SKI – EQUIPPED	1
3	4012764	SASS-REAR SKI – EQUIPPED	1
4	4014418	SASS-FUEL TANK SKI GUARD	1
5	4012766	SASS-REAR SOFT FLAP - EQUIPPED	2

# 15.2 EXTERIOR TRIM – Ski – Front Ski



Assembly tips .???

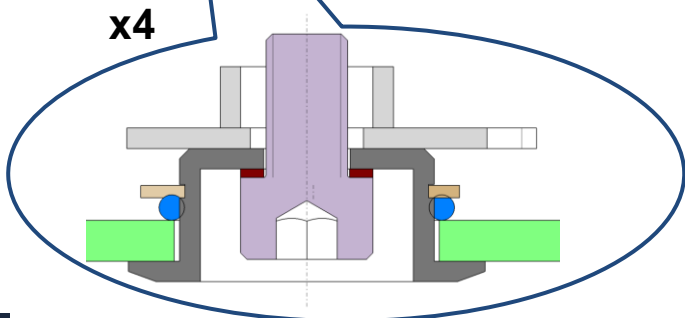
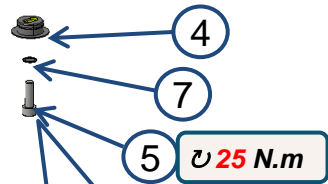
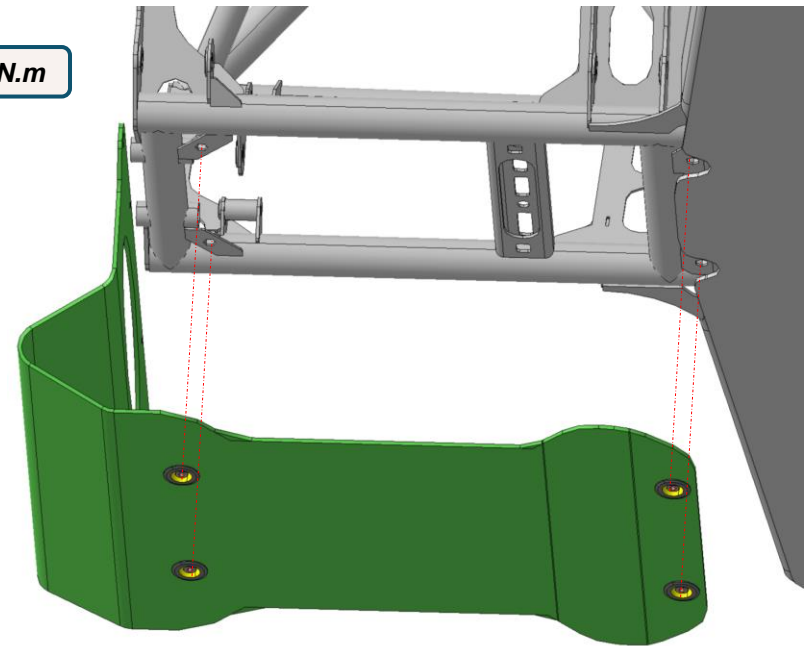
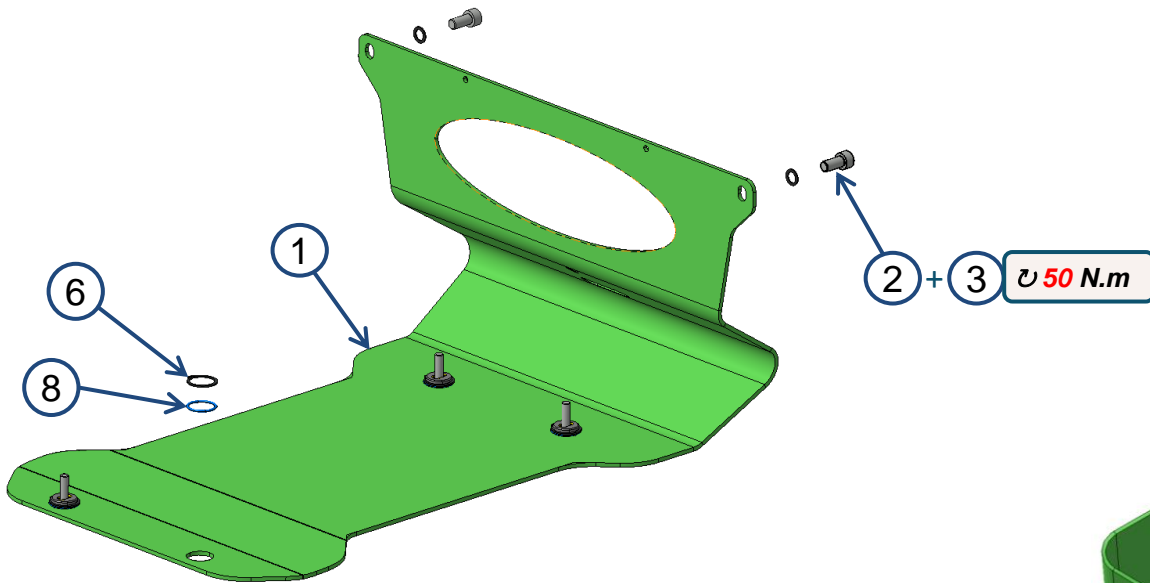

No.	Ref.	Name	Qty.
1	4012761	DRP-FRONT SKI - MAIN BODY	1
2	4000641	SUP-HEXAGONAL SOCKET CAP SCREW ISO 4762 M10X22-22 P150 CL10.9 A B	2
3	4013576	COP-WASHER Ø10 SCHNORR	2
4	4012774	DRP-BUSHING SKI – NORMAL	4
5	4000965	SUP-HEXAGONAL SOCKET CAP SCREW ISO 4762 M8X25-25 P125 CL12.9 A B	4
6	4012832	SUP-EXTERNAL CIRCLIPS D25X1.2 - DIN 471 A	4
7	4013575	COP-WASHER Ø8 SCHNORR	4
8	4016523	SUP-O-RING	4

# 15.3 EXTERIOR TRIM – Ski – Fuel Tank Ski

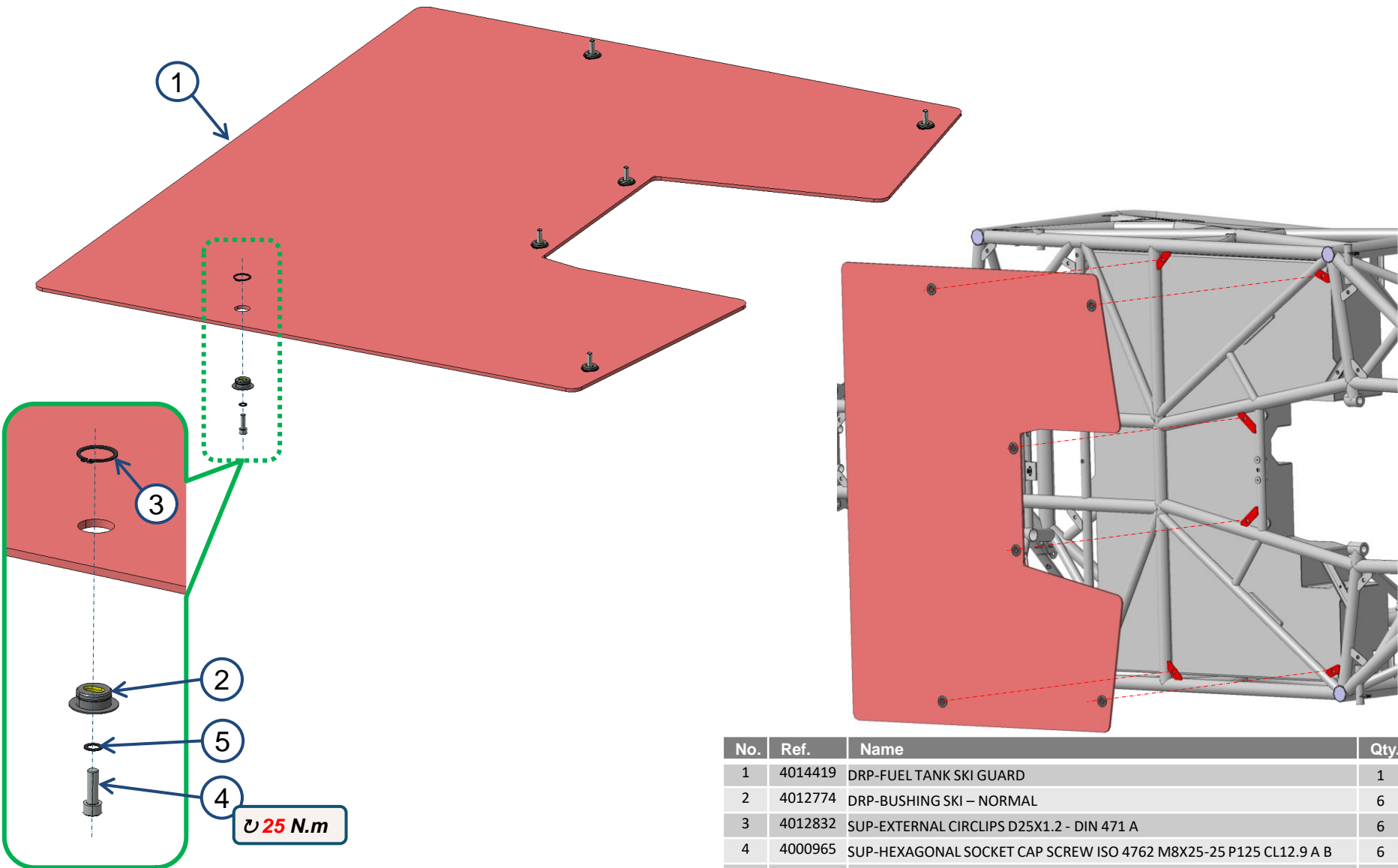

No.	Ref.	Name	Qty.
1	4014419	DRP-FUEL TANK SKI GUARD	1
2	4012774	DRP-BUSHING SKI – NORMAL	6
3	4012832	SUP-EXTERNAL CIRCLIPS D25X1.2 - DIN 471 A	6
4	4000965	SUP-HEXAGONAL SOCKET CAP SCREW ISO 4762 M8X25-25 P125 CL12.9 A B	6
5	4013575	COP-WASHER Ø8 SCHNORR	6

# 15.4 EXTERIOR TRIM – Ski – Central Front Ski

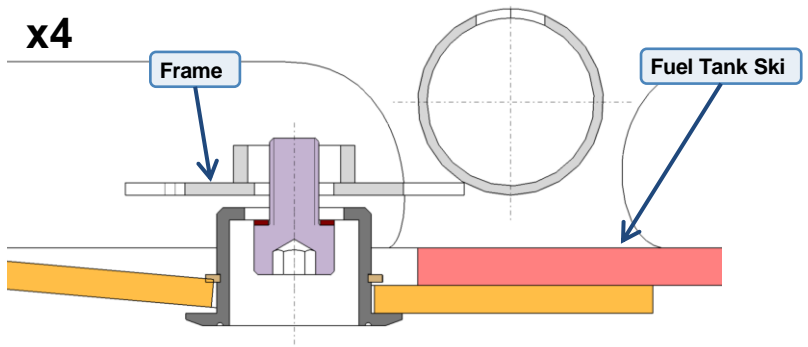
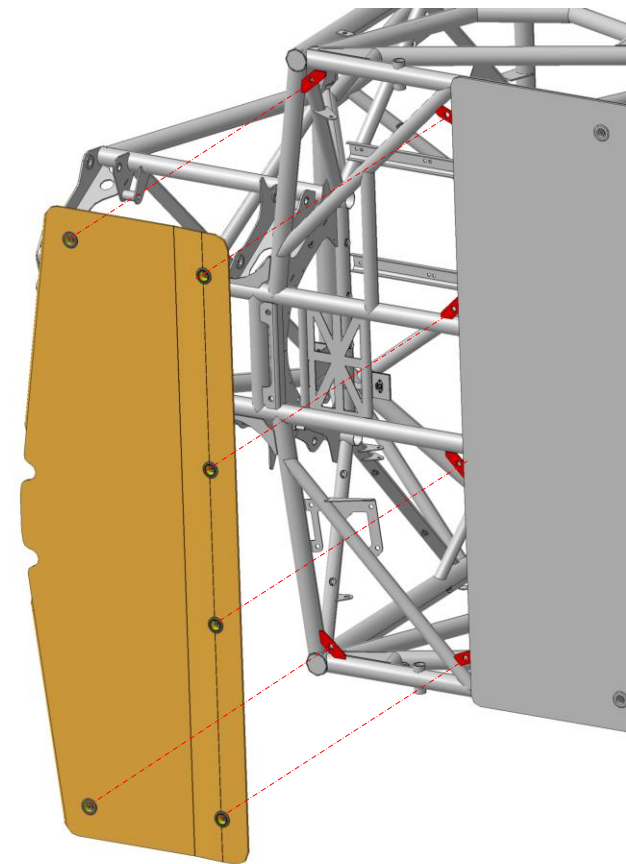
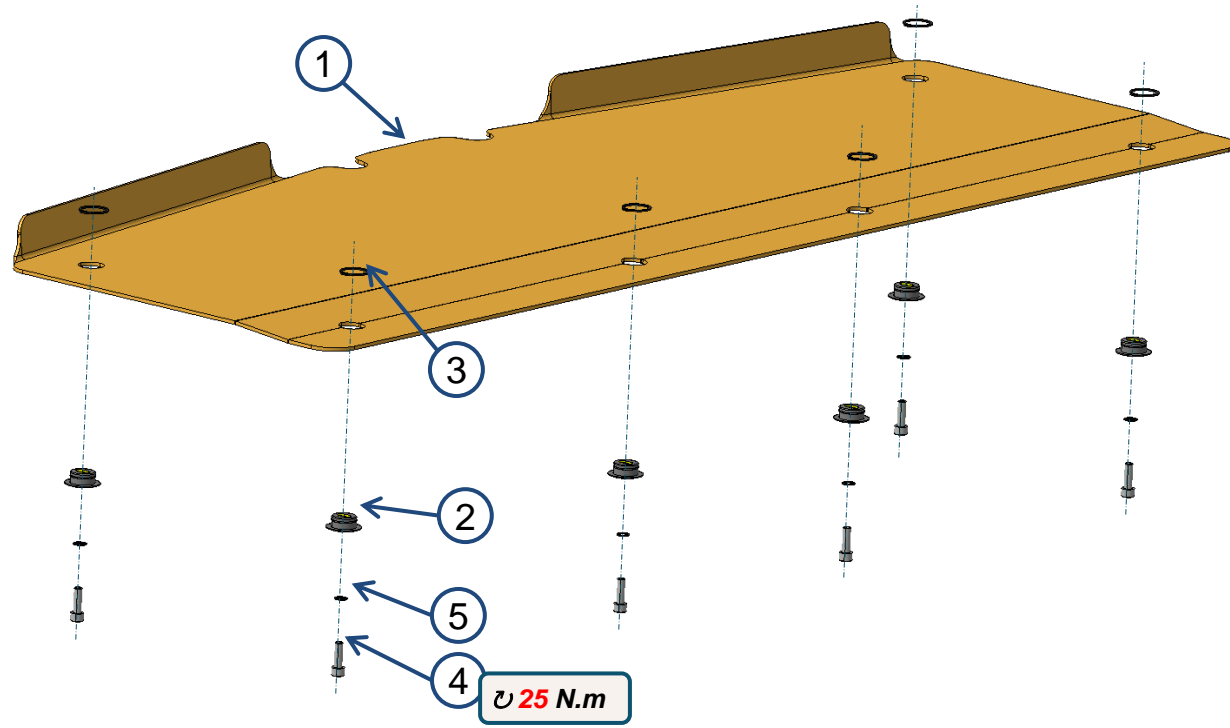

**Assembly tips .???**

No.	Ref.	Name	Qty.
1	4012763	DRP-CENTRAL SKI	1
2	4012774	DRP-BUSHING SKI – NORMAL	6
3	4012832	SUP-EXTERNAL CIRCLIPS D25X1.2 - DIN 471 A	6
4	4000965	SUP-HEXAGONAL SOCKET CAP SCREW ISO 4762 M8X25-25 P125 CL12.9 A B	6
5	4013575	COP-WASHER Ø8 SCHNORR	6

# 15.5 EXTERIOR TRIM – Ski – Rear Ski

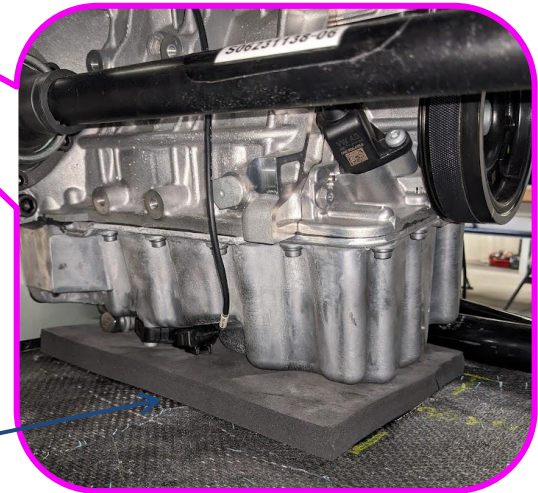
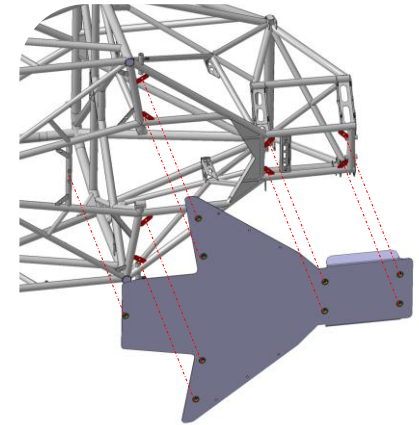
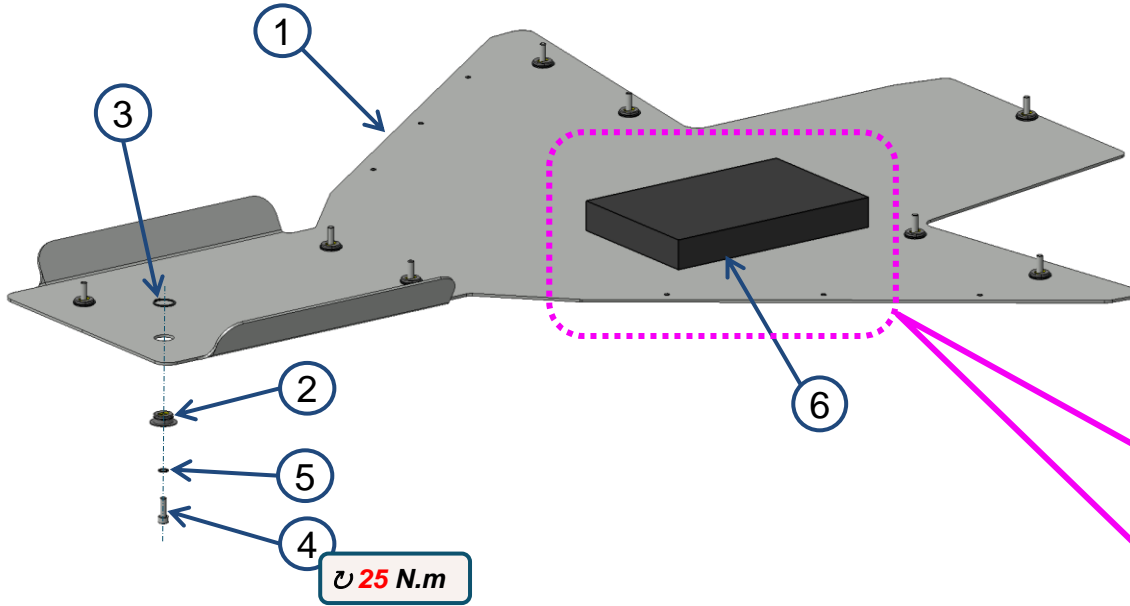

**Foam slab must be positioned between the ski and the oil pan**

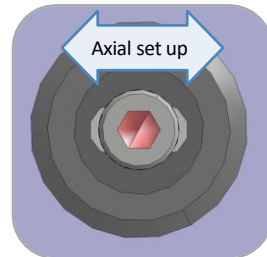
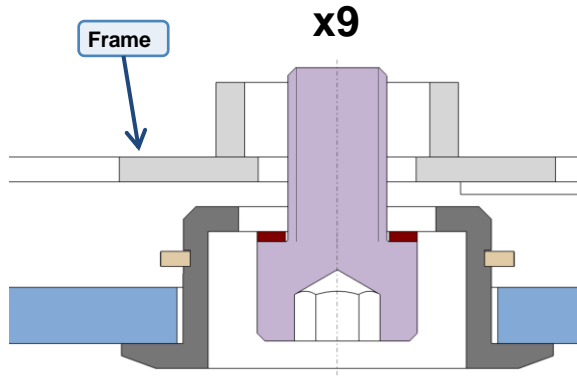

No.	Ref.	Name	Qty.
1	4012765	DRP-REAR SKI	1
2	4012774	DRP-BUSHING SKI – NORMAL	9
3	4012832	SUP-EXTERNAL CIRCLIPS D25X1.2 - DIN 471 A	9
4	4000965	SUP-HEXAGONAL SOCKET CAP SCREW ISO 4762 M8X25-25 P125 CL12.9 A B	9
5	4013575	COP-WASHER Ø8 SCHNORR	9
6	4018349	DRP-FOAM REAR SKI MOTOR - EPDM TH. 40MM - 200x300MM	1

# 15.6 EXTERIOR TRIM – Ski – Rear Soft Flap

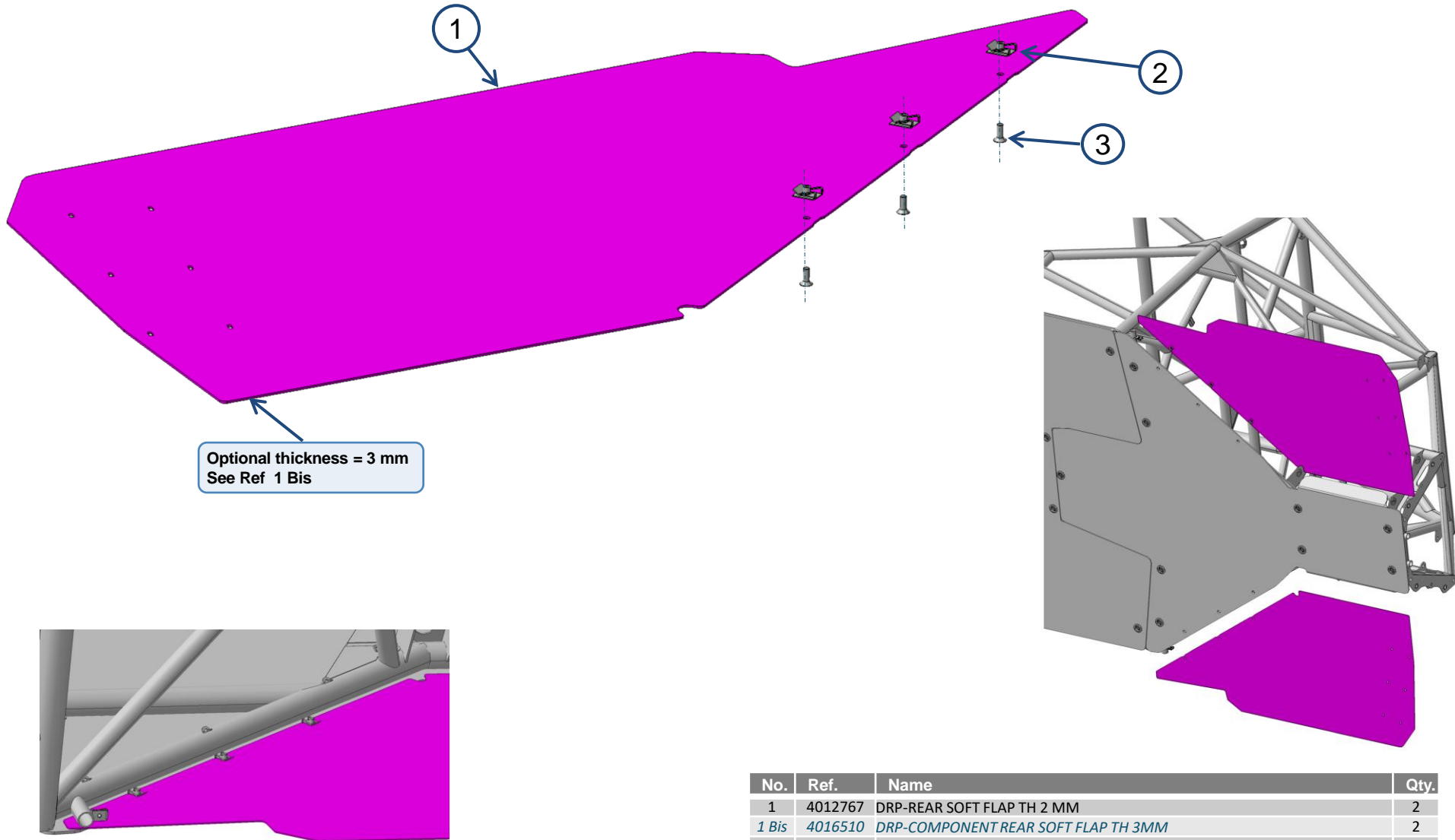

No.	Ref.	Name	Qty.
1	4012767	DRP-REAR SOFT FLAP TH 2 MM	2
1 Bis	4016510	DRP-COMPONENT REAR SOFT FLAP TH 3MM	2
2	4013533	COP-NUT PINCH M6	6
3	4003390	SUP-HEXAGON SOCKET COUNTERSUNK HEAD CAP SCREW M6X16-12.5 P100 CL10.9 ISO10642 A B	6

# 15.7 EXTERIOR TRIM – Rear View Mirrors

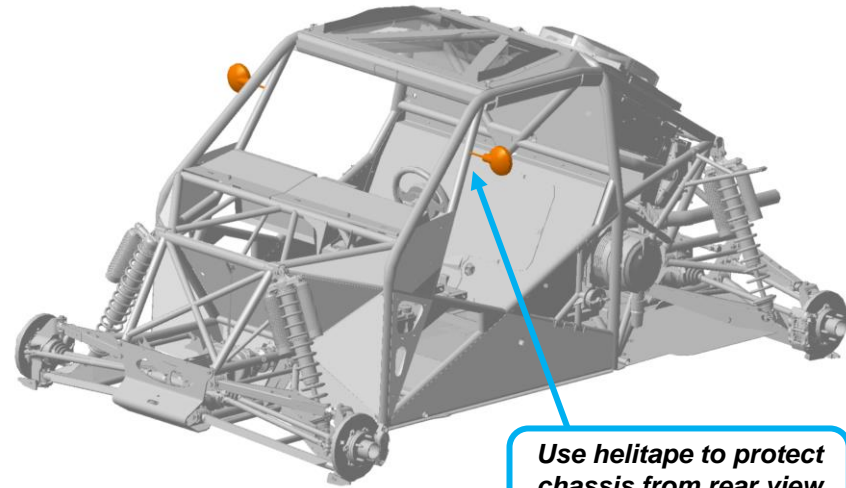
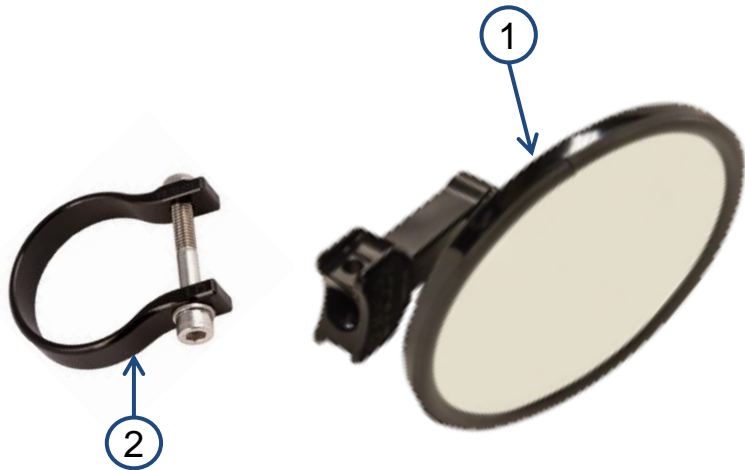

*Use helitape to protect chassis from rear view mirrors clamps x2 layers*

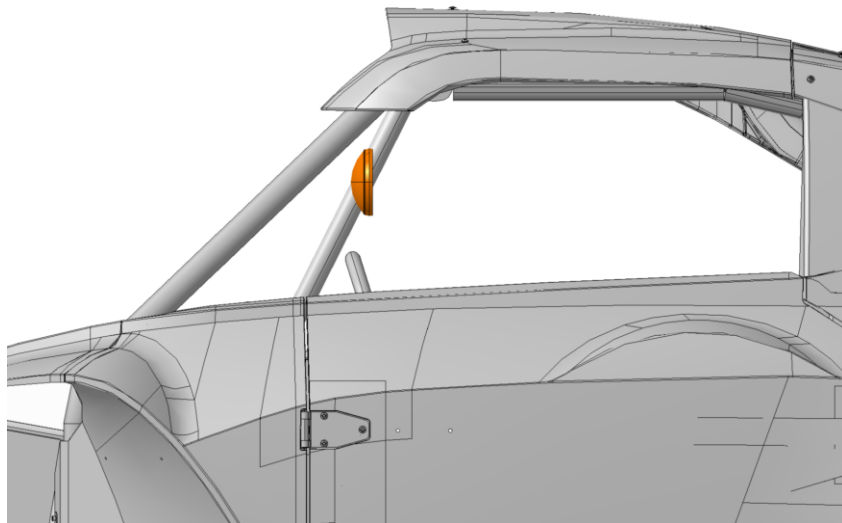

No.	Ref.	Name	Qty.
1	4016461	COP-5 INCH ROUND CONVEX SIDE MIRROR BLACK	2
2	4018034	COP-1.625 INCH ROLLBAR STRAP CLAMP BLACK	2



## Section 16

# ACCESSORIES

# 16.1 ACCESSORIES – Drinking Water

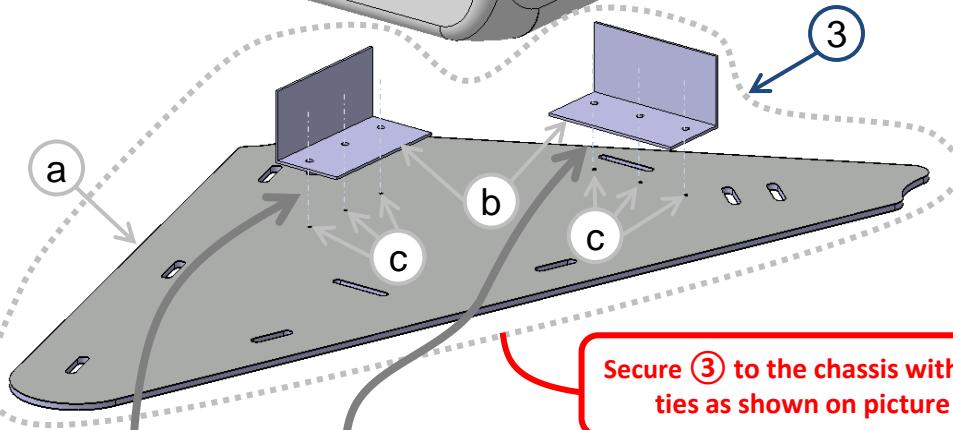
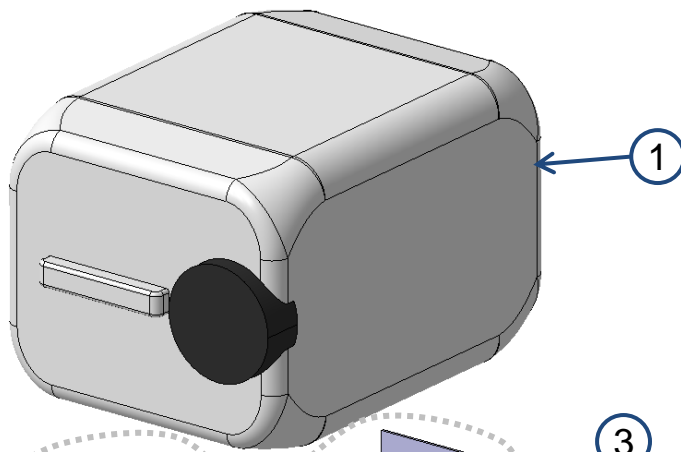

Secure ③ to the chassis with zip ties as shown on picture

The corners ② should be glued and riveted ③ to the carbon plate ①

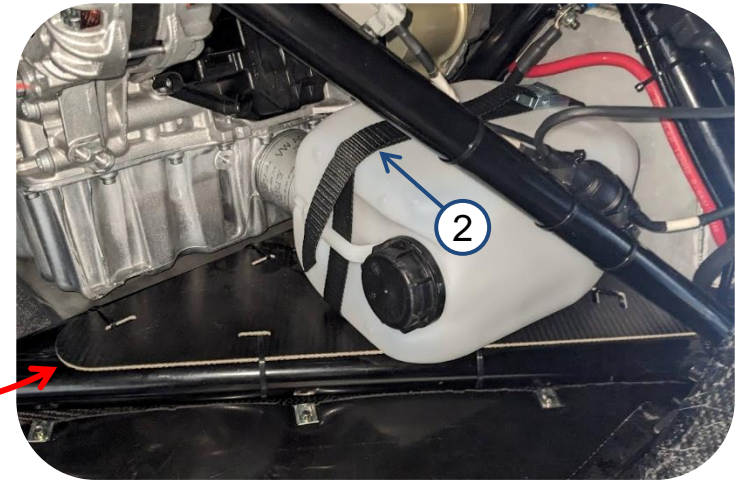

No.	Ref.	Name.	Qty.
1	4014796	COP-TO BE DEFINED WATER TANK 5L - PEHD	1
2	4016637	COP-TO BE DEFINED LASHING STRAP 250KG - 25MM - 1M - BLACK	1
3	4016742	SASS-TO BE DEFINED WATER TANK HOLDER →	1
a	4015155	DRP-COMPONENT WATER TANK HOLDER	1
b	4018390	DRP-COMPONENT ALUMINIUM 40x40x1.5MM CORNER - L80MM	2
c	4013908	COP-TO BE DEFINED RIVETS ALUMINIUM Ø4X10	6

## 16.2 ACCESSORIES – Engine oil and brake fluid

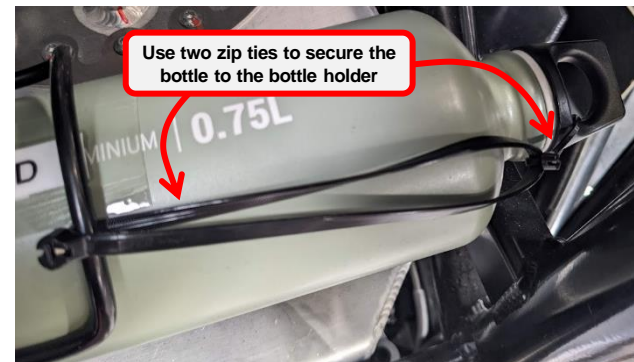
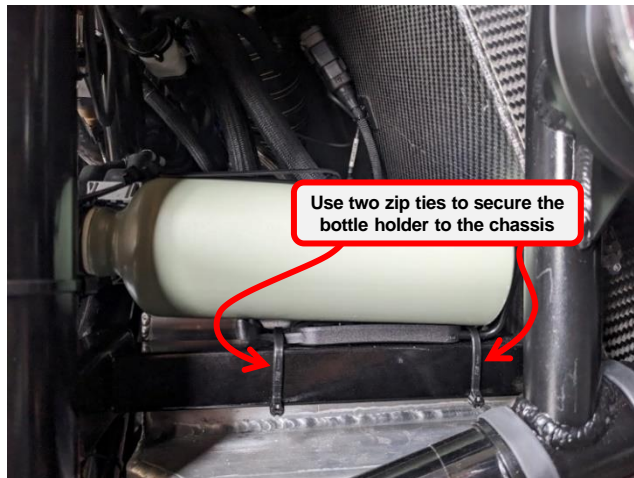
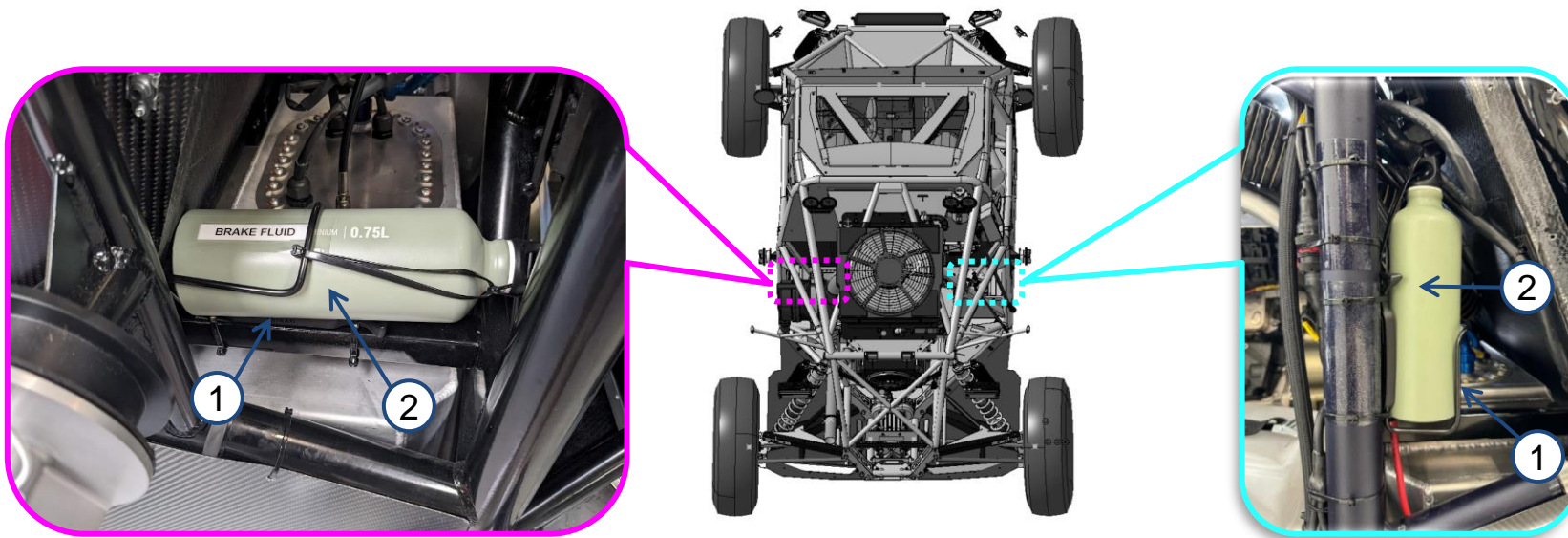

No.	Ref.	Name	Qty.
1	4015292	COP-TO BE DEFINED BOTTLE HOLDER TRIBAN 100 METAL BLACK	2
2	4015242	COP-TO BE DEFINED BOTTLE ALU 0.75L QUECHUA	2

## 16.3 ACCESSORIES – Sand Plate Holder

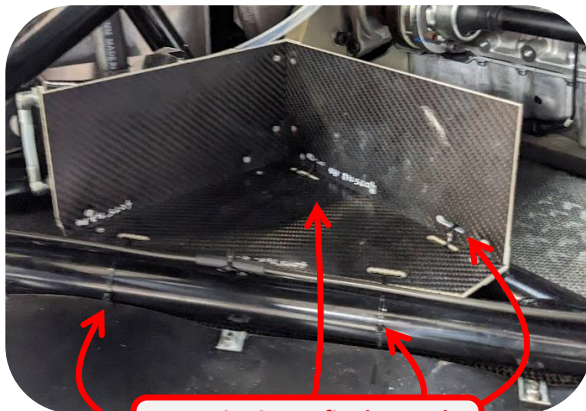
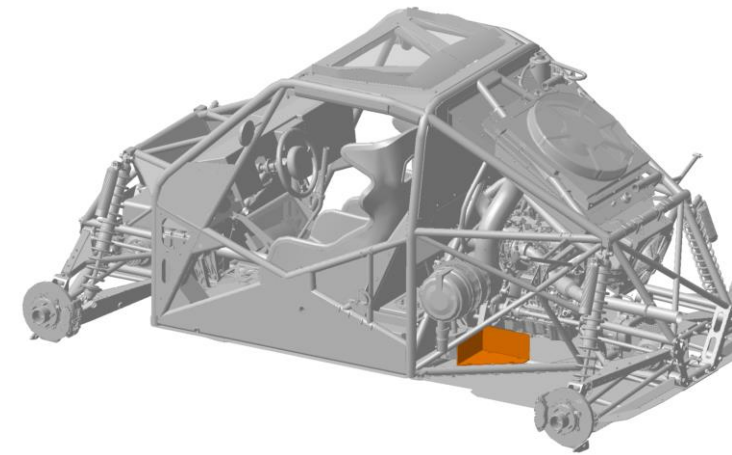
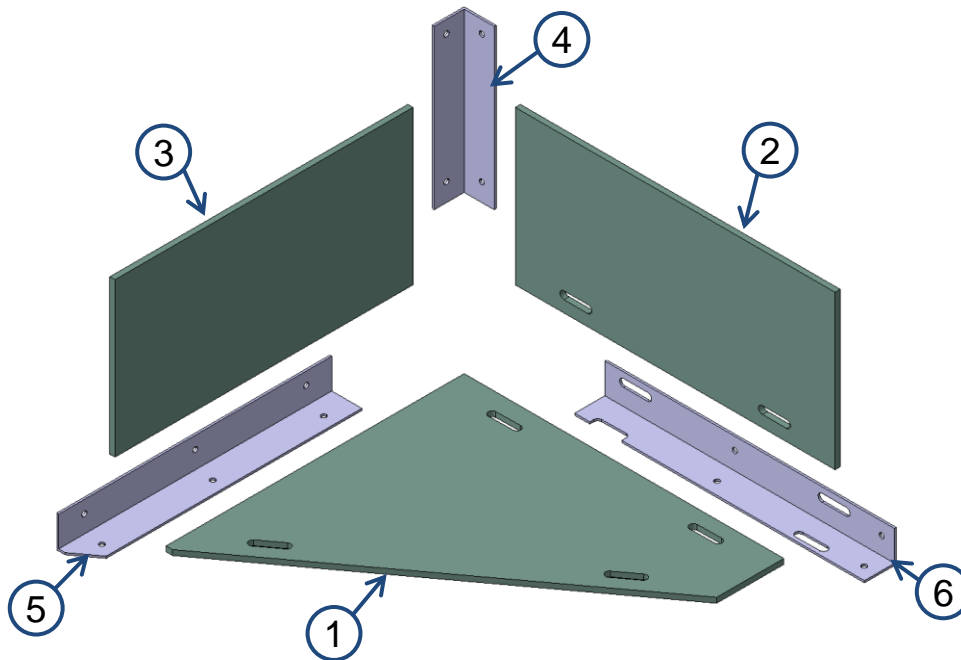

Use zip ties to fix the sand plate holder to the chassis

Drill the carbon plates after positioning the aluminium corners

If the slotted holes are not drilled in (6), use plates (1) and (2) as templates.

Carbon plates and aluminium corners must be glued and riveted together with (7).

No.	Ref.	Name	Qty.
1	4015146	DRP-COMPONENT CALE DESENSABLAGE A	1
2	4015147	DRP-COMPONENT CALE DESENSABLAGE B	1
3	4015148	DRP-COMPONENT CALE DESENSABLAGE C	1
4	4018398	DRP-COMPONENT ALUMINIUM CORNER 25X25X1.5MM - L 124MM	1
5	4018399	DRP-COMPONENT ALUMINIUM CORNER 25X25X1.5MM - L 226.5MM	1
6	4018400	DRP-COMPONENT ALUMINIUM CORNER 25X25X1.5MM - L 212.5MM	1
7	4013908	COP-TO BE DEFINED RIVETS ALUMINIUM Ø4X10	14

# 16.4 ACCESSORIES – Towing

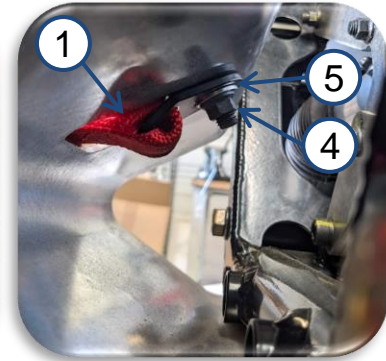
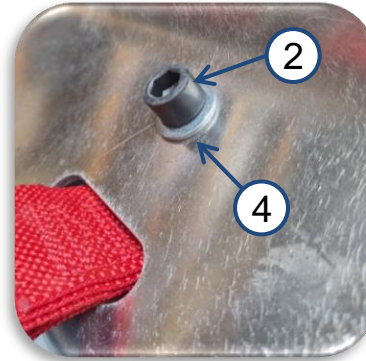
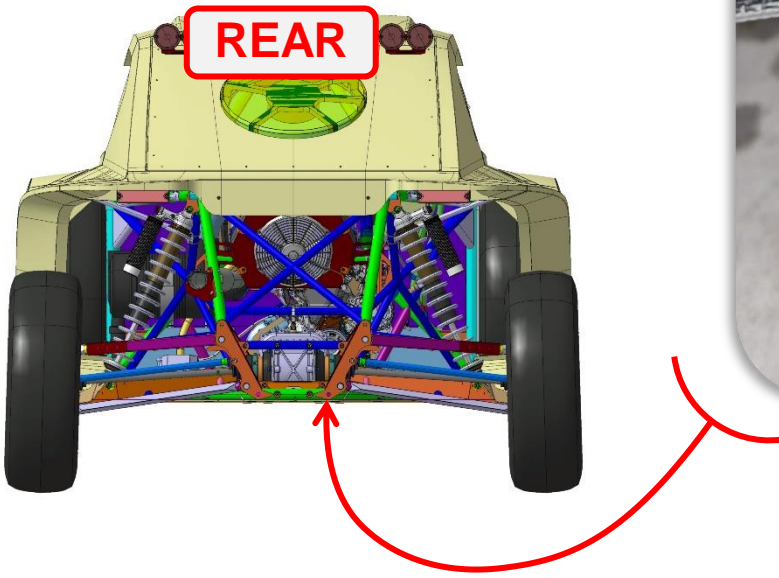
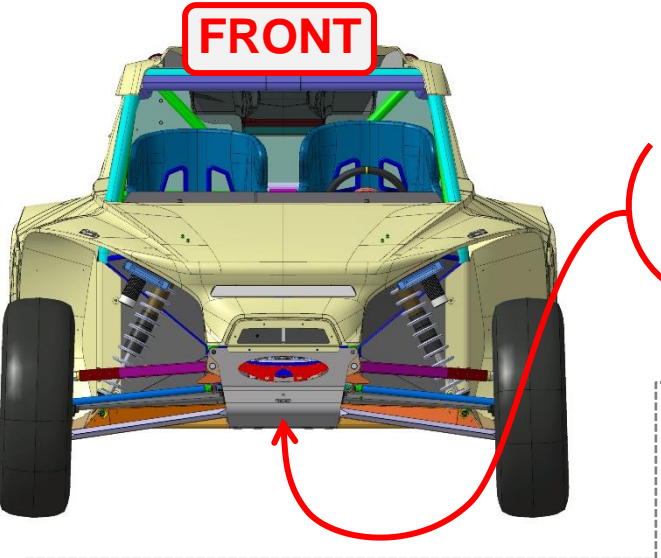

No.	Ref.	Name	Qty.
1	4014824	COP-TOW STRAP – SPARCO	2
2	4000990	SUP - HEXAGONAL SOCKET CAP SCREW ISO 4762 M10X25-25 P150 CL 12.9 A B	1
3	4000992	SUP - HEXAGONAL SOCKET CAP SCREW ISO 4762 M10X35-32 P150 CL 12.9 A B	1
4	4009168	SUP - PLAIN WASHER D10XD22X2 TYPE M NFE25-514 A EZ	3
5	4014980	SUP - LOCKNUT WITH FLANGE - M10X1.50 - SIMMONDS	1

# 16.5 ACCESSORIES – Refuel Hose, Refuel Vent Hose, Fuel Drain Hose



**REFUEL HOSE**



**REFUEL VENT HOSE**

No.	Ref.	Name	Qty.
1	4017395	COP-CONNECTOR FEMALE DASH12 G-SPT12-1658-ECO	1
4	4015025	COP-HOSE CLAMP TORRO_9_ZINGUE_30-45MM	2
5	4013495	COP-HOSE SILICONE ØINT32 BENDED 90° - BLACK	1

**FUEL DRAIN HOSE**

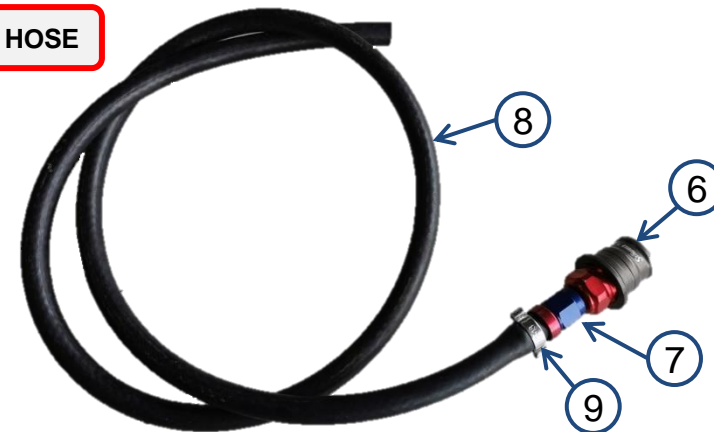

No.	Ref.	Name	Qty.
1	4017395	COP-CONNECTOR FEMALE DASH12 G-SPT12-1658-ECO	1
2	4018134	SUP-FILTER FUNNEL Ø135MM- Ø380MM FOR REFUEL HOSE	1
3	4013496	COP-HOSE SILICONE ØINT32 BENDED 45° - BLACK	1
4	4015025	COP-HOSE CLAMP TORRO_9_ZINGUE_30-45MM	2

No.	Ref.	Name	Qty.
6	4017380	COP-CONNECTOR FEMALE DASH6 SPT 08.1655/L/IV	1
7	4014914	COP-CONNECTOR HOSE DASH6 FEMALE 9/16-18" - STRAIGHT – PUSHFIT	1
8	4018137	DRP-HOSE FUEL DRAIN Ø8MM X 1.2M	1
9	4015252	SUP-HOSE CLAMP COLLIER A 2 OREILLES Ø15-Ø18MM	1

## Section 17

# ELECTRICAL COMPONENTS

# 17.1 ELECTRICAL COMPONENTS – Power Unit Battery 12V – Main Power Circuit

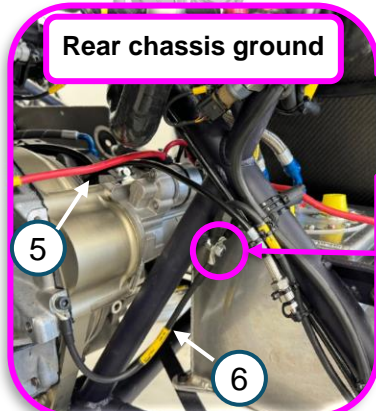
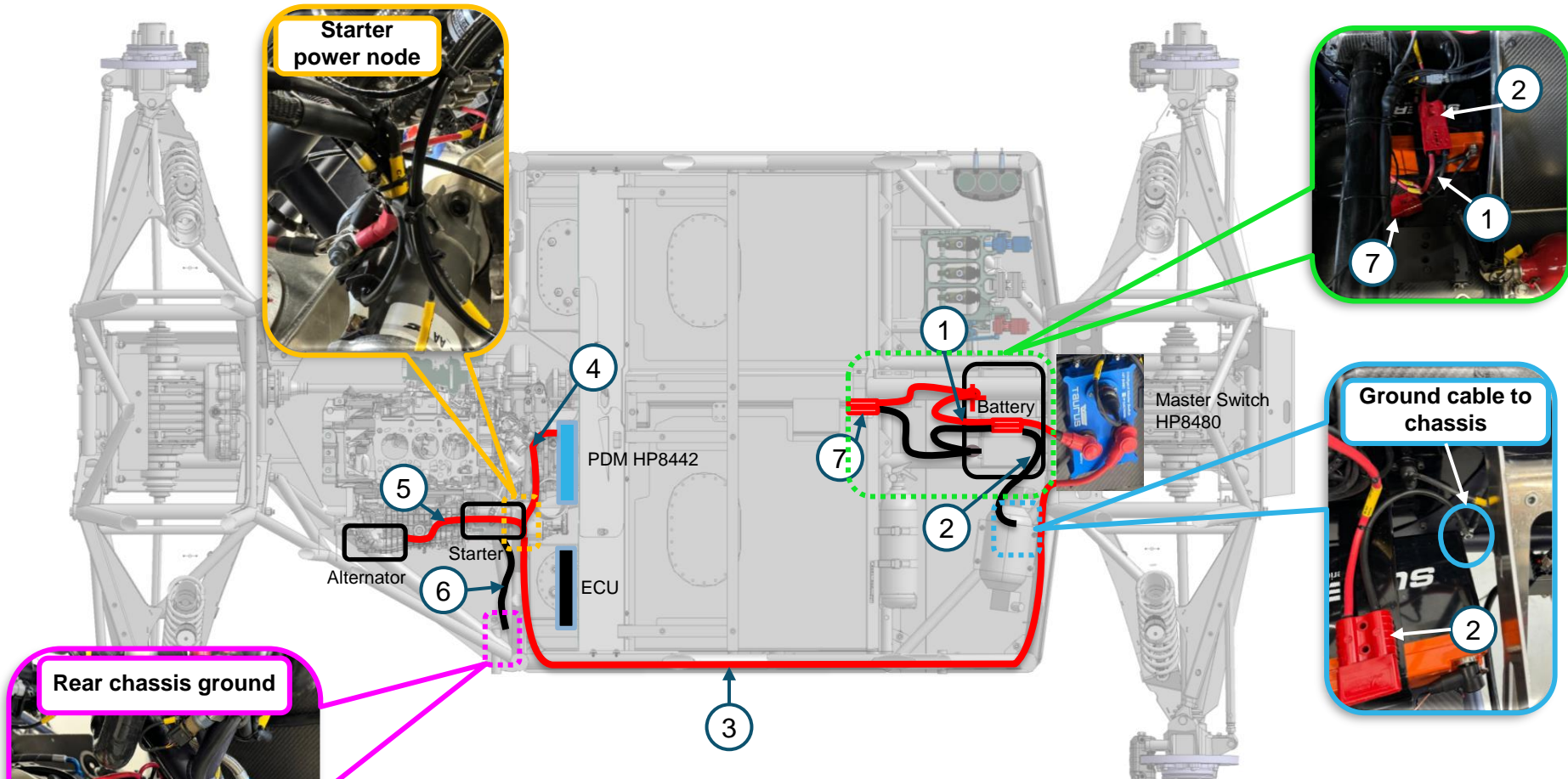

**Engine ground  
ECU Ground  
Rear chassis ground**

No.	Ref.	Name	Qty.
1	4018921	CABLE BATTERY MAIN POWER CONNECTOR	1
2	4018922	CABLE MAIN POWER CONNECTOR TO MASTER SWITCH AND GROUND	1
3	4018923	SASS CABLE MASTER SWITCH – STARTER	1
4	4021397	SASS CABLE HP8442 – STARTER	1
5	4013043	SASS CABLE ALTERNATOR STARTER	1
6	4013039	SASS CABLE ENGINE GROUND	1
7	4013034	SASS CABLE PARK BATTERY PACK	1



# 17.2 ELECTRICAL COMPONENTS – Power Unit Battery 12v

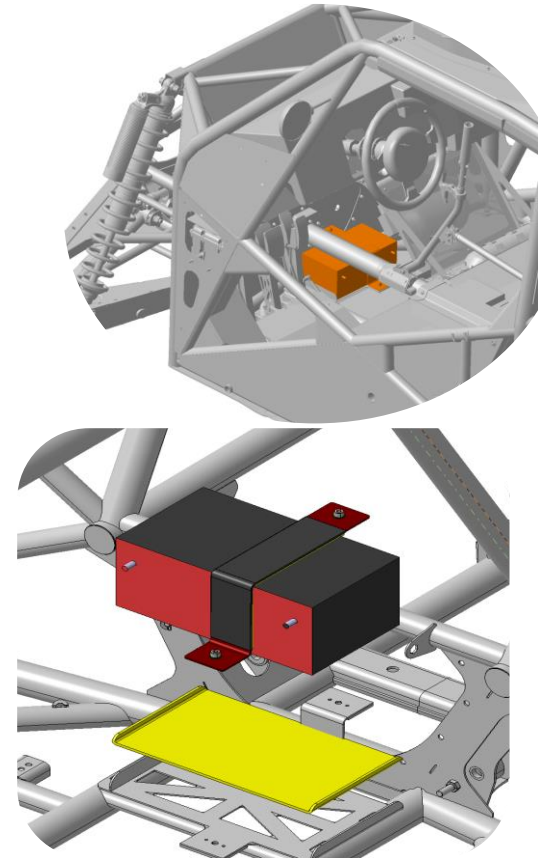
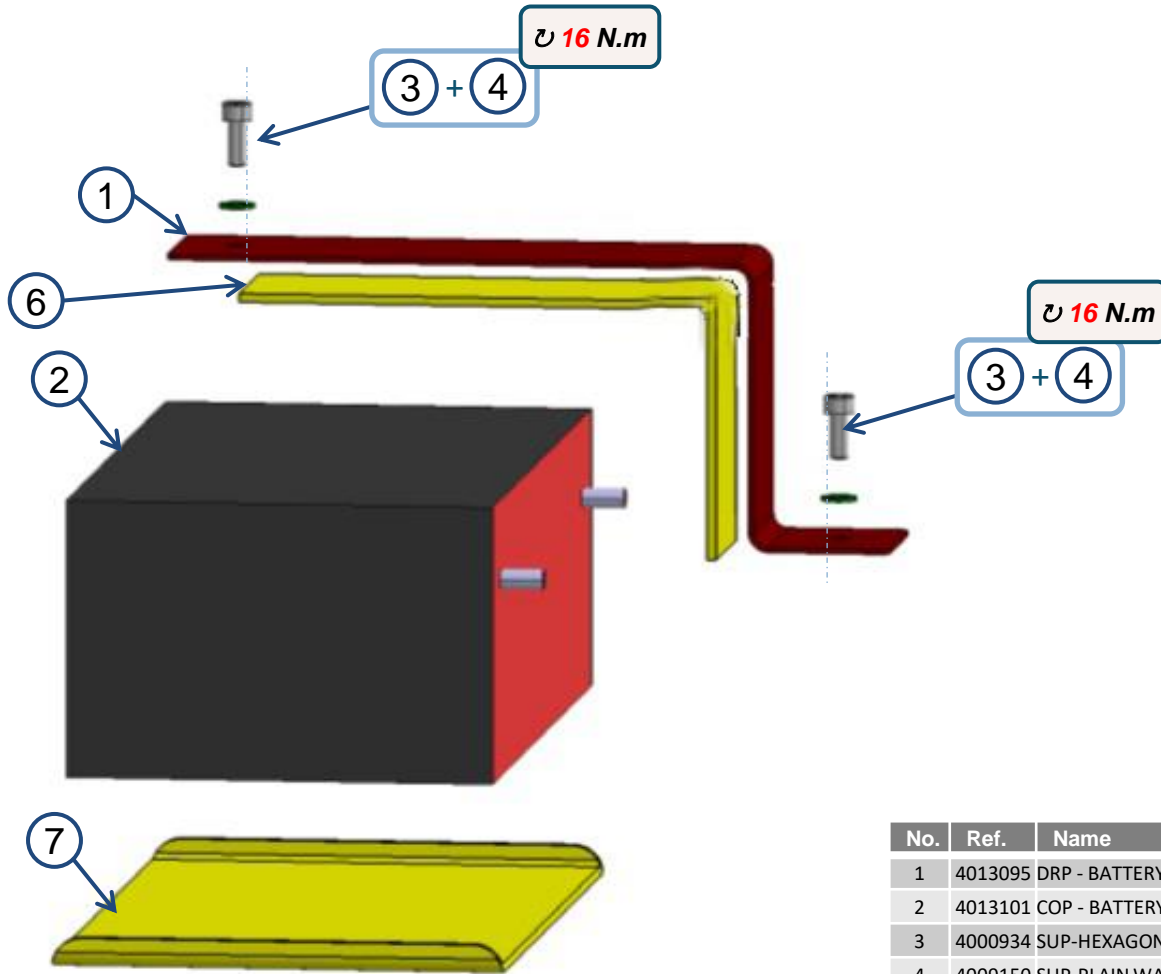

**N° to update**

No.	Ref.	Name	Qty.
1	4013095	DRP - BATTERY BELT	1
2	4013101	COP - BATTERY LITHIUM SUPER B 23AH 1500A - 1SB25P	1
3	4000934	SUP-HEXAGONAL SOCKET CAP SCREW ISO 4762 M6X16-16 P100 CL12.9 A B	2
4	4009150	SUP-PLAIN WASHER D6XD12X1.2 TYPE Z NFE25-514 A EZ	2
6		DRP-INSULANT PLATE POLYURETHANE 3MM 60SHA RECUT 230x50MM	1
7	4018267	DRP-INSULANT PLATE POLYURETHANE 3MM 60SHA RECUT 270x150MM	1

# 17.3.1 ELECTRICAL COMPONENTS – Management System – Master Switch

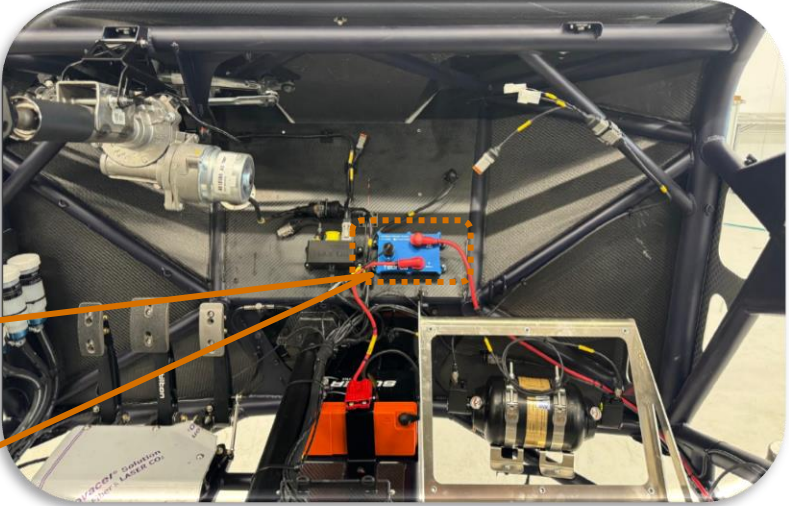

No.	Ref.	Name	Qty.
1	4013072	COP – MASTER SWITCH HP8480	1
2	4012692	ANTI-VIBRATION STUD M5 Ø16X10	4
3	4016944	SUP-LOCKNUT WITH FLANGE – M5X0.8 – SIMMONDS	4
4	4008176	SUP-BUTTON HEAD SCREW ISO 7380 M5X10-10 P80 CL10.9	4
5	4021816	COP RED THERMINAL BOOT	2

## 17.3.2 ELECTRICAL COMPONENTS – Junction box V1.0

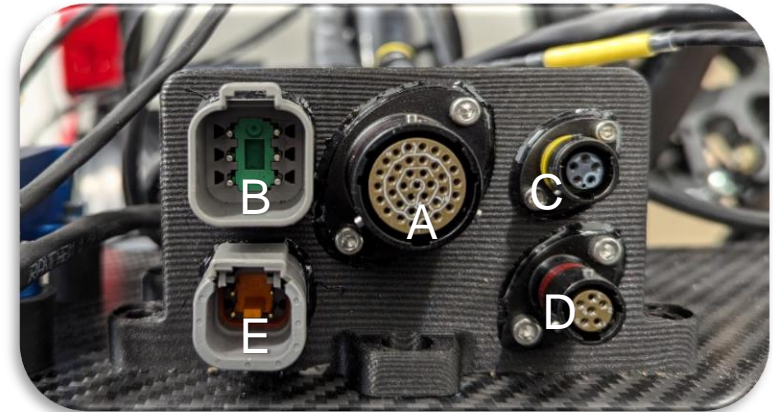
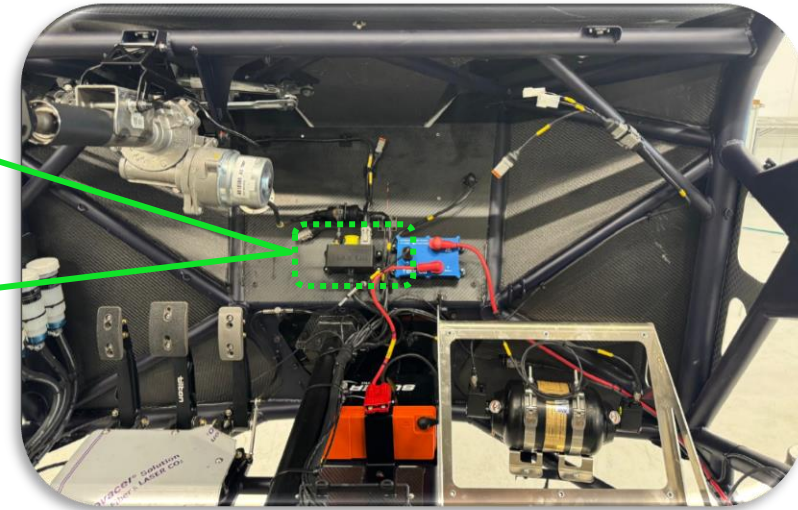

- A Dashboard
- B Wipers
- C Front Brake Pressure
- D Throttle Position
- E Spare 12V

No.	Ref.	Name	Qty.
1	4018906	SASS-HARNESS FRONT CHASSIS	1
2	4000906	SUP-HEXAGONAL SOCKET CAP SCREW ISO 4762 M5X12-12 P80 CL12.9	4
3	4016944	SUP-LOCKNUT WITH FLANGE – M5X0.8 – SIMMONDS	4

# 17.3.3 ELECTRICAL COMPONENTS – Wiper connector

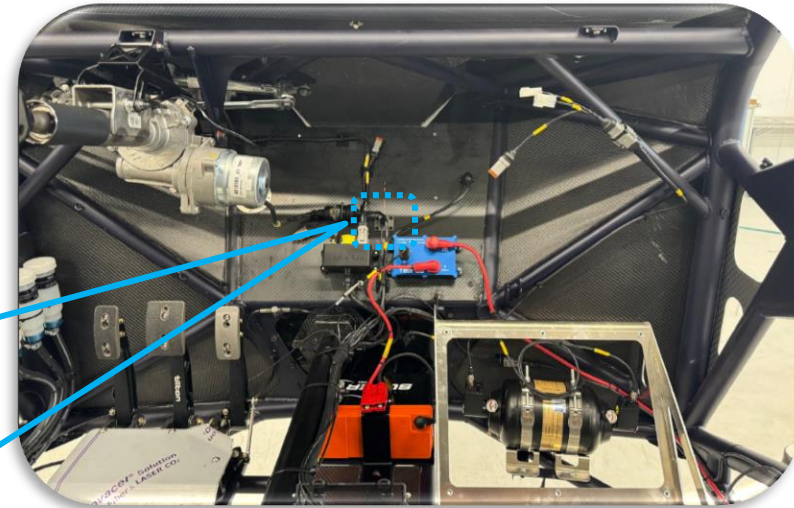
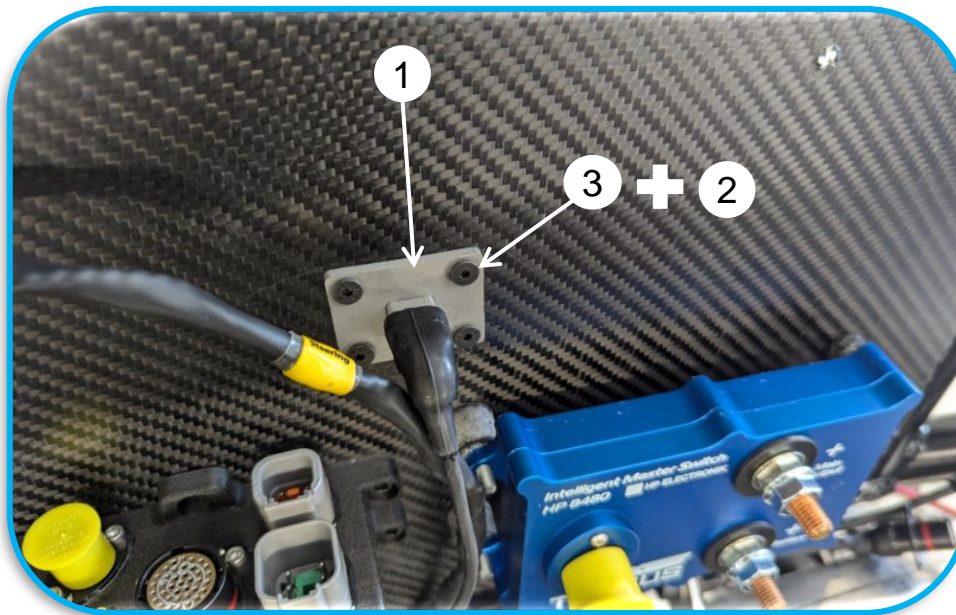

No.	Ref.	Name	Qty.
1	4018906	SASS-HARNESS FRONT CHASSIS	1
2		SUP-FHC SCREW M4X12 CL12.9	4
3	4012559	SUP-LOCKNUT DIN 985 M4 P070 CL6.8 NYLSTOP	4

# 17.3.4.1 ELECTRICAL COMPONENTS – Management System – PDM HP

8442 – SRG 141

Aluminium fuel tank

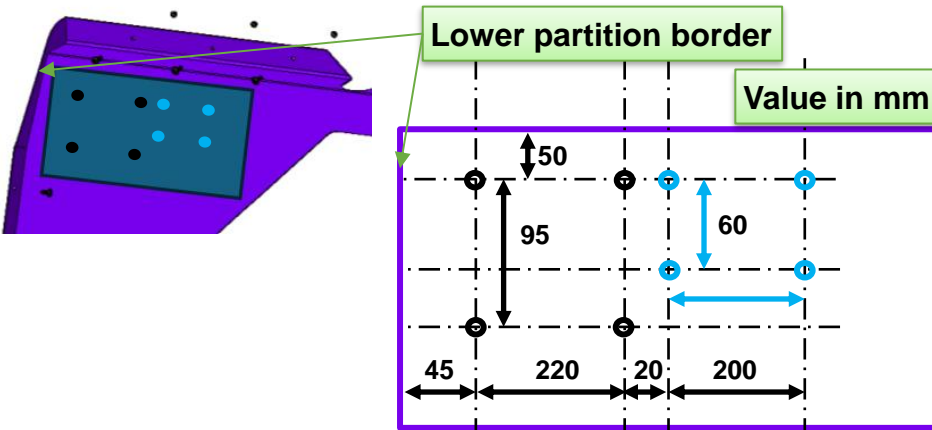
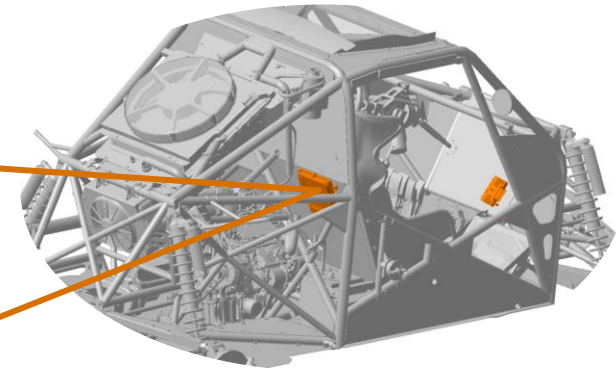
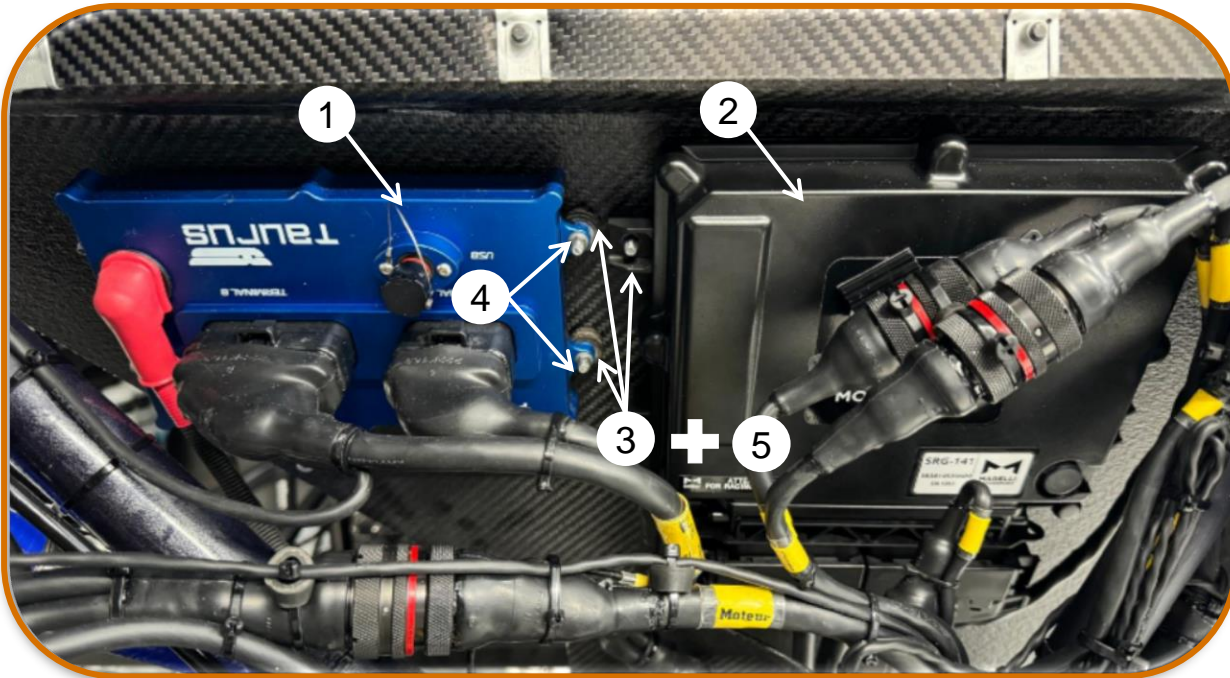

No.	Ref.	Name	Qty.
1	4018913	COP – POWERBOX HP8442	1
2	4013263	COP-ELECTRONIC CONTROL UNIT (ECU) SRG 141	1
3	4012692	ANTI-VIBRATION STUD M5 Ø16X10	8
4	4016944	SUP-LOCKNUT WITH FLANGE – M5X0.8 – SIMMONDS	8
5	4008176	SUP-BUTTON HEAD SCREW ISO 7380 M5X10-10 P80 CL10.9	8

# 17.3.4.2 ELECTRICAL COMPONENTS – Management System – PDM HP

8442 – SRG 141

**Composite fuel tank**

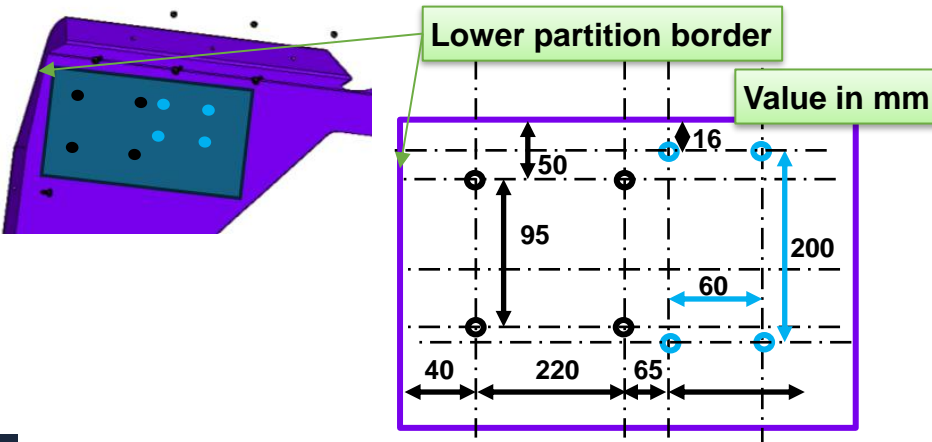
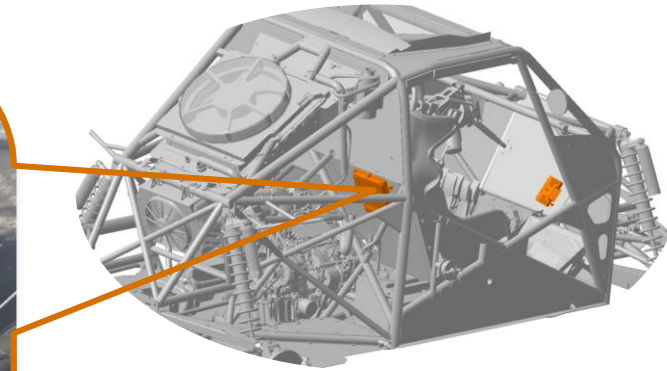
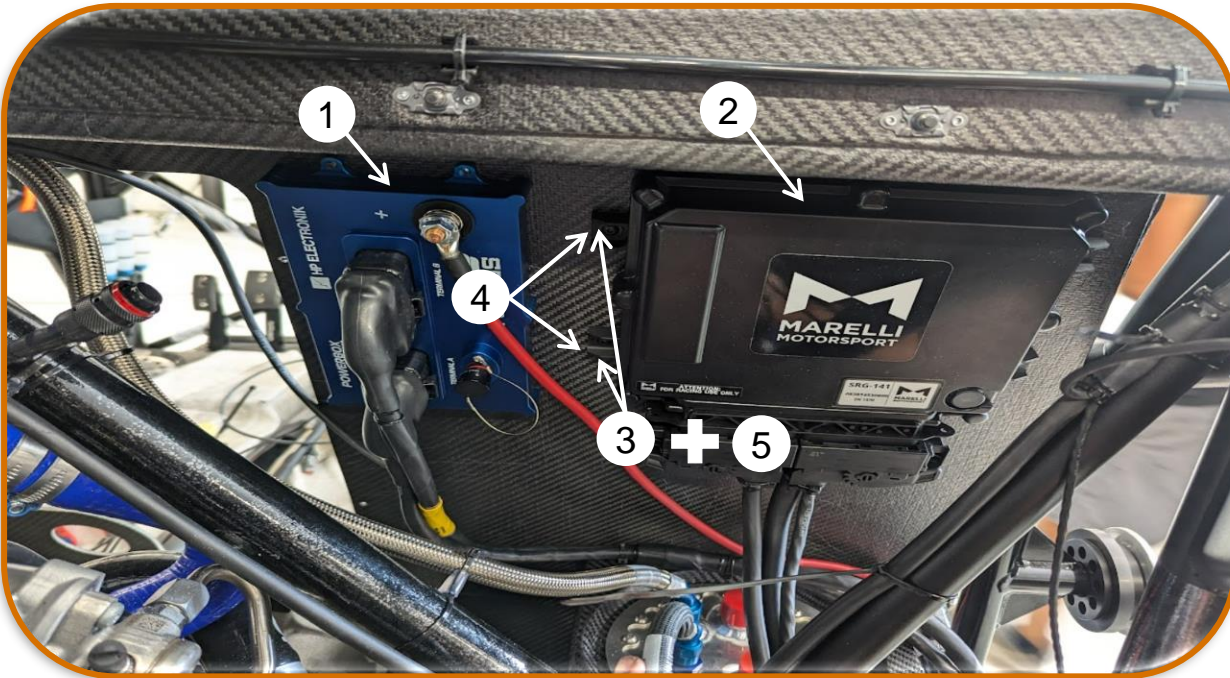

No.	Ref.	Name	Qty.
1	4018913	COP – POWERBOX HP8442	1
2	4013263	COP-ELECTRONIC CONTROL UNIT (ECU) SRG 141	1
3	4012692	ANTI-VIBRATION STUD M5 Ø16X10	8
4	4016944	SUP-LOCKNUT WITH FLANGE – M5X0.8 – SIMMONDS	8
5	4008176	SUP-BUTTON HEAD SCREW ISO 7380 M5X10-10 P80 CL10.9	8

# 17.4.1 ELECTRICAL COMPONENTS – Front Loom – EV1

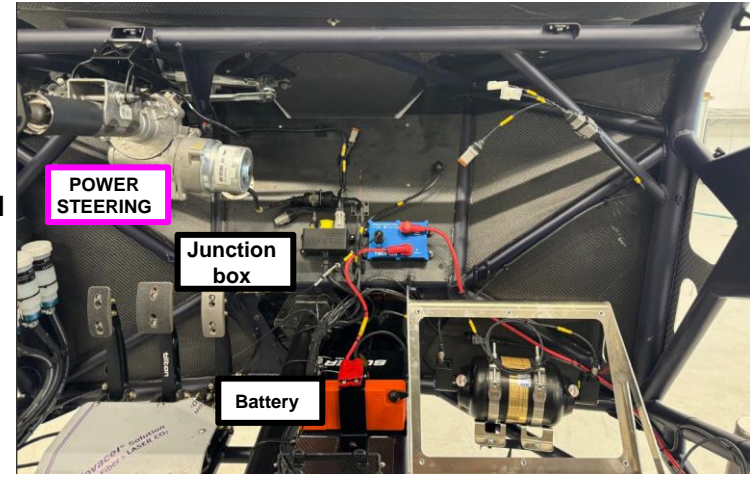
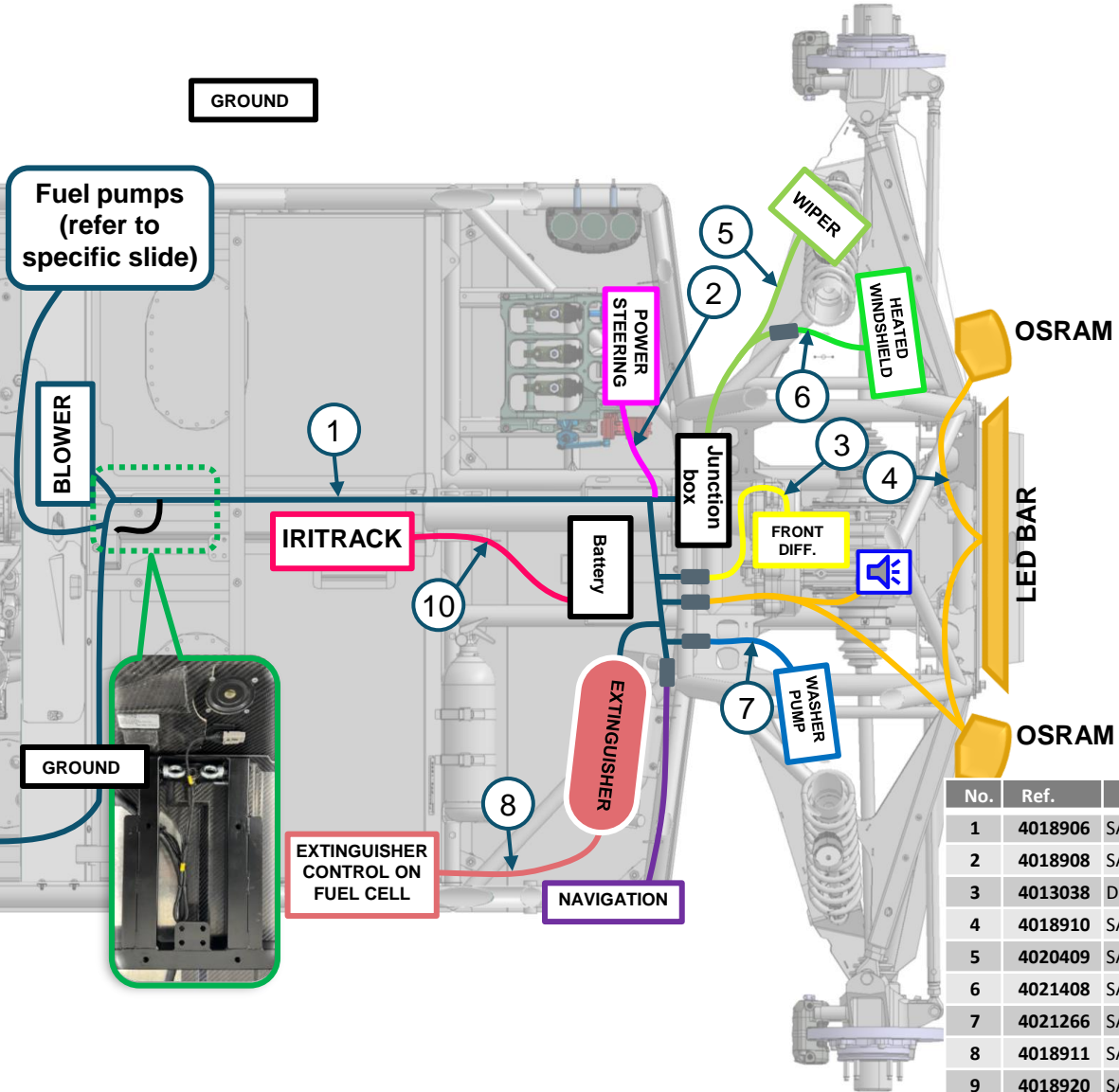

No.	Ref.	Name	Qty.
1	4018906	SASS-HARNESS FRONT CHASSIS	1
2	4018908	SASS-HARNESS WIRED DACIA POWER STEERING WITH STEERING POSITION	1
3	4013038	DRP-WIRING HARNESS, FRONT DIFF	1
4	4018910	SASS-HARNESS FRONT BONNET	1
5	4020409	SASS-WIRING WIPER LOOM	1
6	4021408	SASS-TO BE DEFINED HEATED WINDSHIELD	1
7	4021266	SASS-WIRING Y LOOM WINDSHIELD WATER PUMP	1
8	4018911	SASS-HARNESS EXTINGUISHER	1
9	4018920	SASS-HARNESS NAVIGATION	1
10	4013049	DRP-WIRING HARNESS, IRITRACK POWER SUPPLY	1

# 17.4.2 ELECTRICAL COMPONENTS – Front Loom – Under dashboard installation

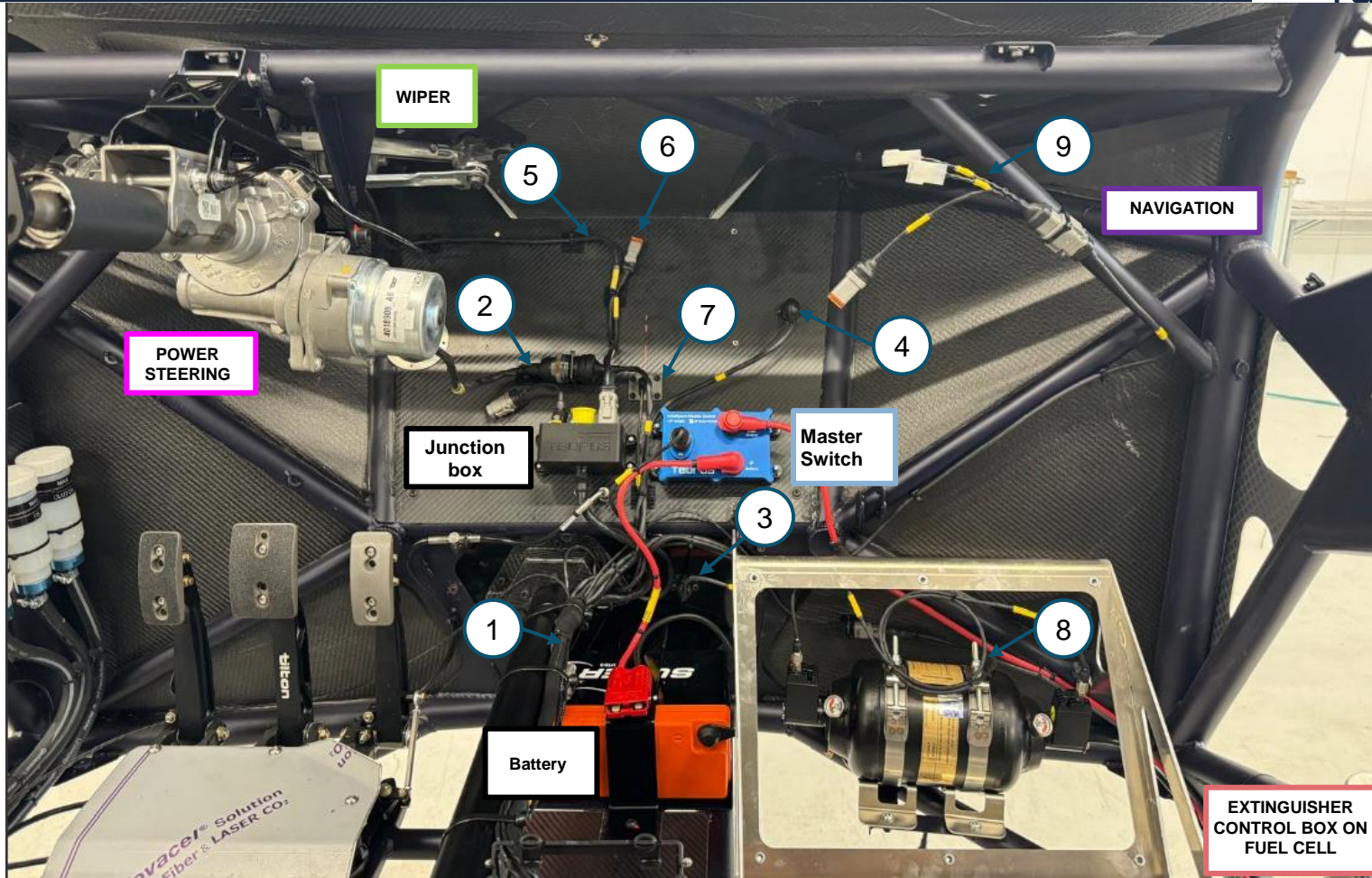

No.	Ref.	Name	Qty.
1	4018906	SASS-HARNESS FRONT CHASSIS	1
2	4018908	SASS-HARNESS WIRED DACIA POWER STEERING WITH STEERING POSITION	1
3	-	FRONT DIFF CONNECTOR	1
4	-	FRONT BONNET BULKHEAD CONNECTOR	1
5	4020409	SASS-WIRING WIPER LOOM	1

No.	Ref.	Name	Qty.
6	-	HEATED WINDSHIELD CONNECTOR	1
7	-	WATER PUMP CONNECTOR	1
8	4018911	SASS-HARNESS EXTINGUISHER	1
9	4018920	SASS-HARNESS NAVIGATION	1



## 17.4.3 ELECTRICAL COMPONENTS – Front Loom – Iritrak assembly

### Aluminium fuel tank

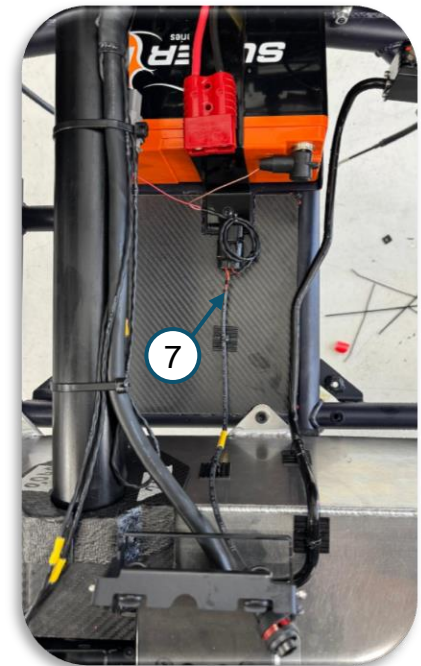
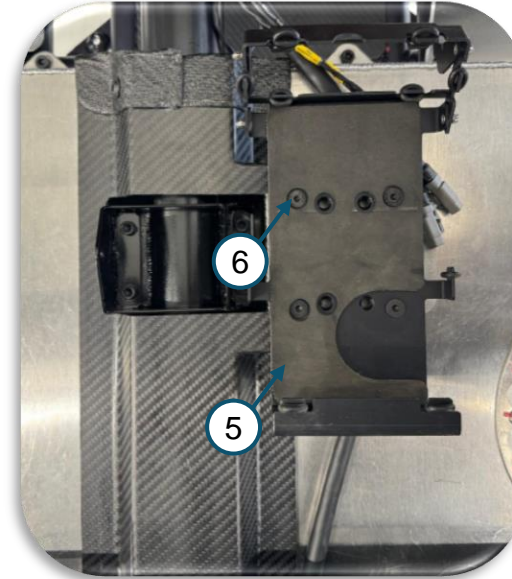
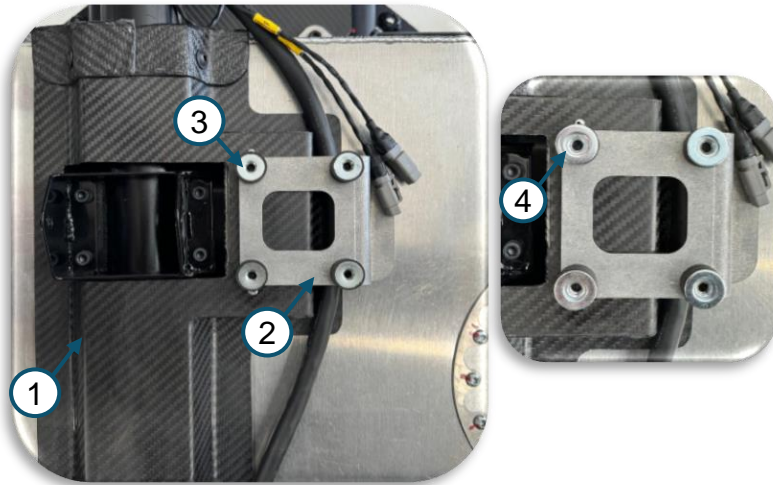

### On the roof



No.	Ref.	Name	Qty.
1	4020190	CARBON PROTECTION FUEL CELL REWORKED WITH FLOATING NUTS	1
2	4010235	IRITRACK BRACKET	1
3		SILENT BLOC	4
4		1,6mm THICKNESS WASHER	4
5	4020235	MARLINK IRITRACK BRACKET (S0140)	1
6	4021408	SUP-HEXAGON SOCKET COUNTERSUNK HEAD CAP SCREW M5X12-9 P80 CL12.9 ISO10642 A B	4
7	4013049	IRITRACK POWER HARNESS	1
8	4018444	GPS ANTENNA WITH 3 M CABLE	1
9	4018441	IRIDIUM ANTENNA	1

# 17.4.4 ELECTRICAL COMPONENTS – Front Loom – Iritrak assembly



**Composite fuel tank**

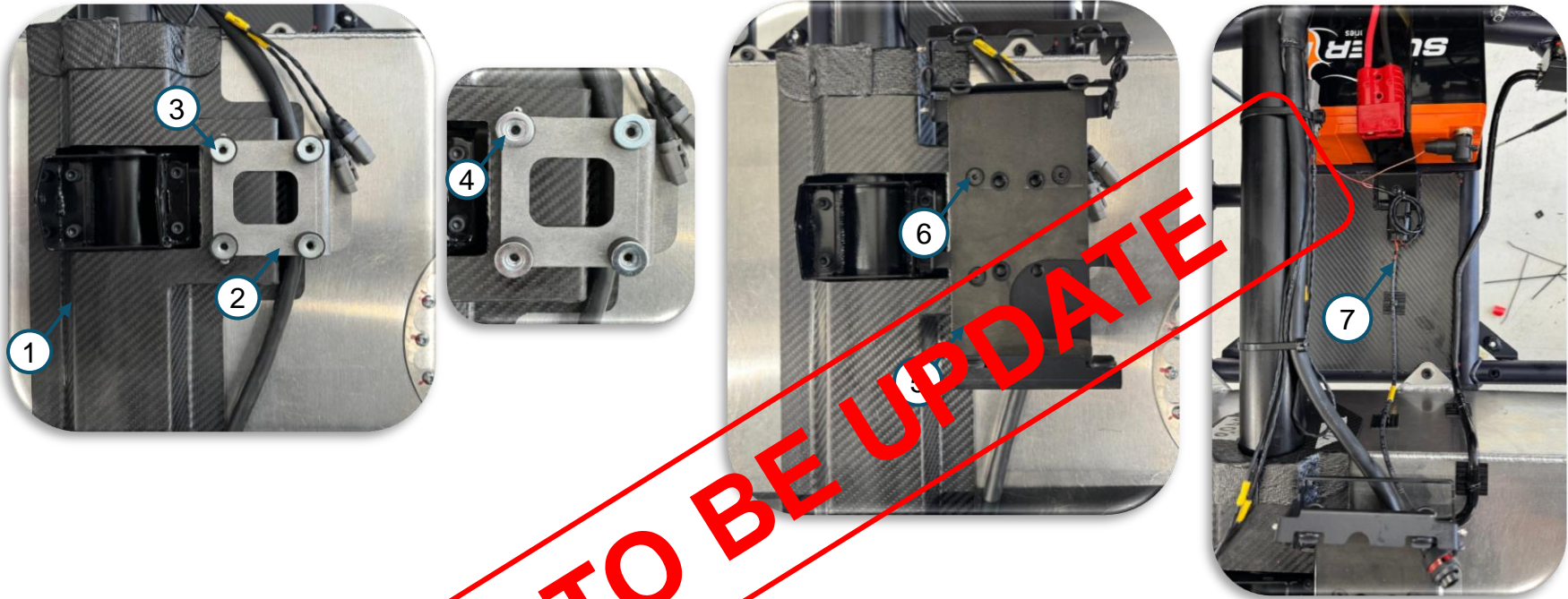

**TO BE UPDATE**

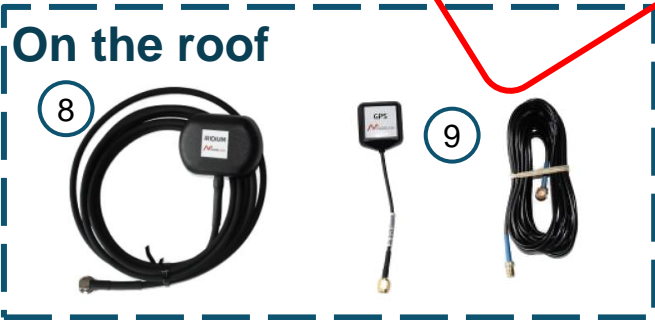

No.	Ref.	Name	Qty.
1	4020190	CARBON PROTECTION FUEL CELL REWORKED WITH FLOATING NUTS	1
2	4010235	IRITRACK BRACKET	1
3		SILENT BLOC	4
4		1,6mm THICKNESS WASHER	4
5	4020235	MARLINK IRITRACK BRACKET (S0140)	1
6	4021408	SUP-HEXAGON SOCKET COUNTERSUNK HEAD CAP SCREW M5X12-9 P80 CL12.9 ISO10642 A B	4
7	4013049	IRITRACK POWER HARNESS	1
8	4018444	GPS ANTENNA WITH 3 M CABLE	1
9	4018441	IRIDIUM ANTENNA	1

# 17.5.1 ELECTRICAL COMPONENTS – Rear Loom – EV1



**Bulkhead fixed to chassis**

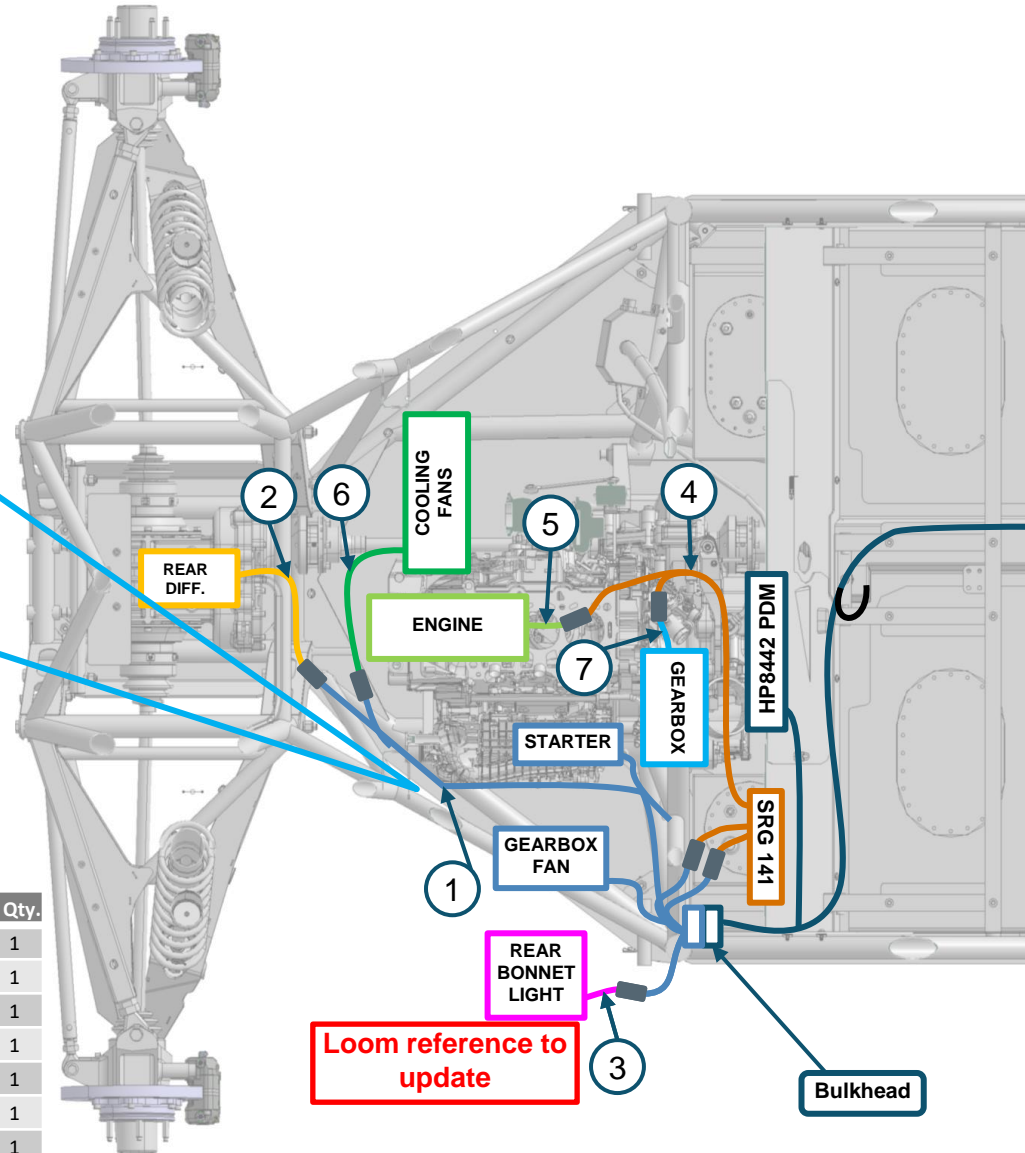

No.	Ref.	Name	Qty.
1	4018907	SASS-HARNESS REAR CHASSIS	1
2	4020406	SASS-HARNESS REAR DIFFERENTIAL	1
3	4021303	SASS-HARNESS REAR BONNET LIGHT	1
4	4018916	SASS-HARNESS MARELLI ECU	1
5	4018914	SASS-HARNESS ENGINE	1
6	4013041	DRP-WIRING HARNESS, REAR GMV	1
7	4018917	SASS-HARNESS GEARBOX	1

## 17.5.2 ELECTRICAL COMPONENTS – Gearbox fan

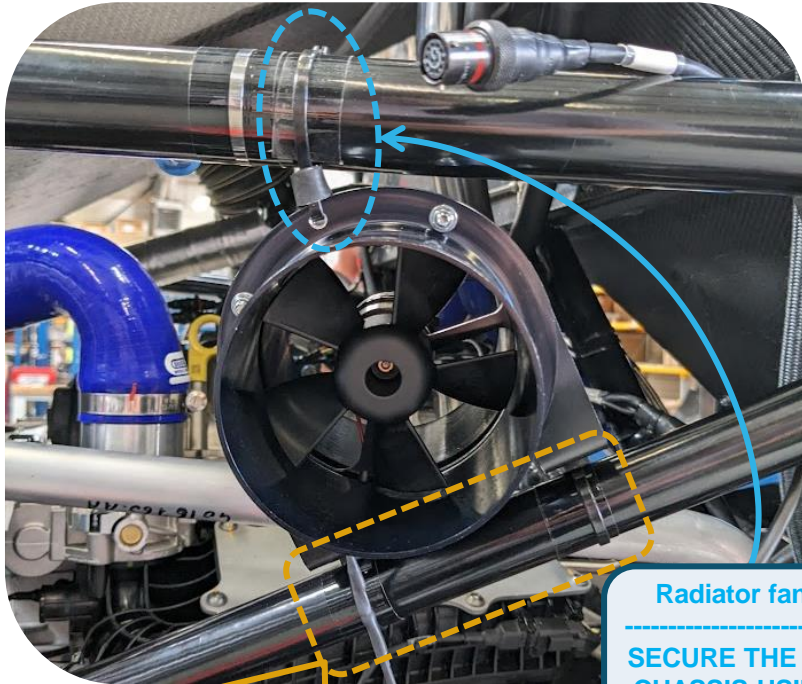

Radiator fan assembly

SECURE THE FAN TO THE CHASSIS USING XXX (ZIP TIE + )

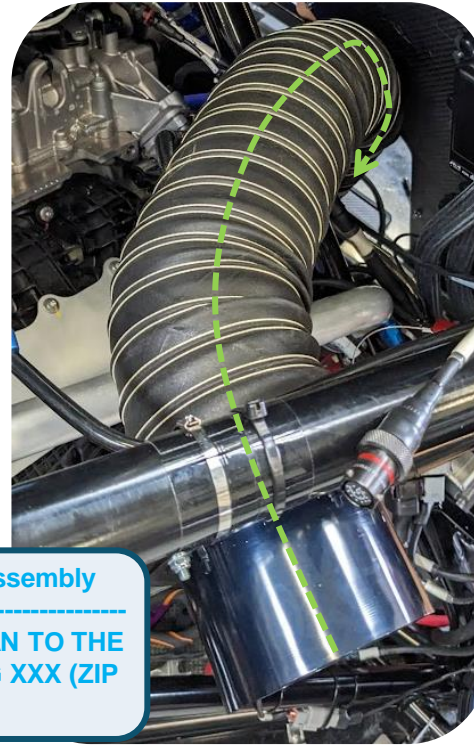

Radiator fan assembly

FAN VENTILATION HAS TO BE POINTED TOWARDS GEARBOX

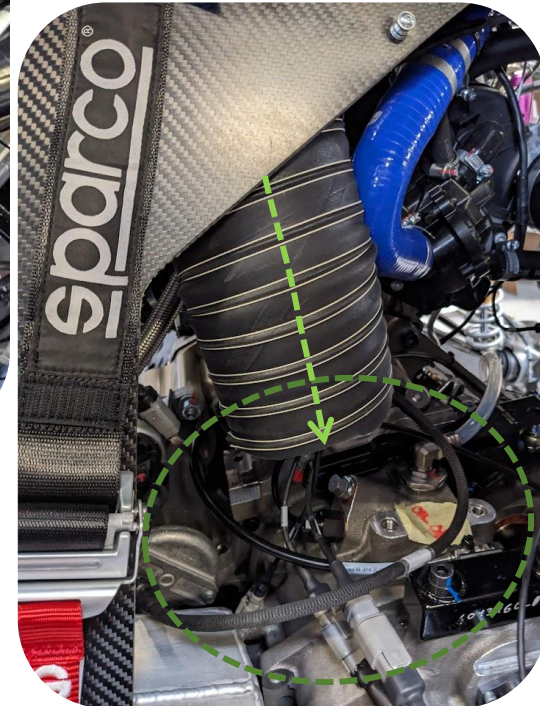
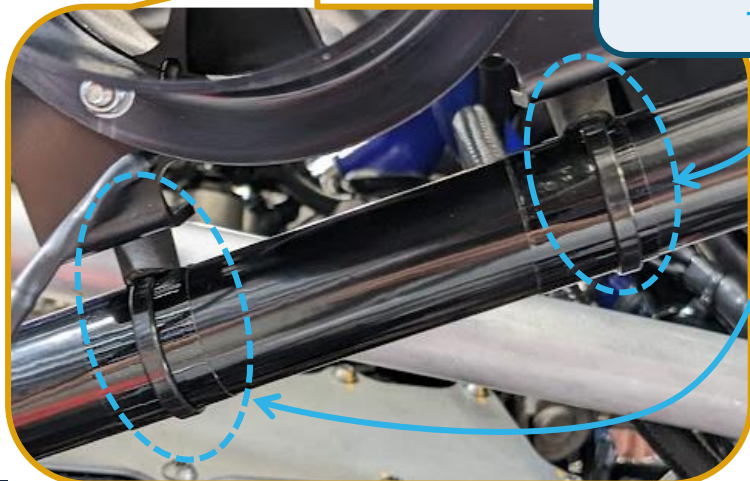

No.	Ref.	Name	Qty.
1	4016875	SASS-WIRED GEARBOX FAN	1
2	4016550	COP-DUCT VENTILATION Ø102 INT L700MM NEOPRENE	1

# 17.5.3 ELECTRICAL COMPONENTS – Engine– 2024 Spec – Loom set-up

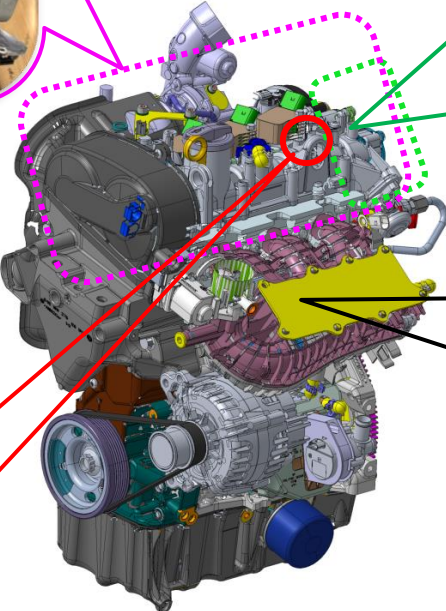

**1**

**2**

**Coils Ground**

**Injectors and alternator connectors**

No.	Ref.	Name	Qty.
1	4018914	SASS HARNESS, VW Engine 2024	1
2	4020407	VW COILS Harness	1

# 17.6 ELECTRICAL COMPONENTS – Front Loom – EV2

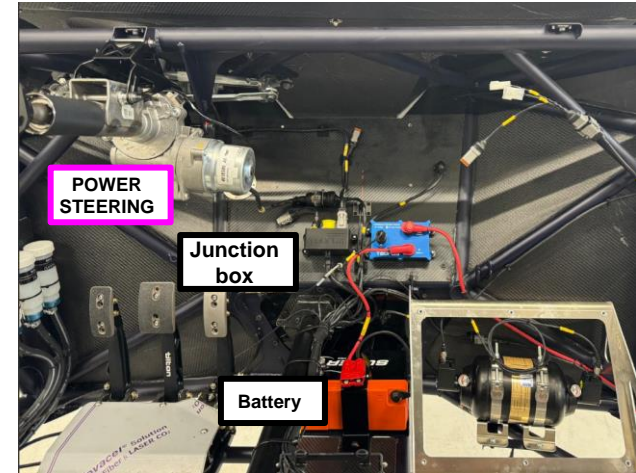
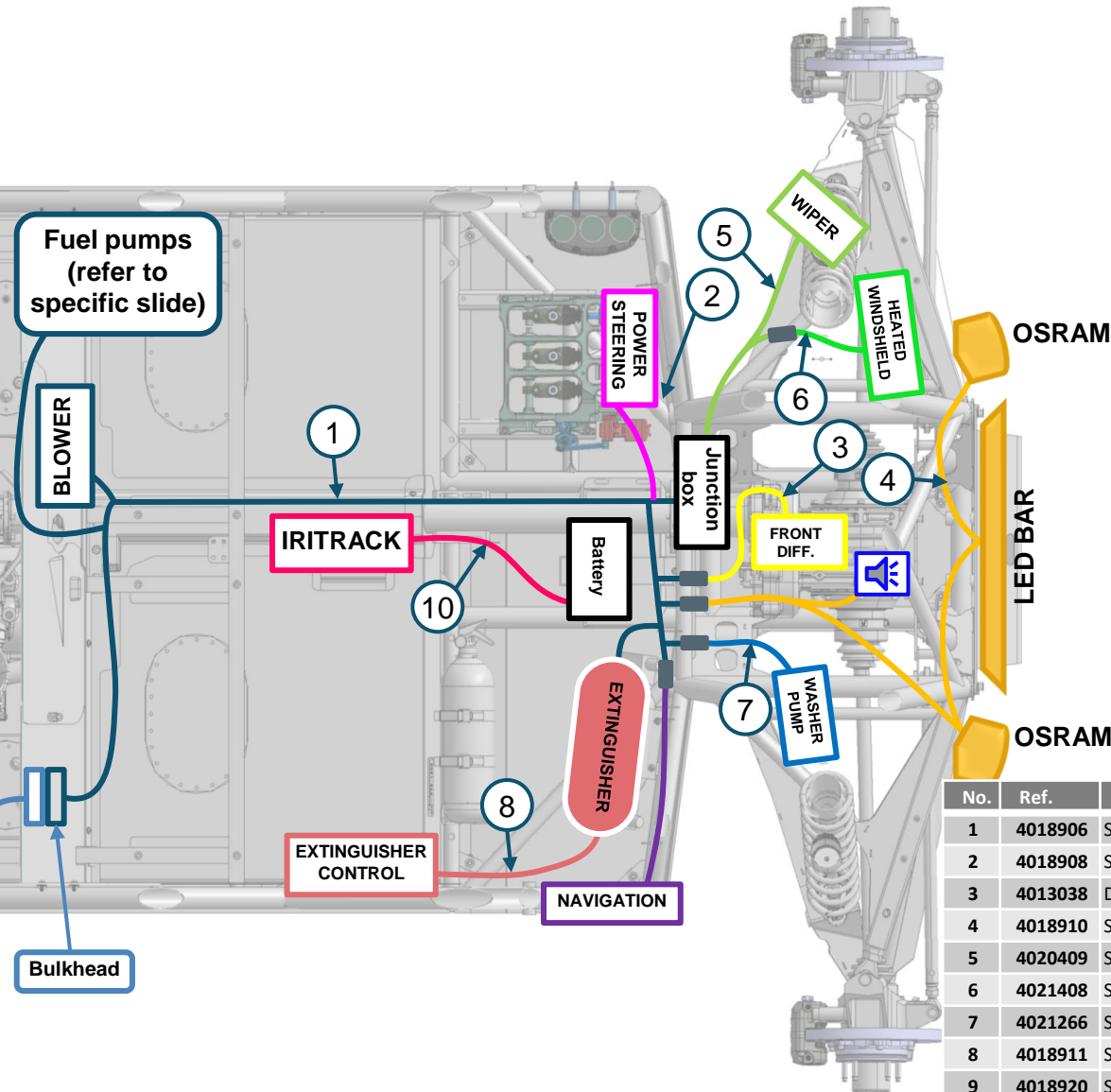

No.	Ref.	Name	Qty.
1	4018906	SASS-HARNES FRONT CHASSIS	1
2	4018908	SASS-HARNES WIRED DACIA POWER STEERING WITH STEERING POSITION	1
3	4013038	DRP-WIRING HARNES, FRONT DIFF	1
4	4018910	SASS-HARNES FRONT BONNET	1
5	4020409	SASS-WIRING WIPER LOOM	1
6	4021408	SASS-TO BE DEFINED HEATED WINDSHIELD	1
7	4021266	SASS-WIRING Y LOOM WINDSHIELD WATER PUMP	1
8	4018911	SASS-HARNES EXTINGUISHER	1
9	4018920	SASS-HARNES NAVIGATION	1
10	4013049	DRP-WIRING HARNES, IRITRACK POWER SUPPLY	1

# 17.7 ELECTRICAL COMPONENTS – Rear Loom – EV2



**ADD PICTURE OF ENGINE**

**ADD PICTURE OF BULKHEAD**

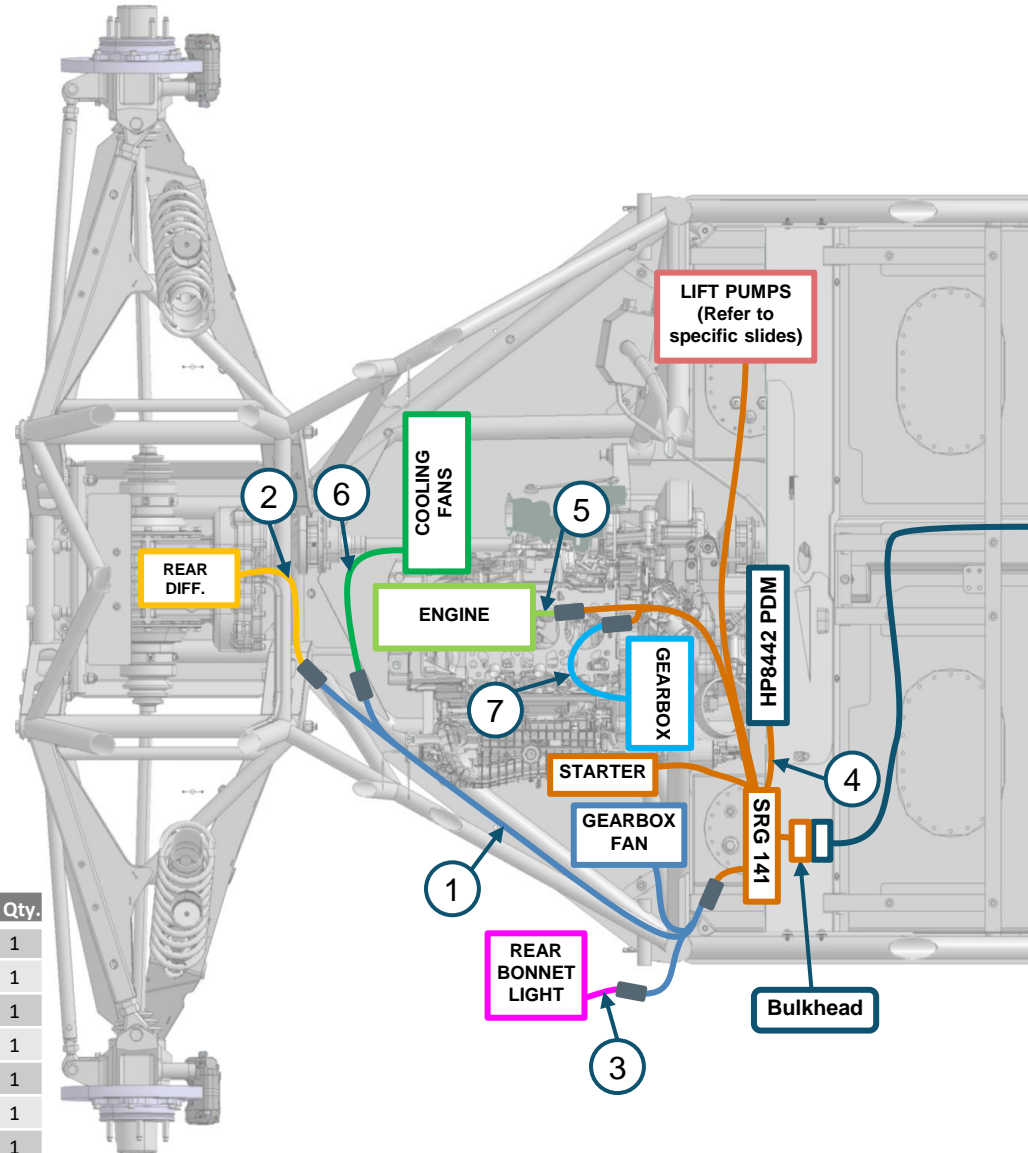

No.	Ref.	Name	Qty.
1	4021422	SASS-HARNESS REAR CHASSIS	1
2	4020406	SASS-HARNESS REAR DIFFERENTIAL	1
3	4021303	SASS-HARNESS REAR BONNET LIGHT	1
4	4021421	SASS-HARNESS MARELLI ECU	1
5	4018914	SASS-HARNESS ENGINE	1
6	4013041	DRP-WIRING HARNESS, REAR GMV	1
7	4018917	SASS-HARNESS GEARBOX	1

# 17.8.1 ELECTRICAL COMPONENTS – Dashboard

**TAURUS PDM PMU 16**

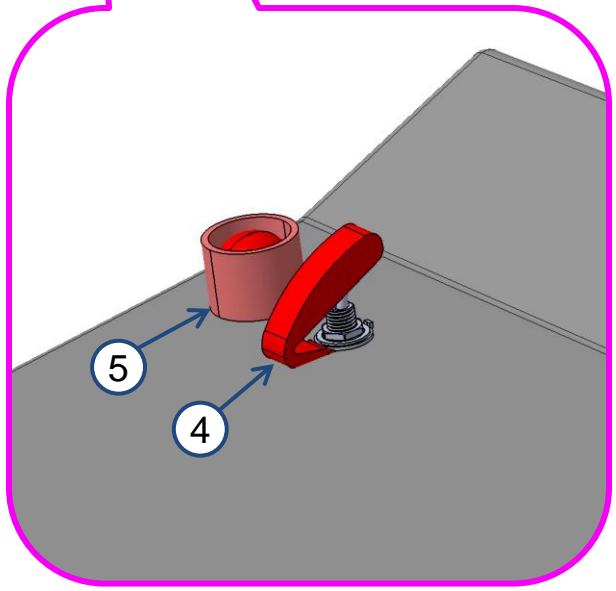
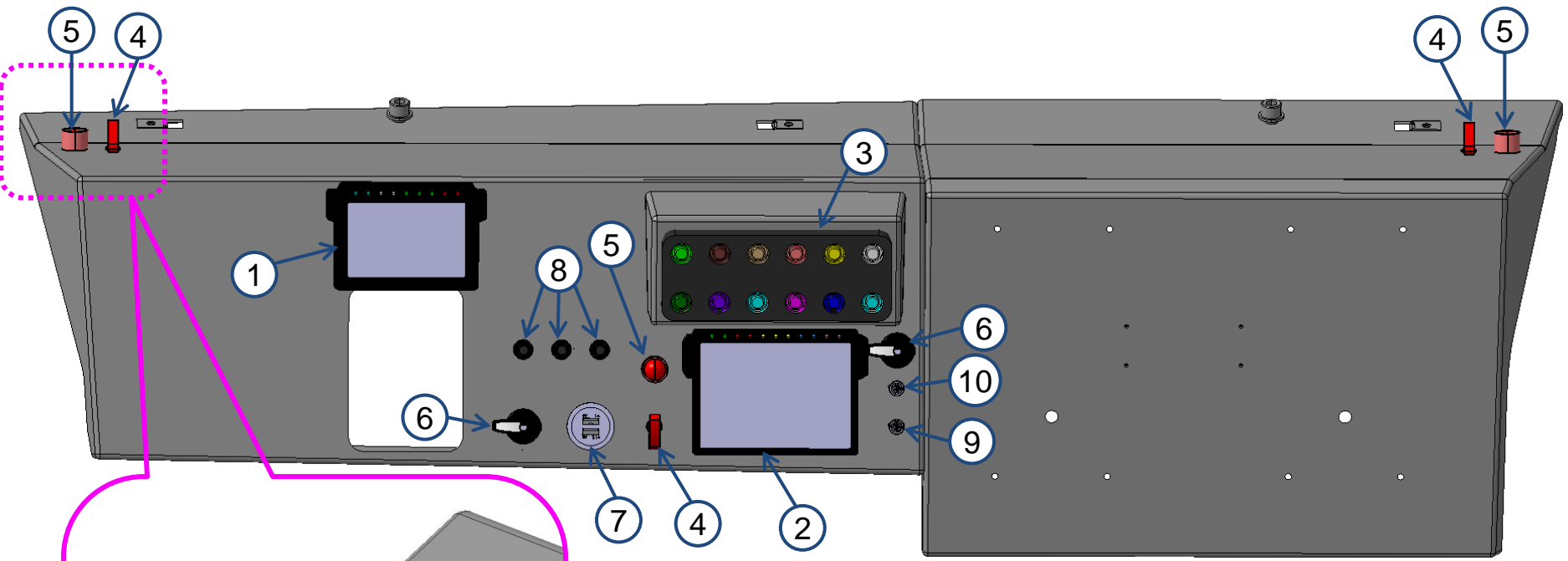

No.	Ref.	Name	Qty.
1	4013311	COP-DISPLAY SDM 330 D	1
2	4013312	COP-DISPLAY SDM 550 DLG	1
3	4018042	SASS-WIRING KEYPAD 12K	1
4	4020349	MAIN ON OFF SAFETY SWITCH 1V-2P	3
5	4016575	SASS-WIRING EXTINGUER BUTTON	3
6	4019937	SASS-WIRING MAP OR SPEED LIMITOR ROTACTOR	2
7	4017463	SASS-WIRING USB	1
8	4016959	COP-CONNECTOR BREAKER 2CT2-4 LINE MS3320-4 1202 FNR: CAMBRIDGE TECHNOLOGY	3
9	4020412	SPEED LIMITER ON OFF	1
10	4020411	SPEED LIMIT ADJUSTER +/-	1



## 17.8.2 ELECTRICAL COMPONENTS – Dashboard – Keypad

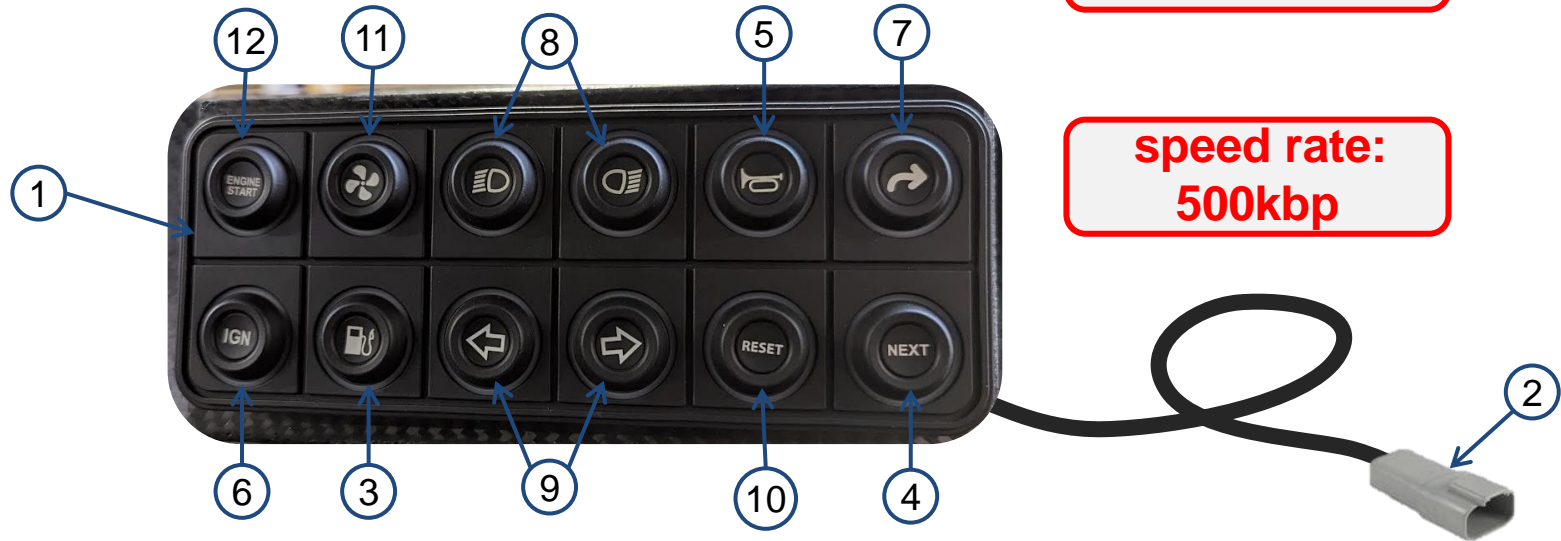

**! PDM PMU 16**

**speed rate:  
500kbp**

No.	Ref.	Name	Qty.
1	4013077	MCE-COP-TO BE DEFINED CAN KEYPAD 12K	1
2	4016616	MCE-COP-CONNECTOR DT04-4P	1
3	4018730	MCE-SUP-MATERIAL PKP INSERT, 15MM, FUEL PUMP, GAS	1
4	4018731	MCE-SUP-MATERIAL PKP INSERT, 15MM, NEXT	1
5	4018732	MCE-SUP-MATERIAL PKP INSERT, 15MM, HORN	1
6	4018733	MCE-SUP-MATERIAL PKP INSERT, 15MM, IGNITION	1
7	4018734	MCE-SUP-MATERIAL PKP INSERT, 15MM, ENTER ARROW	1
8	4018735	MCE-SUP-MATERIAL PKP INSERT, 15MM, HEAD LIGHT	2
9	4018736	MCE-SUP-MATERIAL PKP INSERT, 15MM, ARROW	2
10	4018737	MCE-SUP-MATERIAL PKP INSERT, 15MM, RESET	1
11	4018739	MCE-SUP-MATERIAL PKP INSERT, 15MM, FAN	1
12	4018740	MCE-SUP-MATERIAL PKP INSERT, 15MM, ENGINE START	1

# 17.9.1 ELECTRICAL COMPONENTS – Dashboard 2024

PDM HP 8442

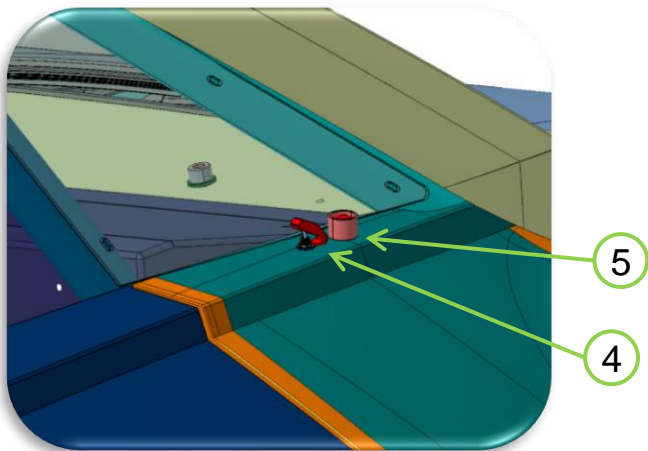
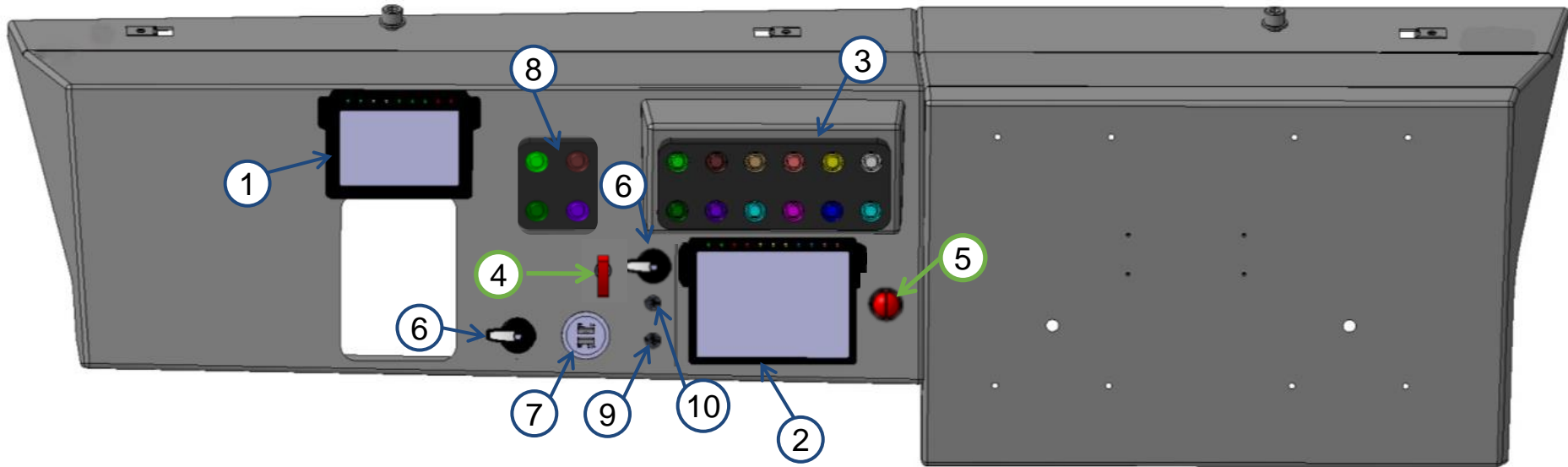

No.	Ref.	Name	Qty.
1	4013311	COP-DISPLAY SDM 330 D	1
2	4013312	COP-DISPLAY SDM 550 DLG	1
3	4018042	SASS-WIRING KEYPAD 12K	1
4	4020349	MAIN ON OFF SAFETY SWITCH 1V-2P	3
5	4016575	SASS-WIRING EXTINGUER BUTTON	3
6	4019937	SASS-WIRING MAP OR SPEED LIMITOR ROTACTOR	2
7	4017463	SASS-WIRING USB	1
8	4020997	SASS-WIRING KEYPAD 4K	1
9	4020412	SPEED LIMITER ON OFF	1
10	4020411	SPEED LIMIT ADJUSTER +/-	1

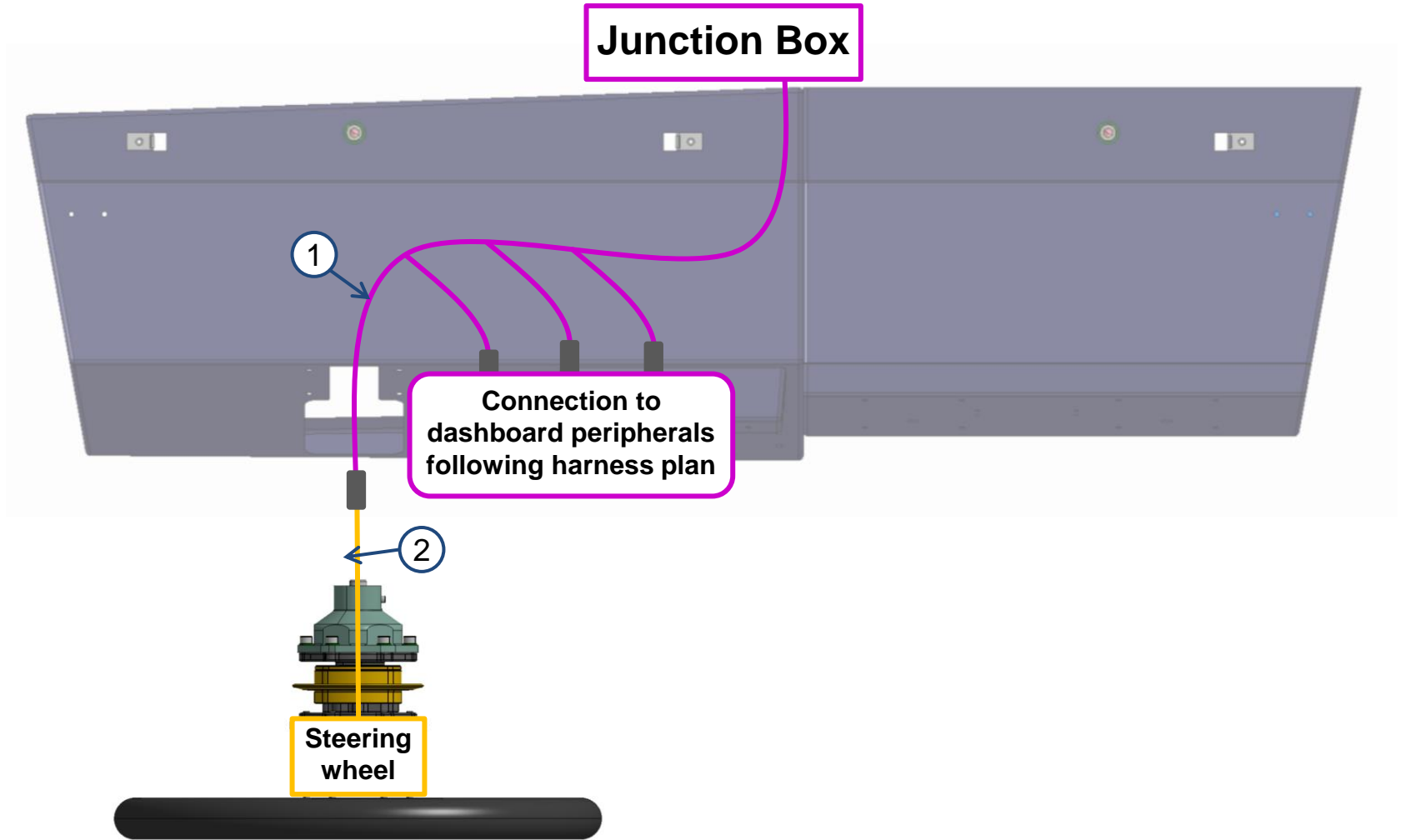

No.	Ref.	Name	Qty.
1	4021302	SASS-HARNESS DASHBOARD	1
2	4018909	SASS-HARNESS STEERING WHEEL	1

## 17.9.3 ELECTRICAL COMPONENTS – Dashboard – Keypad 12 keys

PDM HP 8442

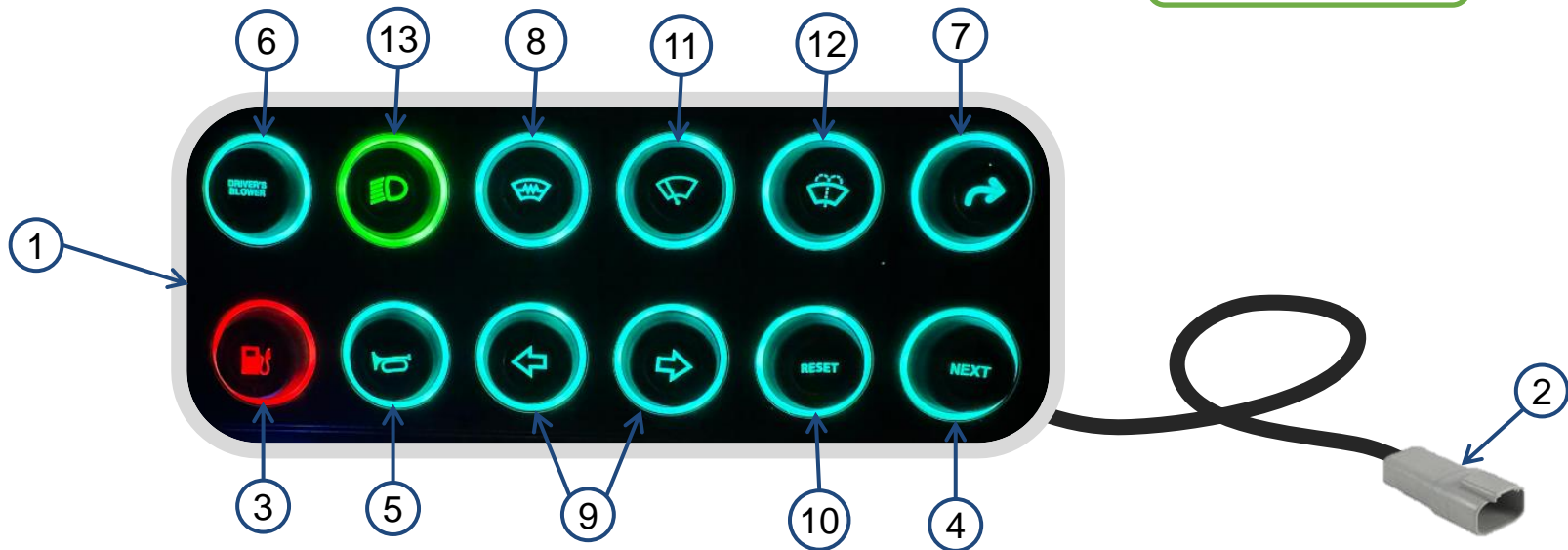

No.	Ref.	Name	Qty.
1	4013077	COP-TO BE DEFINED CAN KEYPAD 12K	1
2	4016616	COP-CONNECTOR DT04-4P	1
3	4018730	SUP-MATERIAL PKP INSERT, 15MM, FUEL PUMP, GAS	1
4	4018731	SUP-MATERIAL PKP INSERT, 15MM, NEXT	1
5	4018732	SUP-MATERIAL PKP INSERT, 15MM, HORN	1
6	4021424	SUP-MATERIAL PKP INSERT, 15MM, DRIVER'S BLOWER	1
7	4018734	SUP-MATERIAL PKP INSERT, 15MM, ENTER ARROW	1
8	4021425	SUP-MATERIAL PKP INSERT, 15MM, HEATED WINDSHIELD	1
9	4018736	SUP-MATERIAL PKP INSERT, 15MM, ARROW	2
10	4018737	SUP-MATERIAL PKP INSERT, 15MM, RESET	1
11	4021426	SUP-MATERIAL PKP INSERT, 15MM, WIPER	1
12	4021427	SUP-MATERIAL PKP INSERT, 15MM, WIPER WASH	1
13	4018735	MCE-SUP-MATERIAL PKP INSERT, 15MM, HEAD LIGHT	1

# 17.9.3 ELECTRICAL COMPONENTS – Dashboard – Keypad 4 keys



**PDM HP 8442**

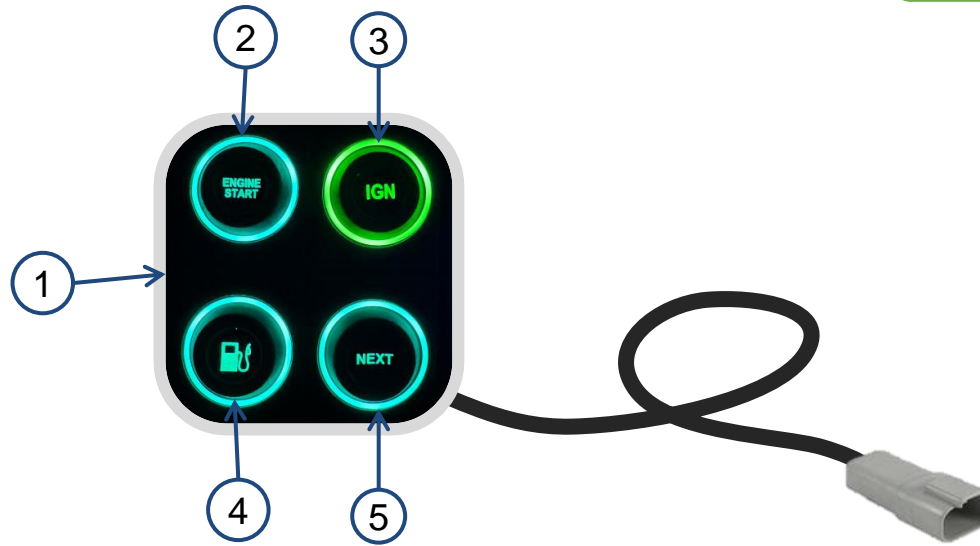

No.	Ref.	Name	Qty.
1	4020997	MCE-COP-TO BE DEFINED CAN KEYPAD 4K	1
2	4018740	MCE-SUP-MATERIAL PKP INSERT, 15MM, ENGINE START	1
3	4018733	MCE-SUP-MATERIAL PKP INSERT, 15MM, IGNITION	1
4	4018730	SUP-MATERIAL PKP INSERT, 15MM, FUEL PUMP, GAS	1
5	4018731	SUP-MATERIAL PKP INSERT, 15MM, NEXT	1

## 17.9.4 ELECTRICAL COMPONENTS – Dashboard – Loom set-up

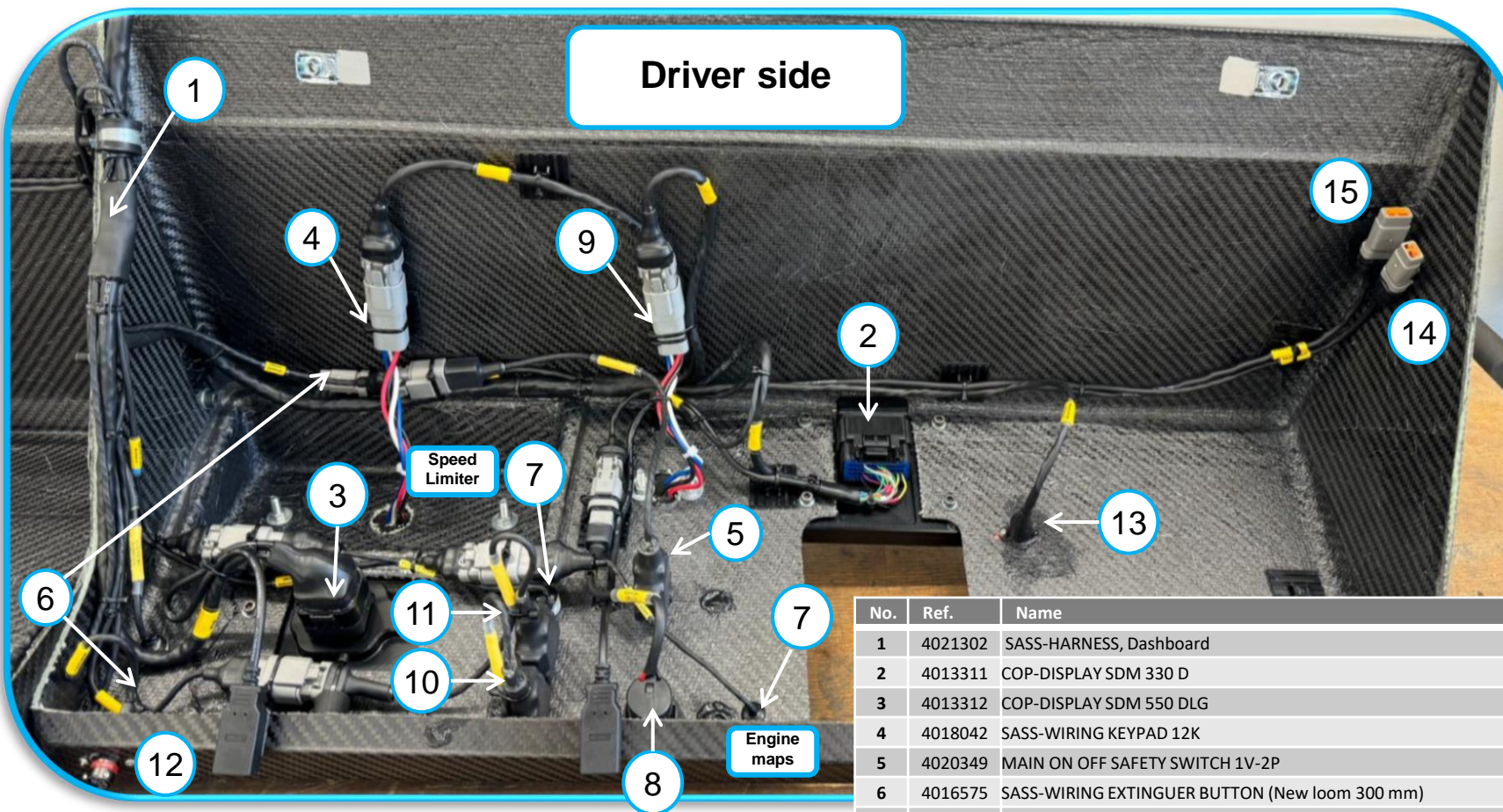

No.	Ref.	Name	Qty.
1	4021302	SASS-HARNESS, Dashboard	
2	4013311	COP-DISPLAY SDM 330 D	1
3	4013312	COP-DISPLAY SDM 550 DLG	1
4	4018042	SASS-WIRING KEYPAD 12K	1
5	4020349	MAIN ON OFF SAFETY SWITCH 1V-2P	1
6	4016575	SASS-WIRING EXTINGUER BUTTON (New loom 300 mm)	1
7	4019937	SASS-WIRING MAP OR SPEED LIMITOR ROTACTOR	2
8	4017463	SASS-WIRING USB	1
9	4020997	SASS-WIRING KEYPAD 4K	1
10	4020412	SPEED LIMITER ON OFF	1
11	4020411	SPEED LIMIT ADJUSTER +/-	1
12	-	CAN CONNECTOR	1
13	-	STEERING WHEEL CONNECTOR	1
14	-	LEFT FIRE EXTINGUISHER CONNECTOR	1
15	-	LEFT SAFETY SWITCH CONNECTOR	1

# 17.9.5 ELECTRICAL COMPONENTS – Dashboard – Loom set-up

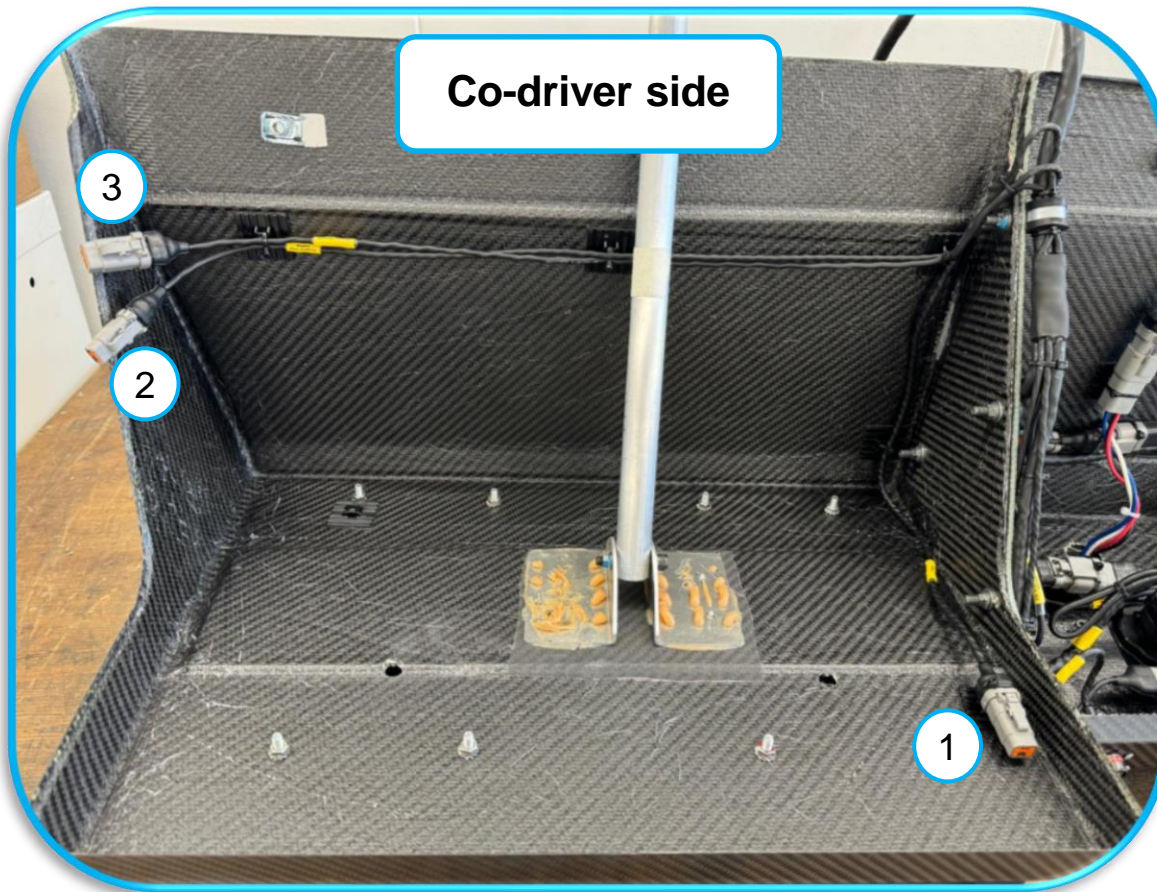

No.	Ref.	Name	Qty.
1	-	CAN CONNECTOR FOR CUSTOMER	1
2	-	LEFT FIRE EXTINGUISHER CONNECTOR	1
3	-	LEFT SAFETY SWITCH CONNECTOR	1

# 17.10 ELECTRICAL COMPONENTS – Vehicle Lighting

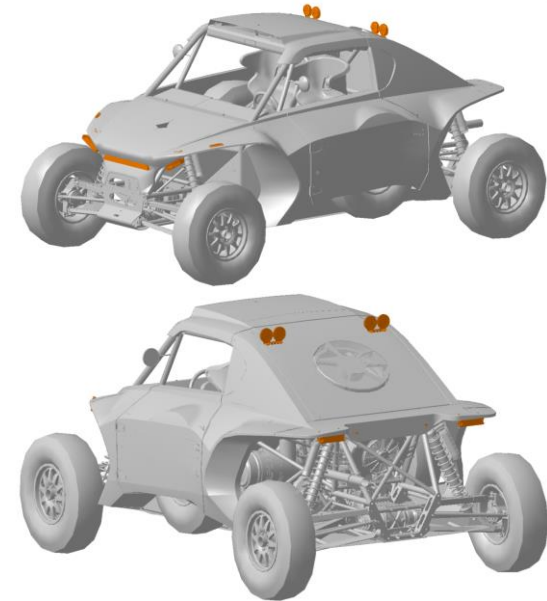
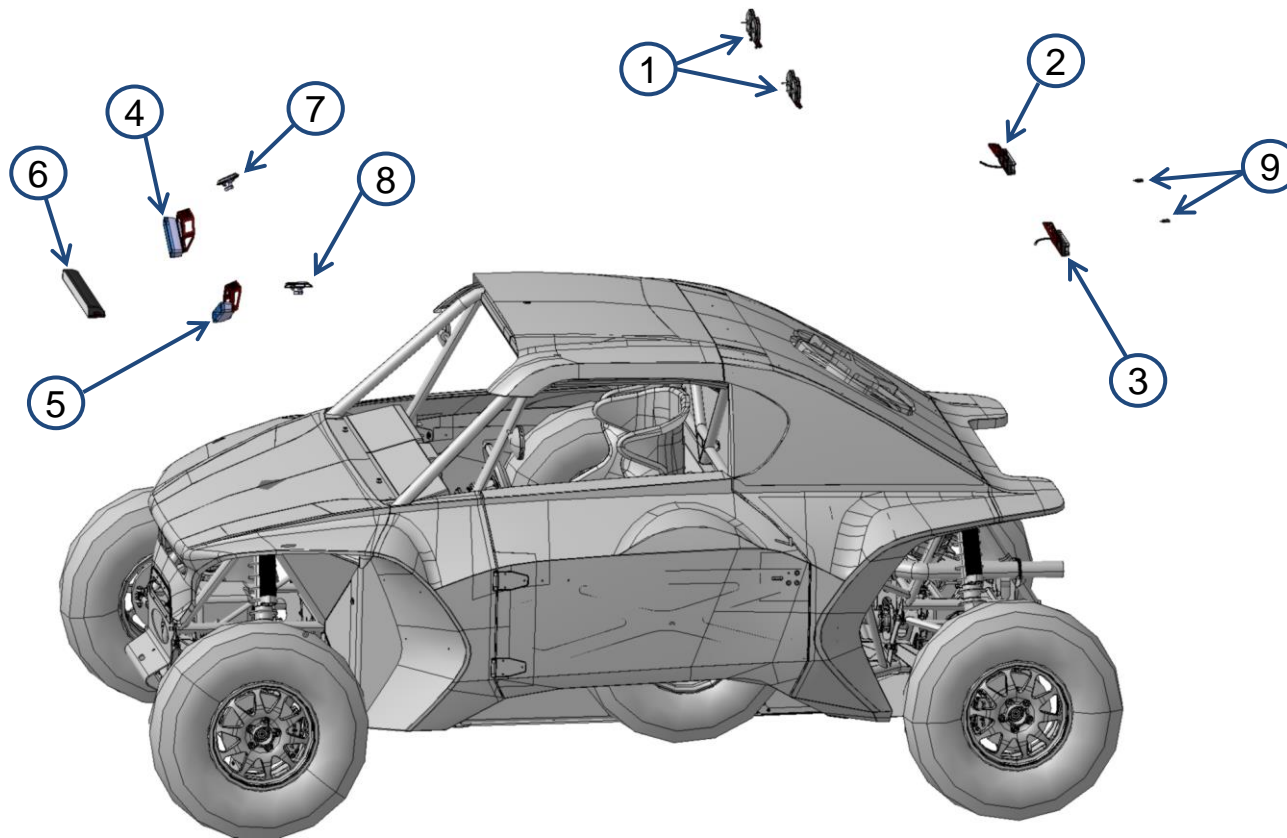

No.	Ref.	Name	Qty.
1	4014544	SASS-REAR TOP LIGHTS	2
2	4014545	SASS-RIGHT REAR LOW LIGHTS	1
3	4014546	SASS-LEFT REAR LOW LIGHTS	1
4	4015020	SASS-RIGHT FRONT LIGHTS	1
5	4015021	SASS-LEFT FRONT LIGHTS	1
6	4015206	SASS-LED BAR LAZER LINEAR 18 ELITE	1
7	4015014	SASS-FRONT FLASH LIGTHS RIGHT	1
8	4015013	SASS-FRONT FLASH LIGTHS LEFT	1
9	4017407	SASS-WIRING LICENCE PLATE LIGHT	1



# 17.10.1 ELECTRICAL COMPONENTS – Vehicle Lighting – Front Lights Right & Left

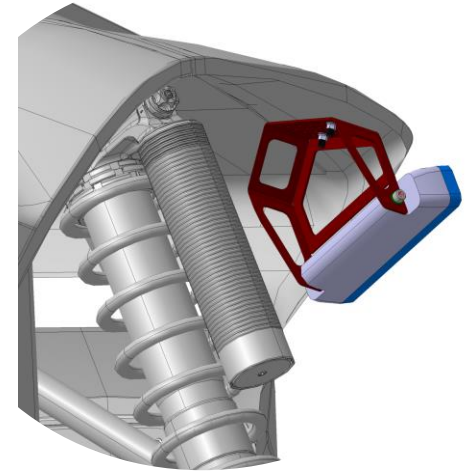
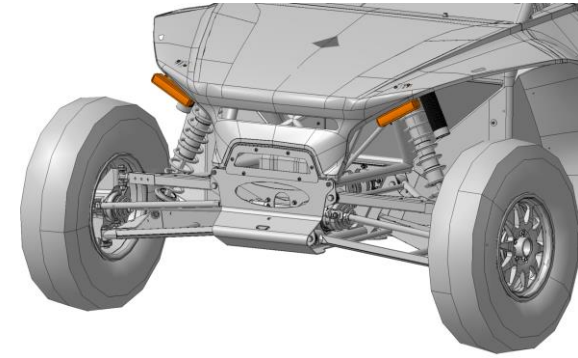
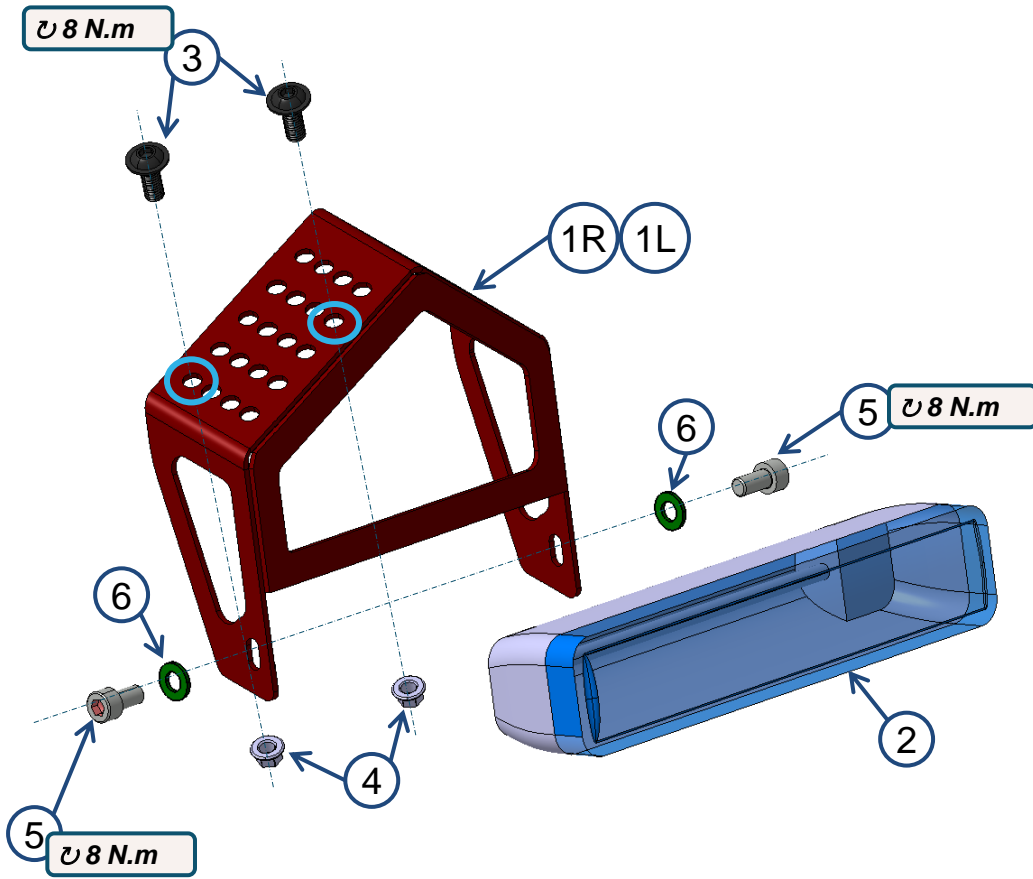

No.	Ref.	Name	Qty.
1 R	4014947	DRP-COMPONENT FRONT LIGHT SUPPORT RIGHT	1
1 L	4014946	DRP-COMPONENT FRONT LIGHT SUPPORT LEFT	1
2	4016606	SASS-WIRING FRONT LIGHT L/R	1
3	4013534	COP-SCREW BUTTON HEAD WITH FLANGE - M6X16 P100 - CL10.9 – BLACK	2
4	4013685	SUP-LOCKNUT WITH FLANGE - M6X1.00 – SIMMONDS	2
5	4000932	SUP-HEXAGONAL SOCKET CAP SCREW ISO 4762 M6X12-12 P100 CL12.9 A B	2
6	4009150	SUP-PLAIN WASHER D6XD12X1.2 TYPE Z NFE25-514 A EZ	2

# 17.10.2 ELECTRICAL COMPONENTS – Vehicle Lighting – Led Bar Lazer Linear

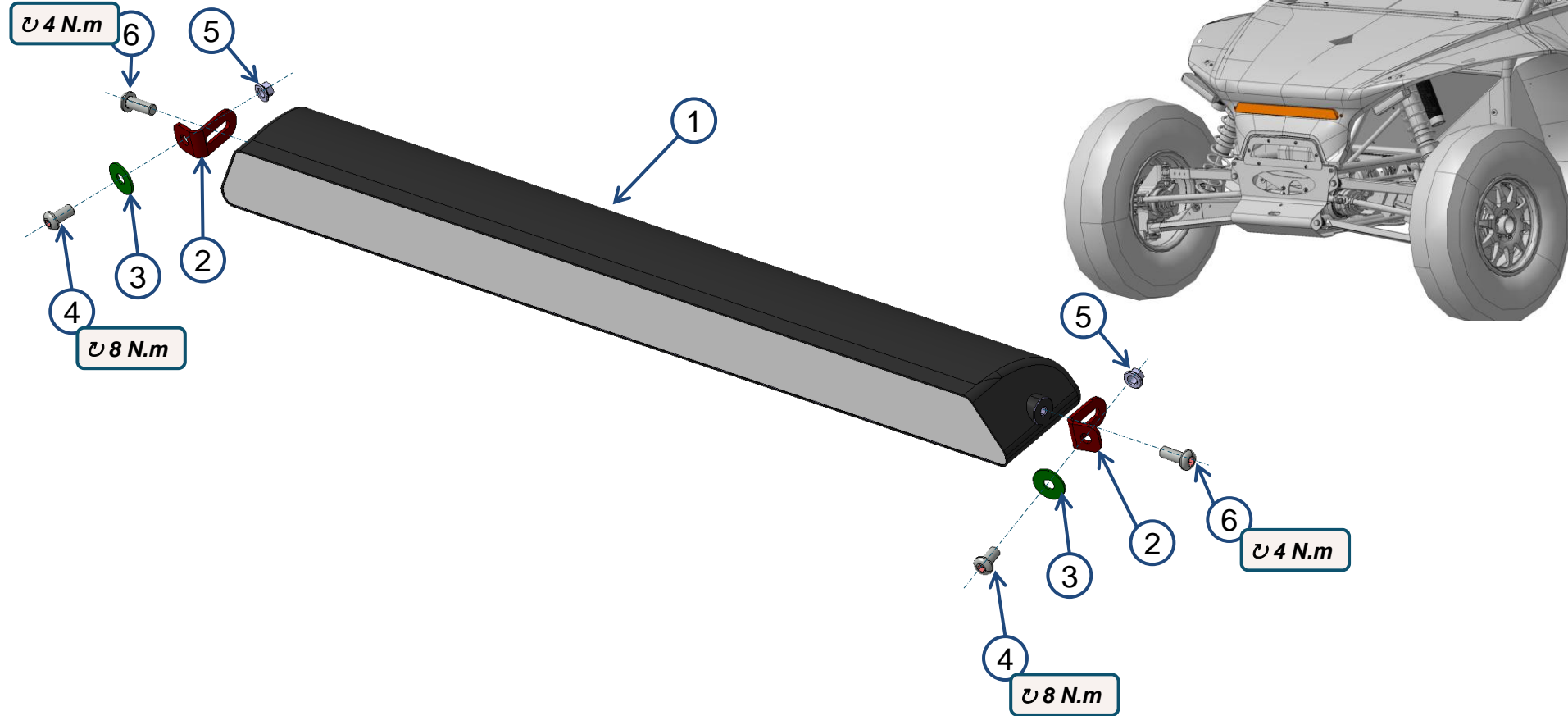

No.	Ref.	Name	Qty.
1	4016608	SASS-HARNESS RAMPE LED FRONT LIGHT WIRING	1
2	4015207	DRP-COMPONENT BRACKET LED BAR LAZER LINEAR 18 ELITE	2
3	4009189	SUP-PLAIN WASHER D6XD18X1.2 TYPE L NFE25-514 A EZ	2
4	4018191	SUP-BUTTON HEAD SCREW ISO 7380 M6X12-12 P100 CL10.9 A B	2
5	4013685	SUP-LOCKNUT WITH FLANGE - M6X1.00 – SIMMONDS	2
6	4008192	SUP-BUTTON HEAD SCREW ISO 7380 M6X16-16 P100 CL10.9 A B	2

# 17.10.3 ELECTRICAL COMPONENTS – Vehicle Lighting – Front Flash Lights

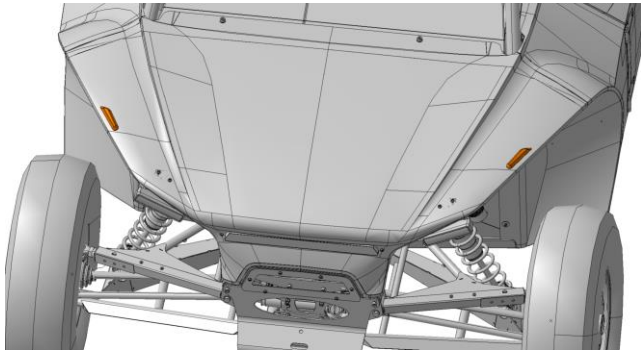
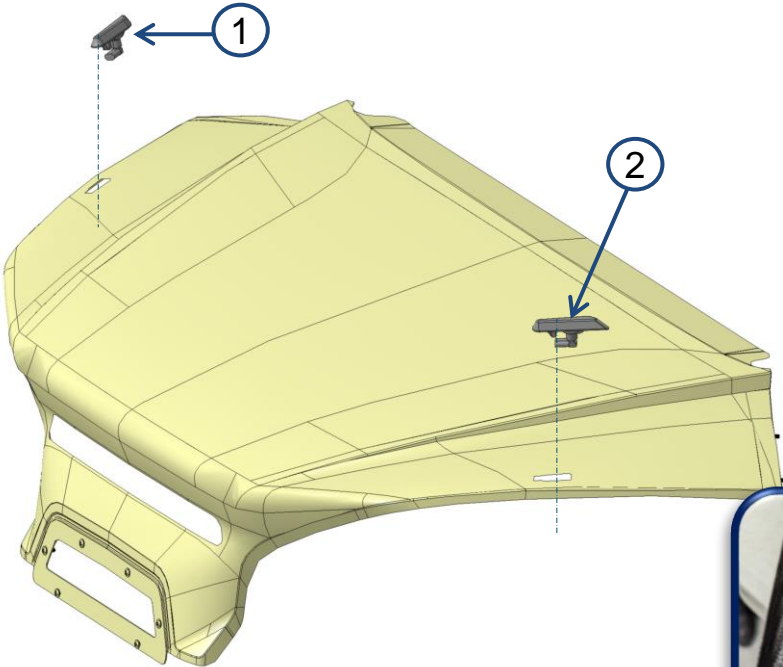

Inside Hood View

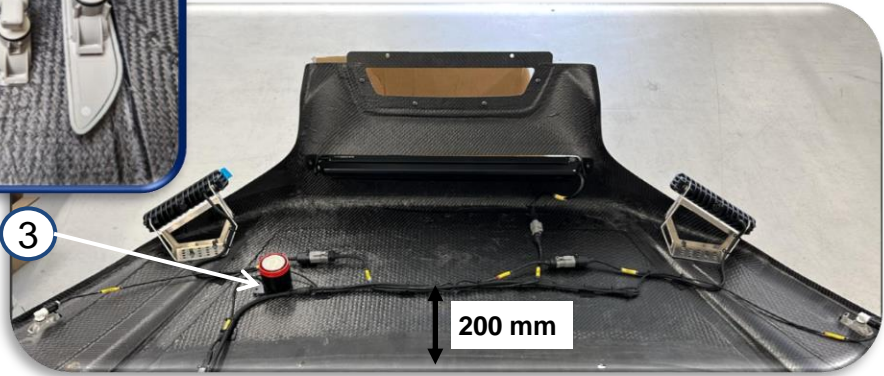
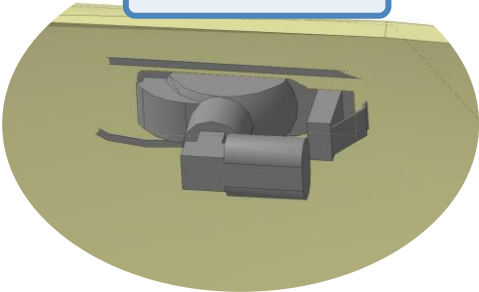

No.	Ref.	Name	Qty.
1	4015014	COP-RIGHT FLASHING LIGHTS	1
2	4015013	COP-LEFT FLASHING LIGHTS	1
3	4016547	WIRED HORN	1

# 17.9.5 ELECTRICAL COMPONENTS – Vehicle Lighting – Rear top Lights

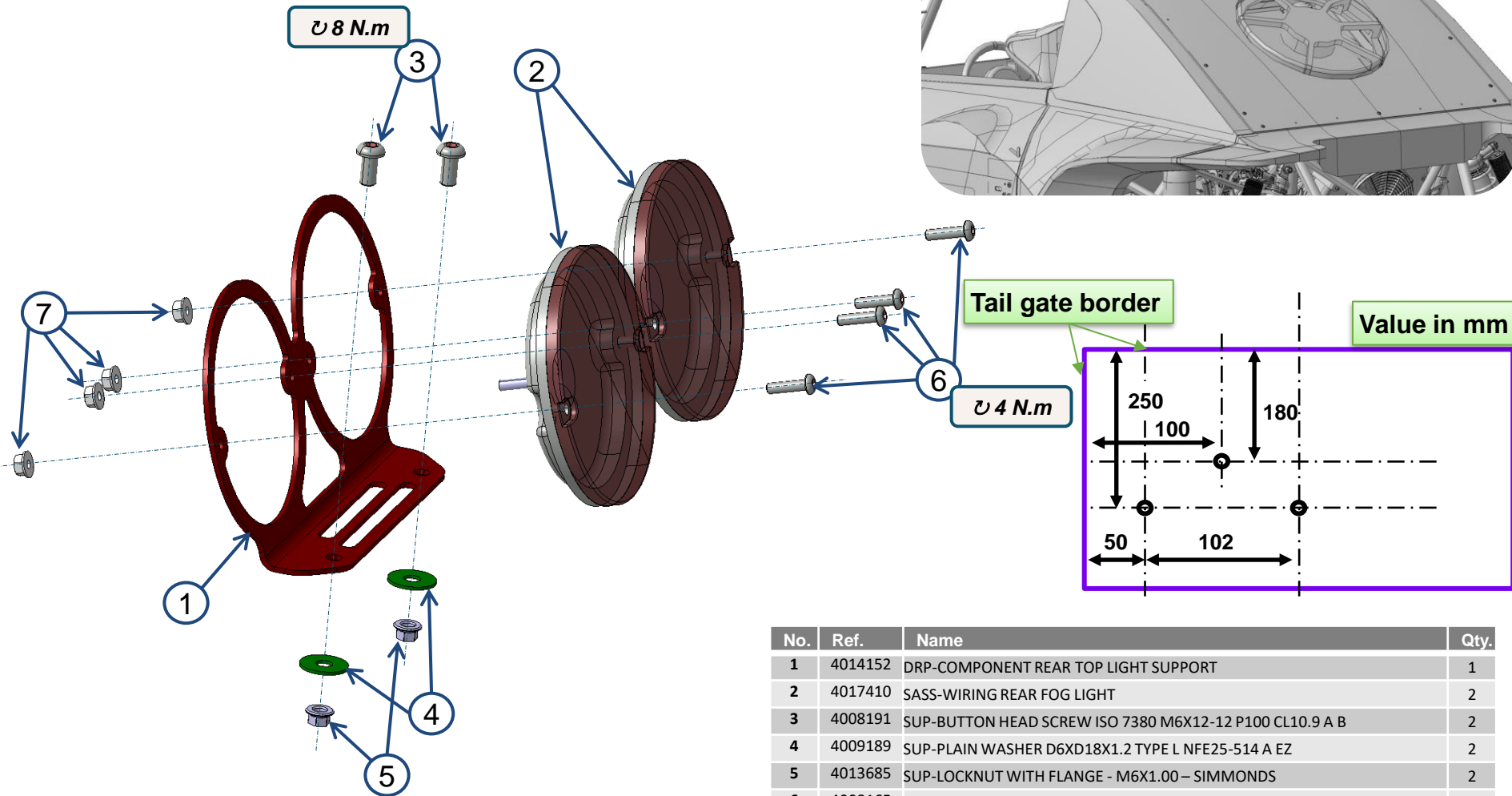
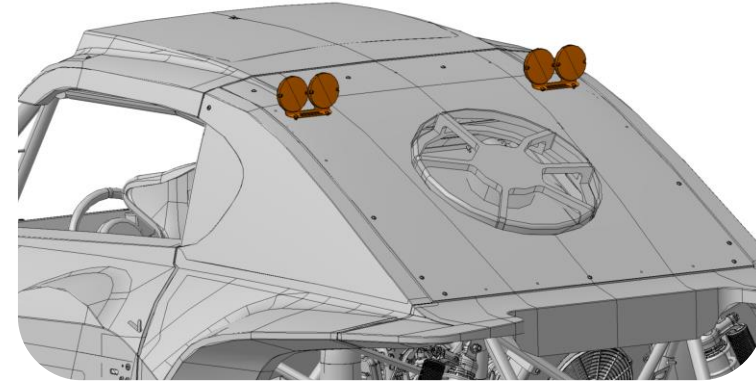

No.	Ref.	Name	Qty.
1	4014152	DRP-COMPONENT REAR TOP LIGHT SUPPORT	1
2	4017410	SASS-WIRING REAR FOG LIGHT	2
3	4008191	SUP-BUTTON HEAD SCREW ISO 7380 M6X12-12 P100 CL10.9 A B	2
4	4009189	SUP-PLAIN WASHER D6XD18X1.2 TYPE L NFE25-514 A EZ	2
5	4013685	SUP-LOCKNUT WITH FLANGE - M6X1.00 – SIMMONDS	2
6	4008165	SUP-BUTTON HEAD SCREW ISO 7380 M4X16-16 P70 CL10.9 A B	4
7	4009012	SUP-FLANGE NUT M4X4.5 P70 CL10 ISO4161 A B	4

# 17.10.4 ELECTRICAL COMPONENTS – Vehicle Lighting – Rear Low Lights Right & Left

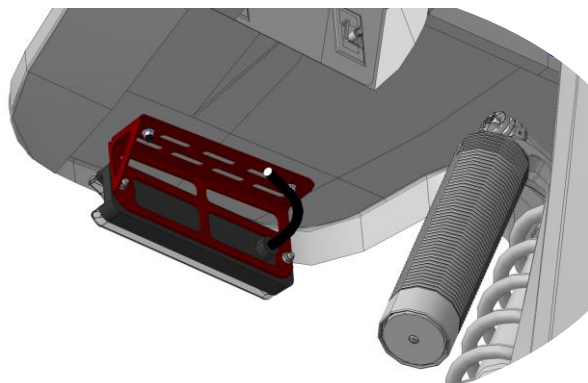
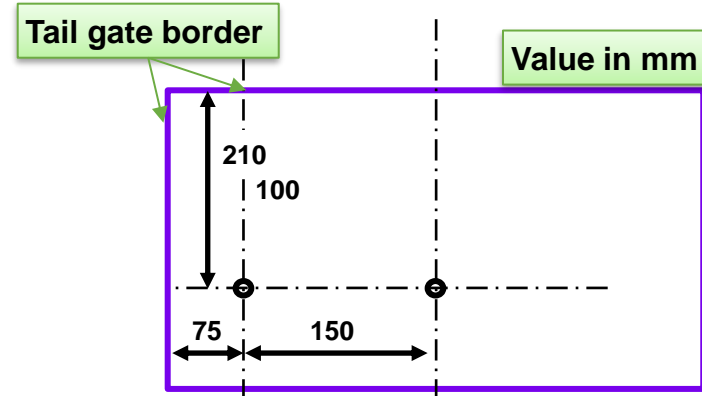
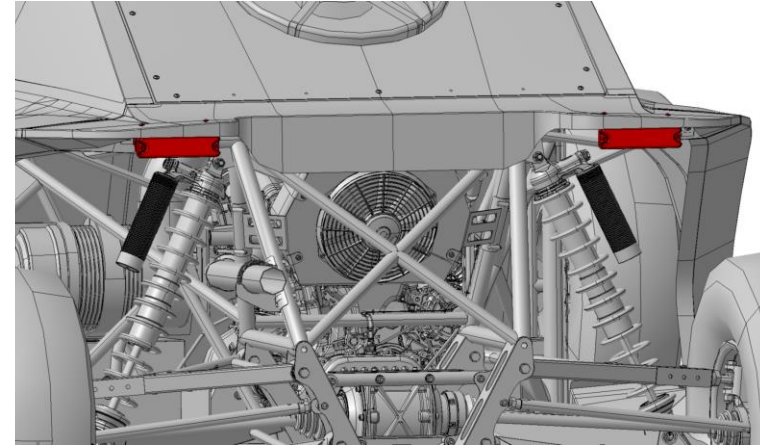
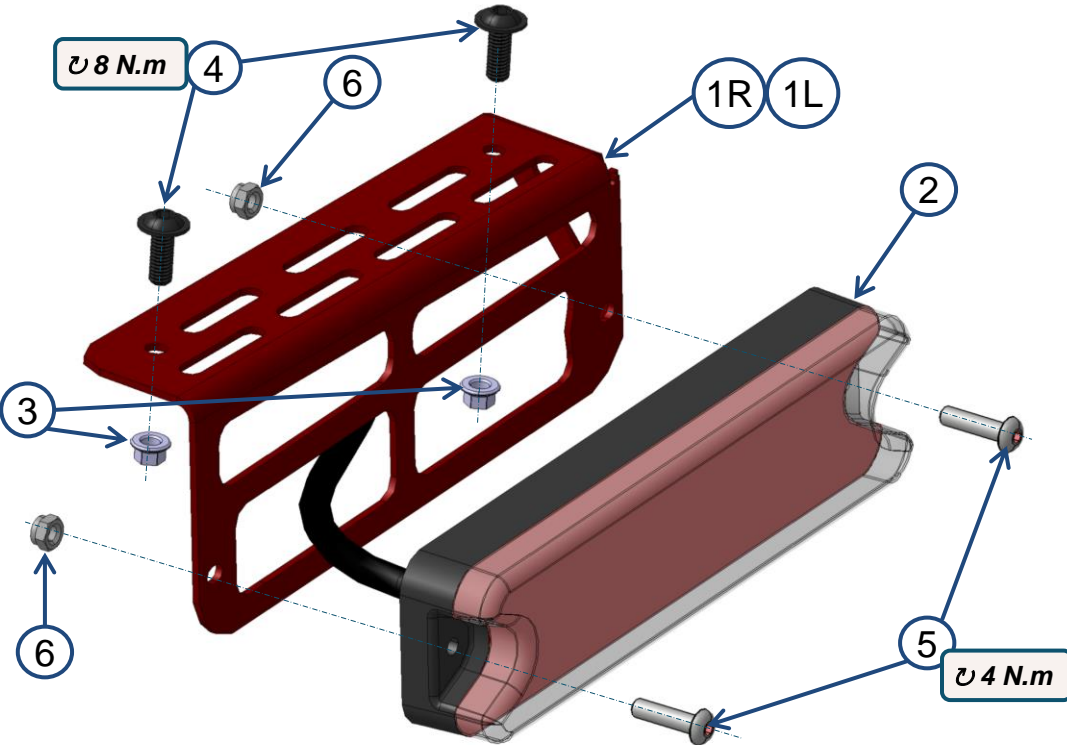

No.	Ref.	Name	Qty.
1 R	4014154	DRP-COMPONENT REAR LOW RIGHT LIGHT SUPPORT	1
1 L	4014156	DRP-COMPONENT REAR LOW LEFT LIGHT SUPPORT	1
2	4017594	SASS-WIRING REAR LIGHT L/R	1
3	4013685	SUP-LOCKNUT WITH FLANGE - M6X1.00 – SIMMONDS	2
4	4013534	COP-SCREW BUTTON HEAD WITH FLANGE - M6X16 P100 - CL10.9 – BLACK	2
5	4008179	SUP-BUTTON HEAD SCREW ISO 7380 M5X20-20 P80 CL10.9 A B	2
6	4016944	SUP-LOCKNUT WITH FLANGE - M5X0.8 - SIMMONDS	2

# 17.10.5 ELECTRICAL COMPONENTS – Vehicle Lighting – Pack Led Immat

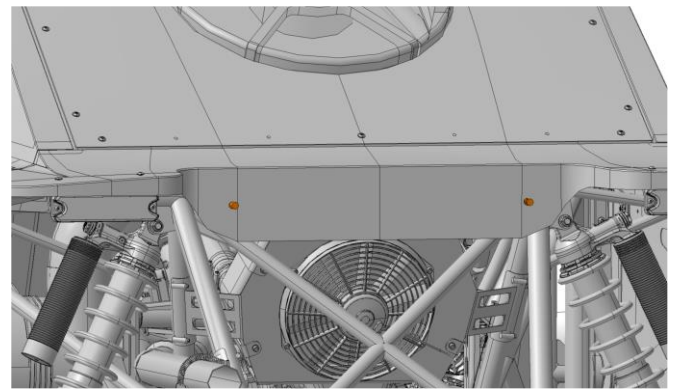
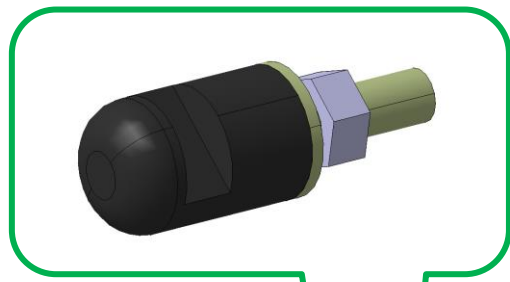

Position lights according to dimensions bellow

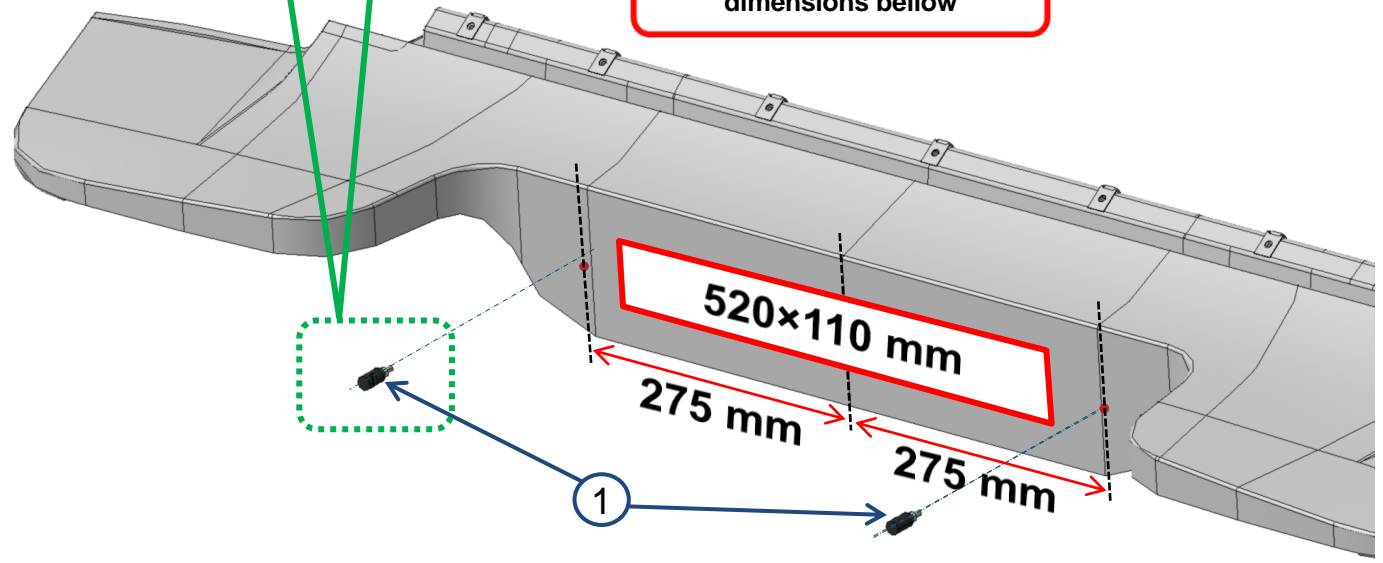

No.	Ref.	Name	Qty.
1	4017407	WIRED LICENSE PLATE	2

# 17.10.6 ELECTRICAL COMPONENTS – Vehicle Lighting – Rear loom light set-up

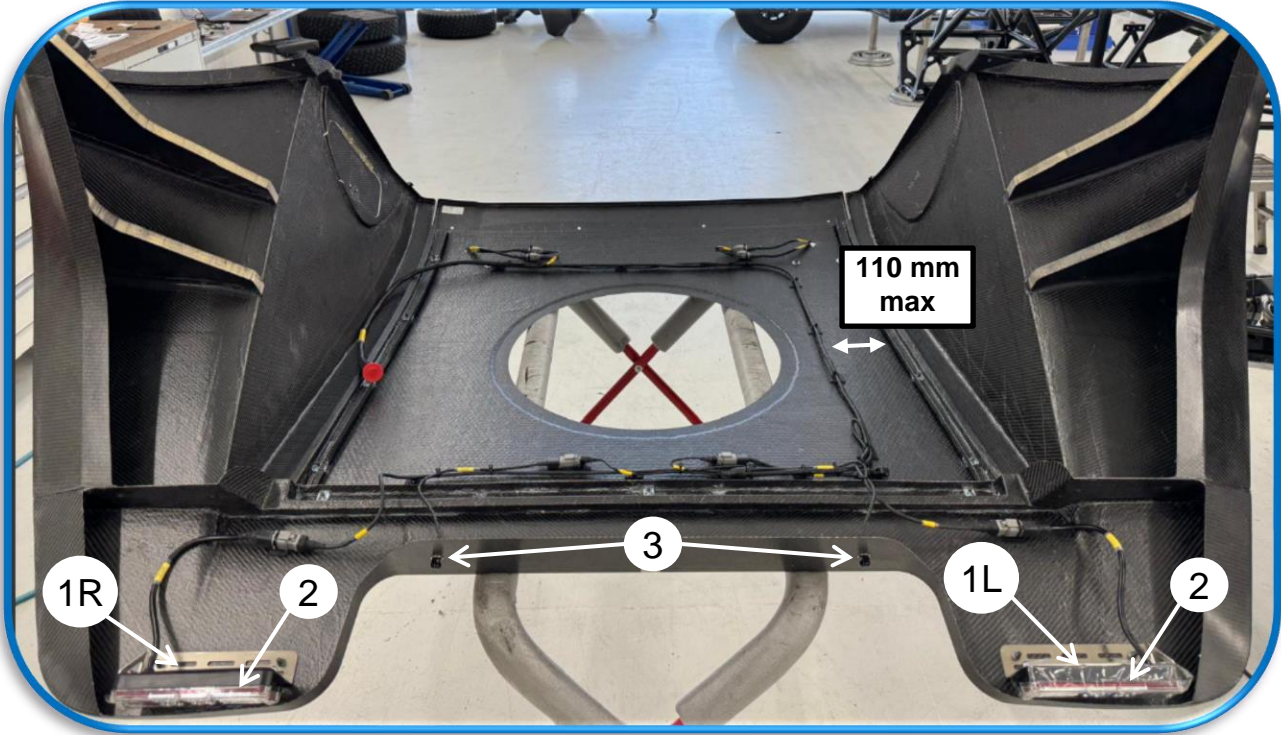

No.	Ref.	Name	Qty.
0	4018929	SASS HARNESS Rear Lights	1
1 R	4014154	DRP-COMPONENT REAR LOW RIGHT LIGHT SUPPORT	1
1 L	4014156	DRP-COMPONENT REAR LOW LEFT LIGHT SUPPORT	1
2	4017594	SASS-WIRING REAR LIGHT L/R	1
3	4017407	WIRED LICENSE PLATE	1

# 17.11 ELECTRICAL COMPONENTS – Navigation System – Marlink

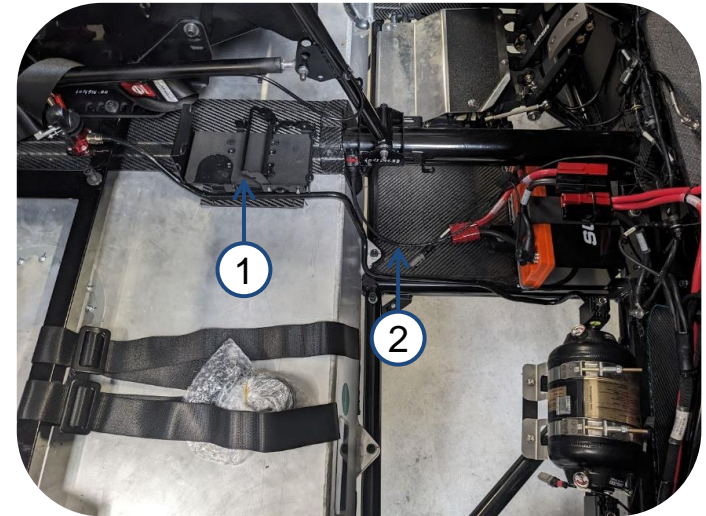
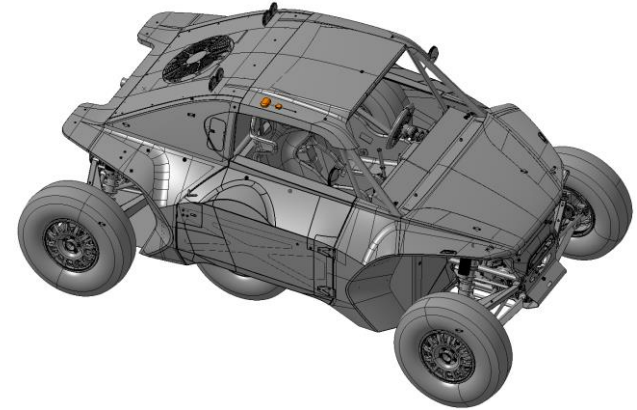
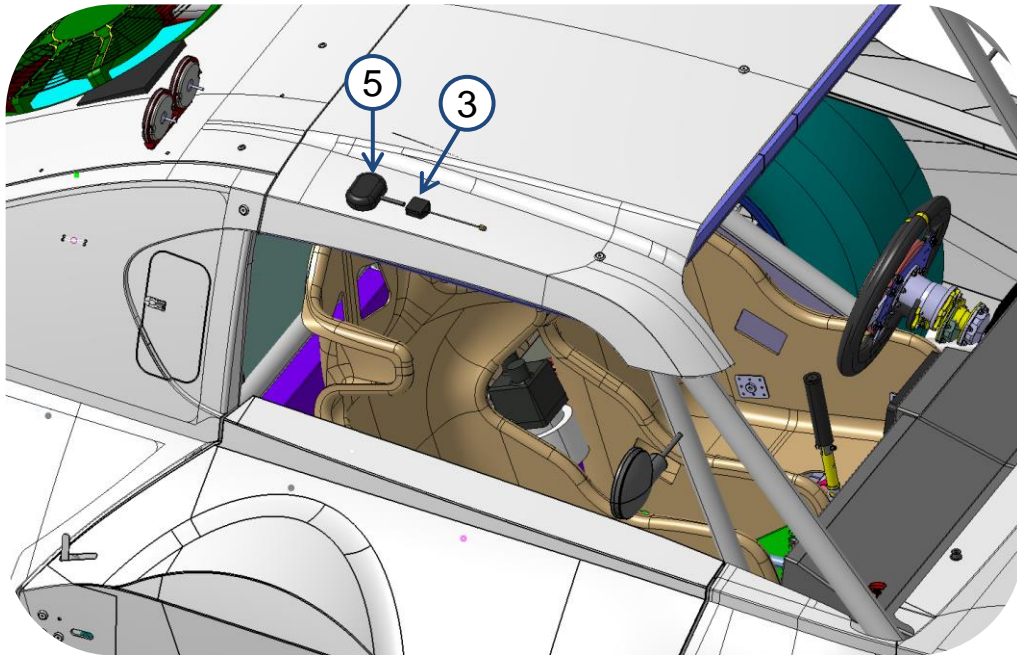

Position antennas according to drilling templates

No.	Ref.	Name	Qty.
1	4013302	COP-TO BE DEFINED SUPPORT IRITRACK V3	1
2	4018443	COP-TO BE DEFINED IRITRACK POWER CABLE	1
3	4018442	COP-TO BE DEFINED MARLINK GPS ANTENNA	1
4	4018444	COP-TO BE DEFINED GPS ANTENNA CABLE	1
5	4018441	COP-TO BE DEFINED IRIDIUM ANTENNA	1



# 17.12 ELECTRICAL COMPONENTS – Navigation System – Ertf Unik IV

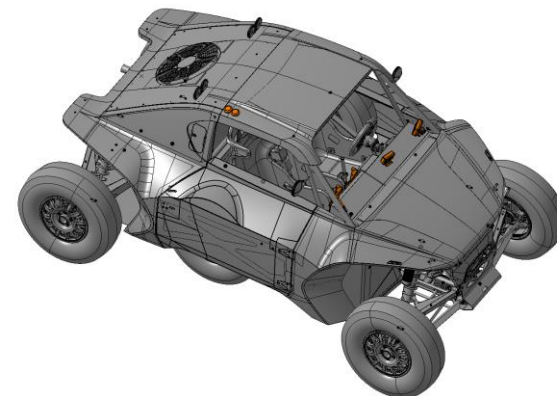
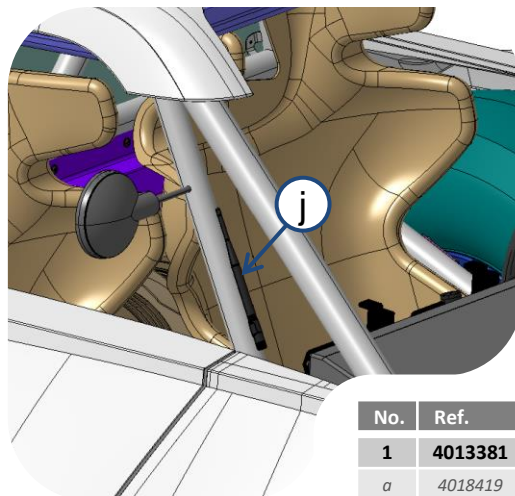
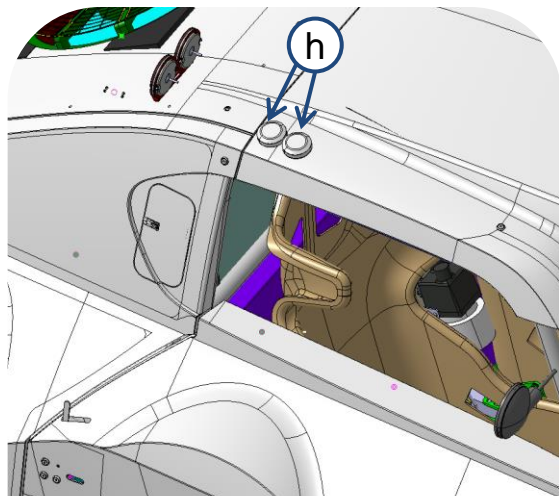

**Position antennas according to drilling templates**

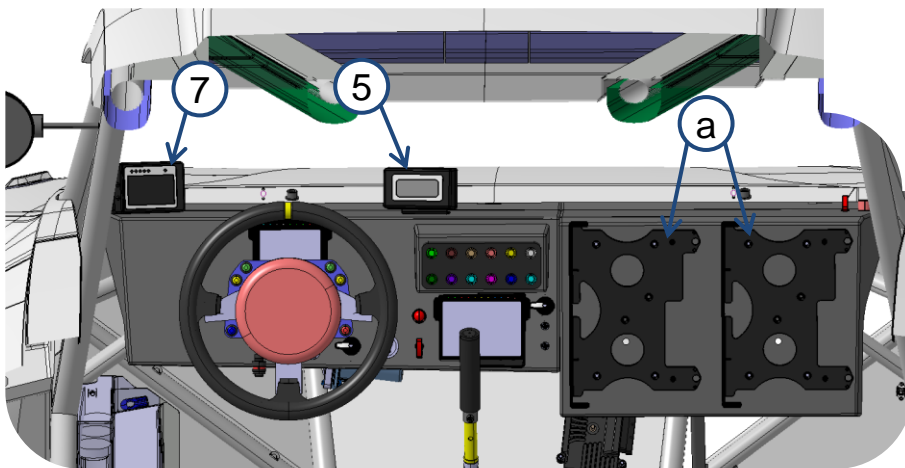

**Remote (f), red (c) and yellow (d) button should be in the cockpit and available for the copilot to hold**

No.	Ref.	Name	Qty.
<b>1</b>	<b>4013381</b>	<b>COP-KIT COMPLETE UNIK IV ↓</b>	<b>1</b>
a	4018419	COP-TO BE DEFINED SUPPORT UNIK	1
b	4018448	COP-TO BE DEFINED ALIMENTATION CABLE UNIK	1
c	4018449	COP-TO BE DEFINED YELLOW BUTTON UNIK	1
d	4018450	COP-TO BE DEFINED RED BUTTON UNIK	1
e	4018451	COP-TO BE DEFINED REMOTE CABLE UNIK	1
f	4018452	COP-TO BE DEFINED REMOTE UNIK	1
g	4018453	COP-TO BE DEFINED BUZZER UNIK	1
h	4018454	COP-TO BE DEFINED GPS ANTENNA UNIK	1
i	4018455	COP-TO BE DEFINED GPS ANTENNA CABLE UNIK	1
j	4018456	COP-TO BE DEFINED SENTINEL ANTENNA UNIK	1
<b>2</b>	<b>4013934</b>	<b>COP-KIT INSTALLATION GPS UNIK4 SUPPLÉMENTAIRE ↓</b>	<b>1</b>
a	4018419	COP-TO BE DEFINED SUPPORT UNIK	1
b	4018448	COP-TO BE DEFINED ALIMENTATION CABLE UNIK	1
h	4018454	COP-TO BE DEFINED GPS ANTENNA UNIK	1
i	4018455	COP-TO BE DEFINED GPS ANTENNA CABLE UNIK	1
<b>3</b>	<b>4013383</b>	<b>COP-WIRING CONNECTION</b>	<b>1</b>
<b>4</b>	<b>4013385</b>	<b>COP-WIRING CONNECTION GPS</b>	<b>1</b>
<b>5</b>	<b>4018472</b>	<b>COP-TO BE DEFINED HEADING REPEATER FOR GPS + SUPPORT</b>	<b>1</b>
<b>6</b>	<b>4013384</b>	<b>COP-WIRING FOR RS232 GPS SIGNAL</b>	<b>1</b>
<b>7</b>	<b>4018471</b>	<b>COP-TO BE DEFINED SPEEDOCAP V4 EVO + SUPPORT</b>	<b>1</b>
<b>8</b>	<b>4013382</b>	<b>COP-WIRING ADAPTER FOR ODOMETER RESET</b>	<b>1</b>

## Section 18

### WHEELS

# 18 WHEELS – Overview

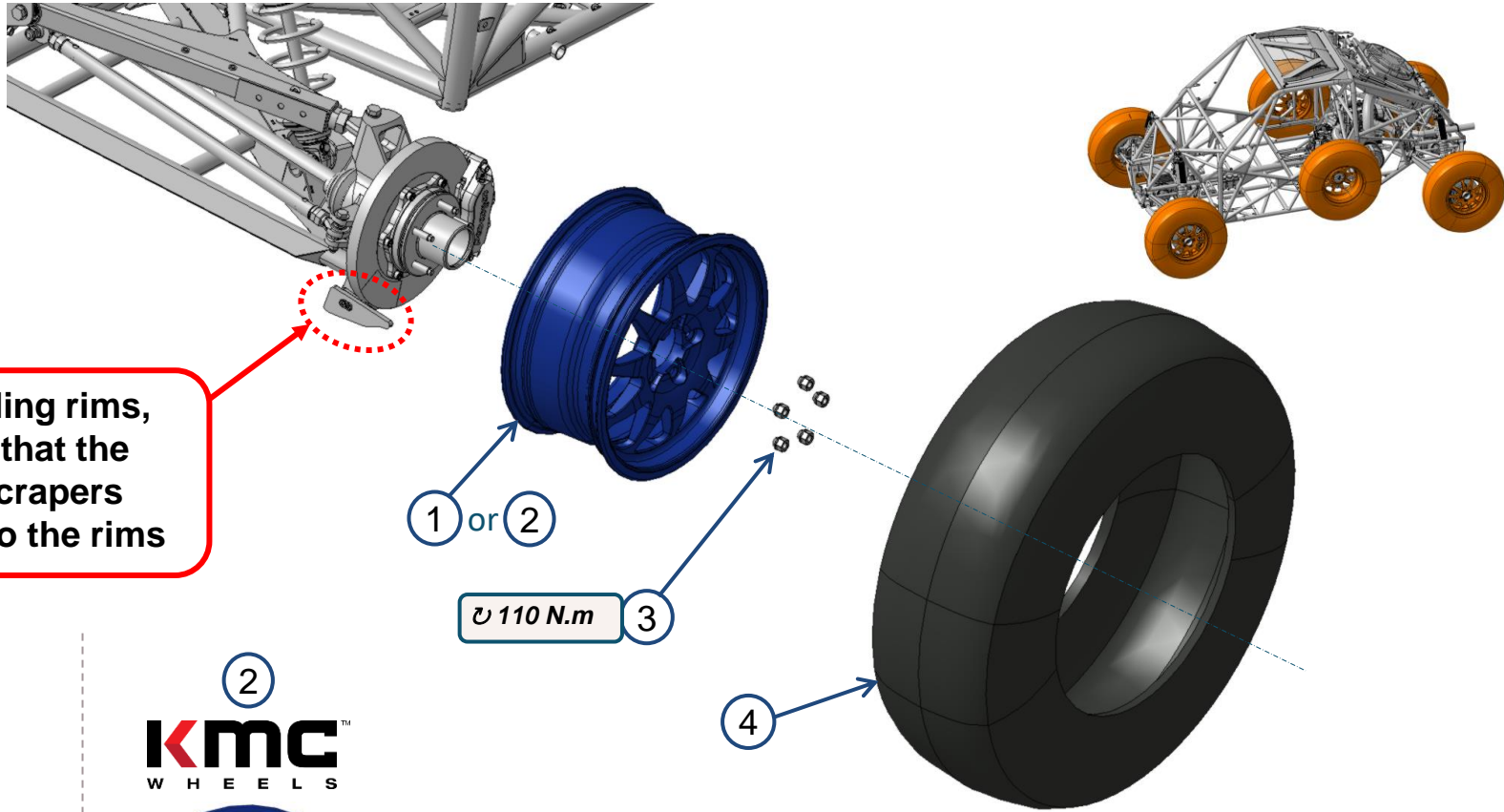

When installing rims, make sure that the installed scrapers correspond to the rims

110 N.m



No.	Ref.	Name	Qty.
1	4013109	WHEEL RIM - BRAID FR TA 7J15 ET50	1
2	4014783	KMC RIM - 15" - REDBULL	1
3	4020597	WHEEL RIM – BEADLOCK A FORGED 15" – BRAID ET50	1
4	4012432	NUT WHEEL M12 P125 CONICAL 60°	1
5	4013110	TIRE - BFG 32X9.5X15 KDR3 SXS	1
6	4021836	TIRE - TENSOR 32 x10 15" WHITE	

## Section 19

### TOOLS

# 19.1 Tooling Jack Stand

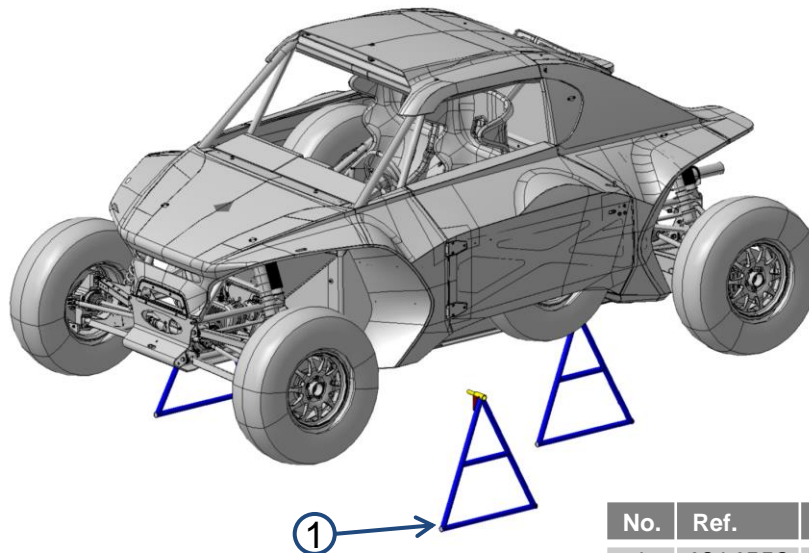
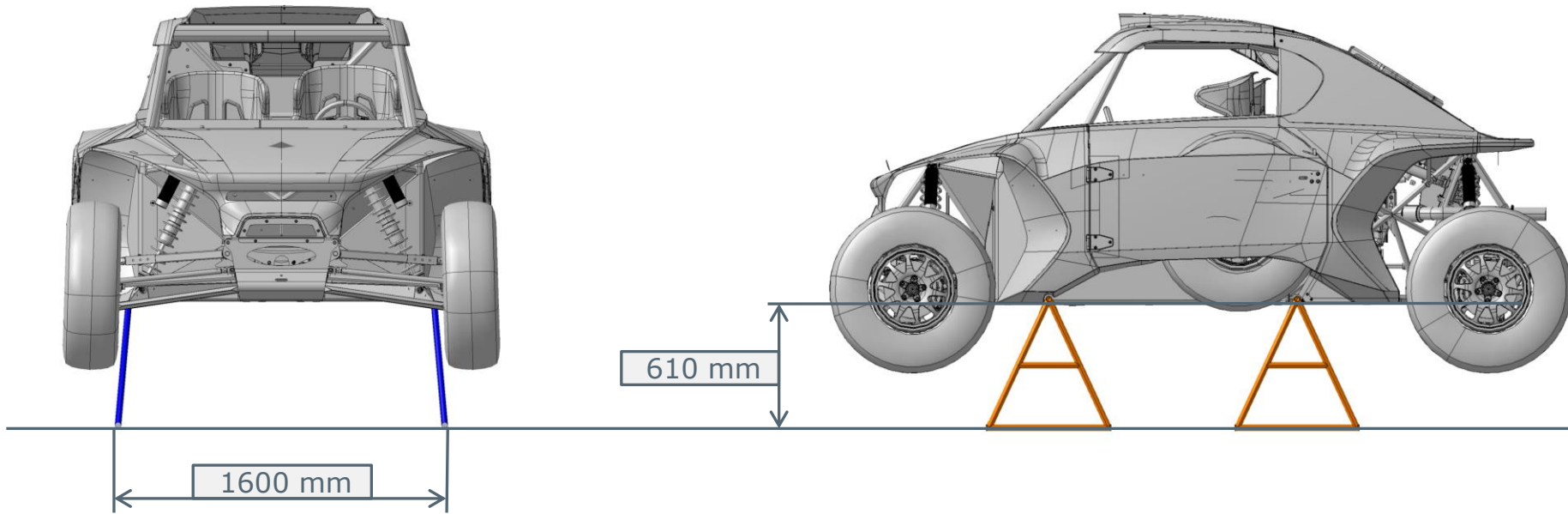

No.	Ref.	Name	Qty.
1	4014553	COMPONENT JACK STAND	4

## 19.2 Tooling Jack Bracket and position



No.	Ref.	Name	Qty.
1			1
2			1

## 19.3 Tooling NutGun Bracket and position



No.	Ref.	Name	Qty.
1	4000003	Impact nutgun bracket	1
2	4000004	Key direction nutgun	1
3		Rivet	2
4		Bolt	2
5		Washer	2
6		Nut	2

## 20.3 CAPACITIES



	OIL QUANTITY
ENGINE	5L
GEARBOX	1,2L
DIFFERENTIALS	0,9L

	GREASE QUANTITY
DIFF side	80gr
HUB side	120gr
LOBRO	60gr

	DIVERS
COOLANT FLUID	14L
BRAKE FLUIDS	1,5L



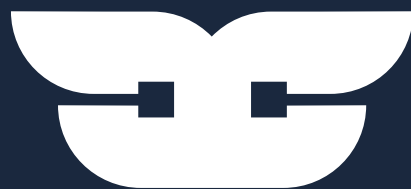

**TAURUS**